

CONSTRUCTION DETAIL			CONSTRUCTION DETAIL (CONTINUED)		
Element	Cd	Description	Element	Cd	Description
Style	55	Condominium			
Model	05	Res Condo			
Bedrm Func	C	Average			
Stories	1	1 Story			
Occupancy	0				
Interior Wall 1	05	Drywall			
Interior Wall 2					
Interior Floor 1	20	Typical			
Interior Floor 2					
Heat Fuel	04	Electric			
Heat Type	07	Elec Baseboard			
AC Type	01	None			
Bedrooms	02	2 Bedrooms			
Full Baths	2	2 Full			
Half Baths	0				
Extra Fixtures					
Total Rooms	4	4 Rooms			
Bath Style					
Kitchen Style					
Master Deed L	694				
Bath Split	20	2 Full-0 Half			
Foundation	09	Blk/Pour Ftgs			
AC Type Alt					
Sewer Occupan					
CONDO DATA					
Parcel Id	104239	C 0242	Owne	10.	
	SUNI SANDS		B 1	S 1	
Adjust Type	Code	Description	Factor%		
Condo Flr			100		
Condo Unit	MKT0	MKT0	100		
COST / MARKET VALUATION					
Building Value New			480,062		
Year Built			1950		
Effective Year Built			1989		
Depreciation Code			A		
Remodel Rating					
Year Remodeled					
Depreciation %			23		
Functional Obsol			0		
External Obsol			0		
Trend Factor			1		
Condition					
Condition %					
Percent Good			77		
Cns Sect Rcnd			369,600		
Dep % Ovr					
Dep Ovr Comment					
Misc Imp Ovr					
Misc Imp Ovr Comment					
Cost to Cure Ovr					
Cost to Cure Ovr Comment					

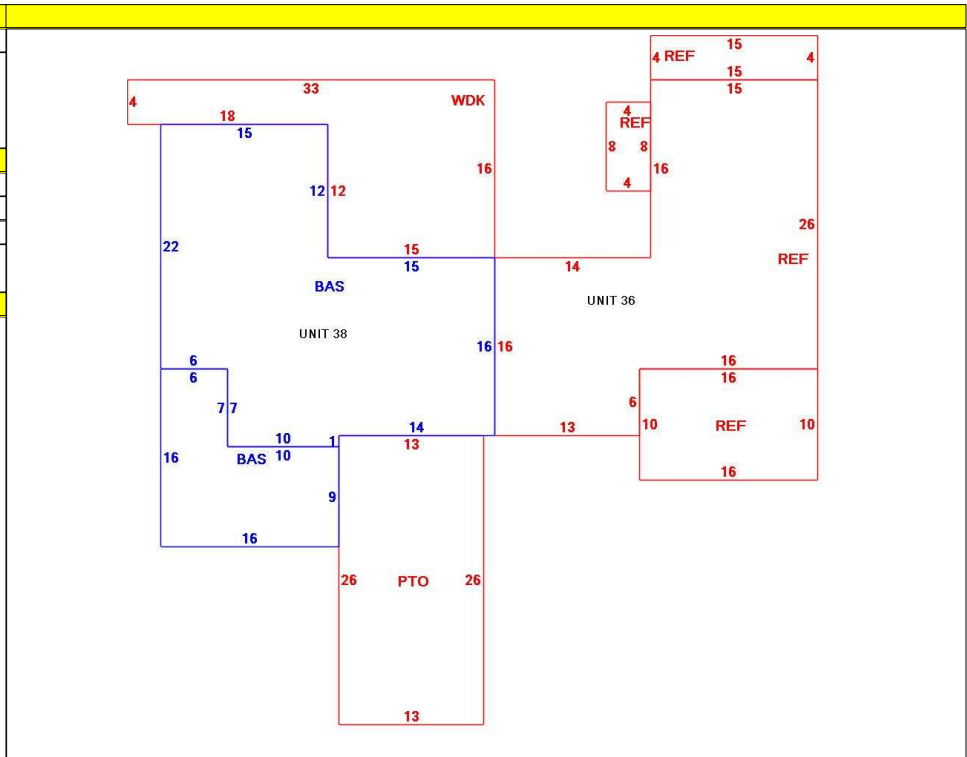

OB - OUTBUILDING & YARD ITEMS(L) / XF - BUILDING EXTRA FEATURES(B)

Code	Description	L/B	Units	Unit Price	Yr Blt	Cond. Cd	% Gd	Grade	Grade Adj.	Appr. Value
FPL1	Fireplace 1 sto	B	1	5000.00	1990		77		0.00	3,900
WDC	Wood Decking	L	312	20.00	2002		66		0.00	4,100
PAT2	Patio-Good	L	338	9.94	2002		83		0.00	2,800

BUILDING SUB-AREA SUMMARY SECTION

Code	Description	Living Area	Floor Area	Eff Area	Unit Cost	Undeprec Value
BAS	First Floor	820	820	820	585.44	480,062
PTO	Patio	0	338	0	0.00	0
REF	Reference Only	0	860	0	0.00	0
WDK	Wood Deck	0	312	0	0.00	0
Ttl Gross Liv / Lease Area		820	2,330	820		480,062

