

CURRENT OWNER		TOPO	UTILITIES	STRT / ROAD	LOCATION	CURRENT ASSESSMENT				
ISENSTADT, SUZANNE A TR S A ISENSTADT TRUST 3333 NE 32ND AVE APT 1106 FORT LAUDERD FL 33308						Description	Code	Assessed	Assessed	801 FY2024 BARNSTABLE, MA
						RESIDNTL	1010	447,500	447,500	
						RES LAND	1010	205,300	205,300	VISION
SUPPLEMENTAL DATA						Total				
Alt Prcl ID Split Zonin BID Parcel ResExpt Q #DL 1 LOT 18 #DL 2 GIS ID F_975733_2695277				Plan Ref. Land Ct# 8993-C (SH 1) #SR Life Estate PP STATU Assoc Pid#				652,800		

RECORD OF OWNERSHIP		BK-VOL/PAGE	SALE DATE	Q/U	V/I	SALE PRIC	VC	PREVIOUS ASSESSMENTS (HISTORY)									
ISENSTADT, SUZANNE A TR		C203859	0	07-07-2014	U	I	10	1A	Year	Code	Assessed	Year	Code	Assessed	Year	Code	Assessed
ISENSTADT, ALAN TR		C55075	0	01-23-1995	U	I	0	1A	2023	1010	395,900	2022	1010	335,200	2021	1010	283,000
HERMAN, BERNARD TR		C55074	0	06-14-1972	U		0			1010	186,700		1010	128,400		1010	130,400
																1010	5,200
									Total		582,600	Total		463,600	Total		418,600

EXEMPTIONS				OTHER ASSESSMENTS				This signature acknowledges a visit by a Data Collector or Assessor										
Year	Code	Description	Amount	Code	Description	Number	Amount	Comm Int										
			Total				0.00											

ASSESSING NEIGHBORHOOD				APPRAISED VALUE SUMMARY													
Nbhd	Nbhd Name	B		Tracing		Batch											
0107						CENVIL											
NOTES														Appraised Bldg. Value (Card)		407,700	
														Appraised Xf (B) Value (Bldg)		34,600	
														Appraised Ob (B) Value (Bldg)		5,200	
														Appraised Land Value (Bldg)		205,300	
														Special Land Value		0	
														Total Appraised Parcel Value		652,800	
														Valuation Method		C	
														Total Appraised Parcel Value		652,800	

BUILDING PERMIT RECORD									VISIT / CHANGE HISTORY						
Permit Id	Issue Date	Type	Description	Amount	Insp Date	% Comp	Date Comp	Comments	Date	Id	Type	Is	Cd	Purpost/Result	
200802928	07-15-2008	WD	Wood Deck	5,000	10-07-2008	100	06-30-2009	16X40	05-18-2020	WD			FR	Field Review	
200706568	10-30-2007	RE	Remodel	25,000	10-07-2008	100	06-30-2009	KIT. & 3 BATHS	05-18-2017	SR	02		14	Cyclical Inspection	
									08-28-2014	JR	03		16	In Office Review	
									06-22-2011	DR	22		22	Change of Address	
									11-23-2009	PT	04		44	Drive by inspection only	
									06-18-2009	NF	03		16	In Office Review	
									04-23-2009	JR	03		16	In Office Review	

LAND LINE VALUATION SECTION																	
B	Use Code	Description	Zone	LA	Land Units	Unit Price	Size Adj	AC Disc	Site Index	Cond.	Nbhd.	Nbhd. Adj	Notes	Location Adjustmen	Adj Unit P	Land Value	
1	1010	Single Fam M-0	CBD	3	0.230	AC	176,344.00	3.61599	1.0000	5	1.00	0107	1.400		1.0000	892,723.8	205,300
Total Card Land Units					0.23	AC	Parcel Total Land Area					0.23	Total Land Value			205,300	

CONSTRUCTION DETAIL			CONSTRUCTION DETAIL (CONTINUED)		
Element	Cd	Description	Element	Cd	Description
Style	04	Cape Cod			
Model	01	Residential			
Grade:	C	Average			
Stories	1.75	1 3/4 Stories			
Exterior Wall 1	14	Wood Shingle			
Exterior Wall 2					
RooF Structure	03	Gable/Hip			
RooF Cover	03	Asph/F Gls/Cmp			
Interior Wall 1	05	Drywall			
Interior Wall 2					
Interior Floor 1	14	Carpet			
Interior Floor 2					
Heat Fuel	03	Gas			
Heat Type	05	Hot Water			
AC Type	01	None			
Bedrooms	04	4 Bedrooms			
Full Baths	3				
Half Baths	0				
Extra Fixtures					
Total Rooms	6				
Bath Style					
Kitchen Style					
Occupancy					
Usrflid 105					
Accessory Apt					
Foundation Alt	01	Poured Conc.			
Rms Prts					
Bath Split	30	3 Full-0 Half			

CONDO DATA				
Parcel Id		C		Ownr 0.0
			B	S
Adjust Type	Code	Description	Factor%	
Condo Flr				
Condo Unit				

COST / MARKET VALUATION	
Building Value New	529,481
Year Built	1958
Effective Year Built	1990
Depreciation Code	G
Remodel Rating	
Year Remodeled	
Depreciation %	23
Functional Obsol	0
External Obsol	0
Trend Factor	1
Condition	
Condition %	
Percent Good	77
RCNLD	407,700
Dep % Ovr	
Dep Ovr Comment	
Misc Imp Ovr	
Misc Imp Ovr Comment	
Cost to Cure Ovr	
Cost to Cure Ovr Comment	

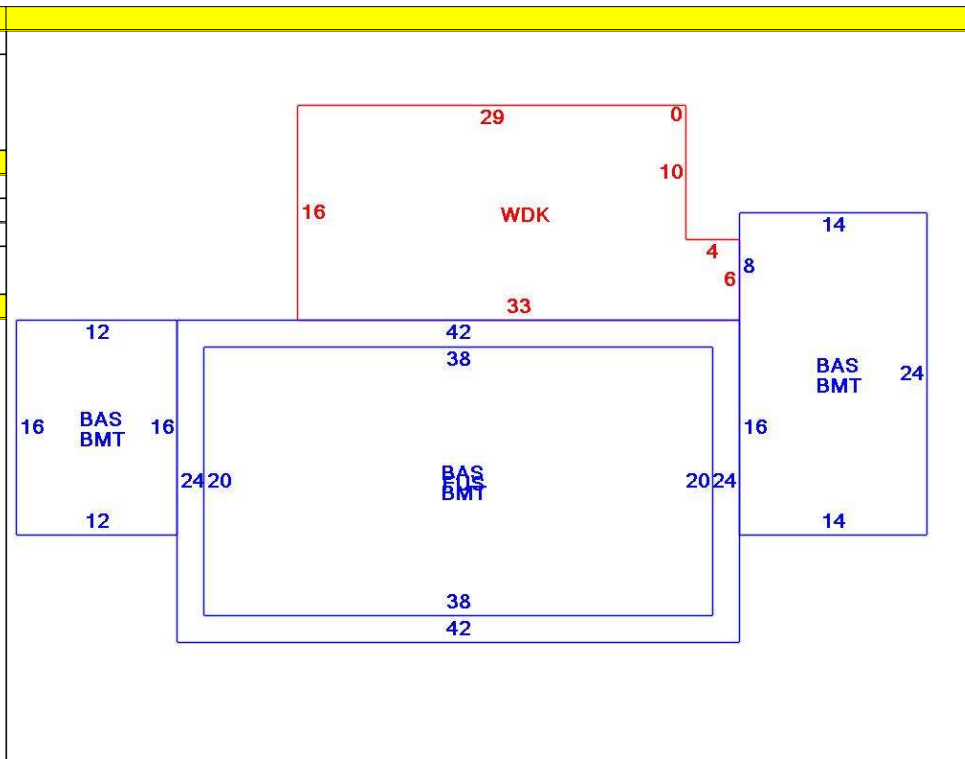

OB - OUTBUILDING & YARD ITEMS(L) / XF - BUILDING EXTRA FEATURES(B)										
Code	Description	L/B	Units	Unit Price	Yr Blt	Cond. Cd	% Gd	Grade	Grade Adj.	Appr. Value
FPL2	Fireplace 1.5 s	B	1	6000.00	1992		77		0.00	4,600
WDC	Wood Decking	L	488	20.00	1997		56		0.00	5,200
BGAR	Bsmt Garage	B	1	2326.00	1992		77		0.00	1,800
BMT	Basement-Unfi	B	1,568	26.01	1992		77		0.00	28,200

BUILDING SUB-AREA SUMMARY SECTION						
Code	Description	Living Area	Floor Area	Eff Area	Unit Cost	Undeprec Value
BAS	First Floor	1,536	1,536	1,536	230.61	354,217
BMT	Basement Area	0	1,536	0	0.00	0
FUS	Upper Story	760	760	760	230.61	175,264
WDK	Wood Deck	0	488	0	0.00	0
Ttl Gross Liv / Lease Area		2,296	4,320	2,296		529,481

