

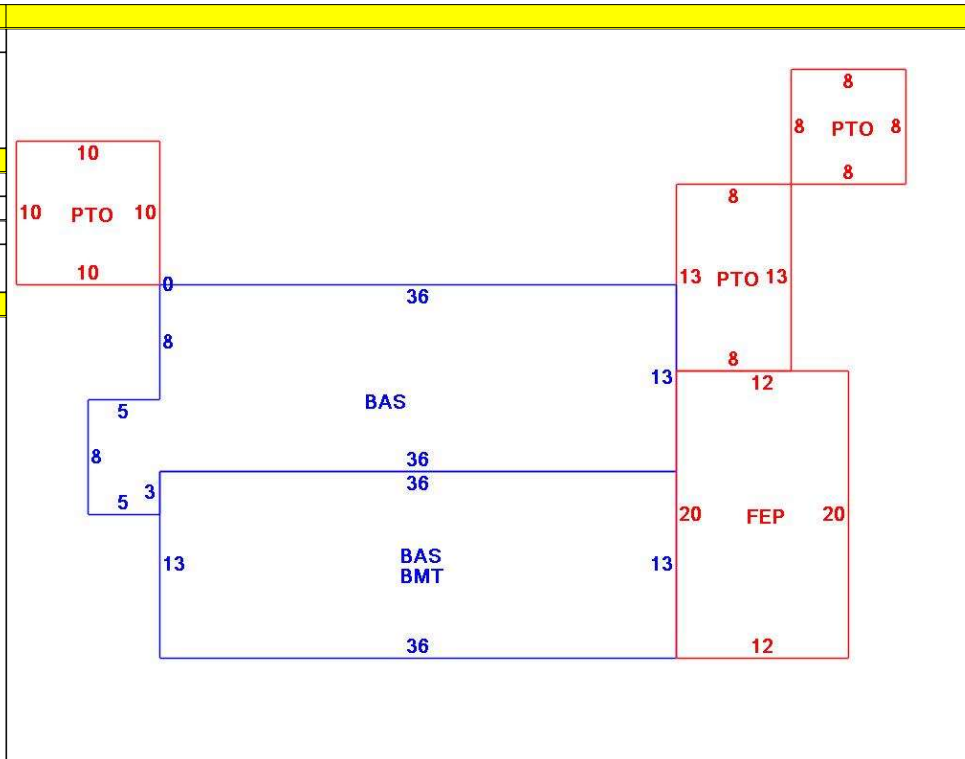

CONSTRUCTION DETAIL			CONSTRUCTION DETAIL (CONTINUED)		
Element	Cd	Description	Element	Cd	Description
Style	01	Ranch			
Model	01	Residential			
Grade:	C	Average			
Stories	1	1 Story			
Exterior Wall 1	14	Wood Shingle			
Exterior Wall 2					
Roof Structure	03	Gable/Hip			
Roof Cover	03	Asph/F Gls/Cmp			
Interior Wall 1	03	Plastered			
Interior Wall 2					
Interior Floor 1	14	Carpet			
Interior Floor 2					
Heat Fuel	03	Gas			
Heat Type	04	Hot Air			
AC Type	01	None			
Bedrooms	03	3 Bedrooms			
Full Baths	1				
Half Baths	0				
Extra Fixtures					
Total Rooms	5	5 Rooms			
Bath Style					
Kitchen Style					
Occupancy					
Usrflid 105					
Accessory Apt					
Foundation Alt	08	Mixed			
Rms Prts					
Bath Split	10	1 Full-0 Half			

CONDO DATA			
Parcel Id		C	Ownr 0.0
Adjust Type	Code	Description	Factor%
Condo Flr			
Condo Unit			

COST / MARKET VALUATION		
Building Value New		287,383
Year Built		1950
Effective Year Built		1981
Depreciation Code		A
Remodel Rating		
Year Remodeled		
Depreciation %		30
Functional Obsol		0
External Obsol		0
Trend Factor		1
Condition		
Condition %		
Percent Good		70
RCNLD		201,200
Dep % Ovr		
Dep Ovr Comment		
Misc Imp Ovr		
Misc Imp Ovr Comment		
Cost to Cure Ovr		
Cost to Cure Ovr Comment		



OB - OUTBUILDING & YARD ITEMS(L) / XF - BUILDING EXTRA FEATURES(B)										
Code	Description	L/B	Units	Unit Price	Yr Blt	Cond. Cd	% Gd	Grade	Grade Adj.	Appr. Value
FEP	Enclosed porc	B	240	70.00	1983		70		0.00	9,900
BMT	Basement-Unfi	B	468	26.01	1983		70		0.00	11,200
PAT1	Patio- Average	L	268	5.89	1992		46		0.00	700

BUILDING SUB-AREA SUMMARY SECTION						
Code	Description	Living Area	Floor Area	Eff Area	Unit Cost	Undeprec Value
BAS	First Floor	976	976	976	294.45	287,383
BMT	Basement Area	0	468	0	0.00	0
FEP	Enclosed Porch	0	240	0	0.00	0
PTO	Patio	0	268	0	0.00	0
Ttl Gross Liv / Lease Area		976	1,952	976		287,383

