

CURRENT OWNER		TOPO	UTILITIES	STRT / ROAD	LOCATION	CURRENT ASSESSMENT			
SILLER, JOANNE 301 FOREST GLEN WEST SPRINGF MA 01089		1 Level	2 Public Water	1 Paved		Description	Code	Assessed	Assessed
			4 Gas			RESIDNTL	1010	533,700	533,700
			6 Septic			RES LAND	1010	197,100	197,100
SUPPLEMENTAL DATA						Total			
Alt Prcl ID Split Zonin BID Parcel ResExpt Q #DL 1 LOT 37 #DL 2 GIS ID F_976238_2696826				Plan Ref. 76/1 Land Ct# #SR Life Estate PP STATU Assoc Pid#		730,800			

801
 FY2024
 BARNSTABLE, MA
VISION

RECORD OF OWNERSHIP		BK-VOL/PAGE	SALE DATE	Q/U	V/I	SALE PRIC	VC	PREVIOUS ASSESSMENTS (HISTORY)						
SILLER, JOANNE		24159	0074	11-12-2009	U	I	1	1A	Year	Code	Assessed	Year	Code	Assessed
SILLER, GERD & JOANNE		2899	0292	04-11-1979	U		0		2023	1010	451,200	2022	1010	363,800
										1010	179,200	2021	1010	125,100
													1010	7,000
									Total		630,400	Total		487,000
									Total		456,900	Total		456,900

EXEMPTIONS			OTHER ASSESSMENTS					
Year	Code	Description	Amount	Code	Description	Number	Amount	Comm Int
Total			0.00					

ASSESSING NEIGHBORHOOD			
Nbhd	Nbhd Name	B	Tracing
0107			CENVIL

NOTES			

BUILDING PERMIT RECORD								VISIT / CHANGE HISTORY						
Permit Id	Issue Date	Type	Description	Amount	Insp Date	% Comp	Date Comp	Comments	Date	Id	Type	Is	Cd	Purpost/Result
17-1288	05-03-2017	822	Insulation	4,400		100		Add 2" rigid insulation to the b	05-18-2020	WD			FR	Field Review
17-207	01-30-2017	822	Insulation	4,100		100		Weatherization, air sealing, we	02-08-2018	SR	02		03	Cycl Insp Comp
17-167	01-23-2017	822	Insulation	3,400		100		Weatherization	12-03-2009	PT	02		14	Cyclical Inspection
16-3460	11-29-2016	822	Insulation	7,500		100		Weatherization, air sealing, we	12-28-2001	PT	01		00	Meas/Listed-Interior Acces
41487	10-04-1999	RA	Remodel-Additi	61,000	04-19-2001	100	01-01-2001		04-19-2001	MF	02		02	Bldg Permit Completed
B27382	01-02-1985	AD	Addition	12,000	09-15-1986	100		HP 260SQF						
B27382A	01-01-1985	AD	Addition	12,000		100		HP 260SQF						

LAND LINE VALUATION SECTION																
B	Use Code	Description	Zone	LA	Land Units	Unit Price	Size Adj	AC Disc	Site Index	Cond.	Nbhd.	Nbhd. Adj	Notes	Location Adjustmen	Adj Unit P	Land Value
1	1010	Single Fam M-0	RB	3	0.180	AC	176,344.00	4.43465	1.0000	5	1.00	0107	1.400		1.0000	1,094,831
Total Card Land Units					0.18	AC	Parcel Total Land Area					0.18	Total Land Value			197,100

CONSTRUCTION DETAIL			CONSTRUCTION DETAIL (CONTINUED)		
Element	Cd	Description	Element	Cd	Description
Style	03	Colonial			
Model	01	Residential			
Grade:	C+	Average Plus			
Stories	2	2 Stories			
Exterior Wall 1	25	Vinyl Siding			
Exterior Wall 2					
RooF Structure	03	Gable/Hip			
RooF Cover	03	Asph/F Gls/Cmp			
Interior Wall 1	03	Plastered			
Interior Wall 2					
Interior Floor 1	09	Pine/Soft Wood			
Interior Floor 2					
Heat Fuel	03	Gas			
Heat Type	04	Hot Air			
AC Type	03	Central			
Bedrooms	04	4 Bedrooms			
Full Baths	2				
Half Baths	1				
Extra Fixtures					
Total Rooms	9	9 Rooms			
Bath Style					
Kitchen Style					
Occupancy					
UsrflD 105					
Accessory Apt					
Foundation Alt	09	Blk/Pour Ftgs			
Rms Prts					
Bath Split	21	2 Full-1 Half			

CONDO DATA				
Parcel Id		C		Ownr 0.0
Adjust Type	Code	Description	Factor%	
Condo Flr				
Condo Unit				

COST / MARKET VALUATION	
Building Value New	688,810
Year Built	1948
Effective Year Built	1985
Depreciation Code	G
Remodel Rating	
Year Remodeled	
Depreciation %	26
Functional Obsol	0
External Obsol	0
Trend Factor	1
Condition	
Condition %	
Percent Good	74
RCNLD	509,700
Dep % Ovr	
Dep Ovr Comment	
Misc Imp Ovr	
Misc Imp Ovr Comment	
Cost to Cure Ovr	
Cost to Cure Ovr Comment	

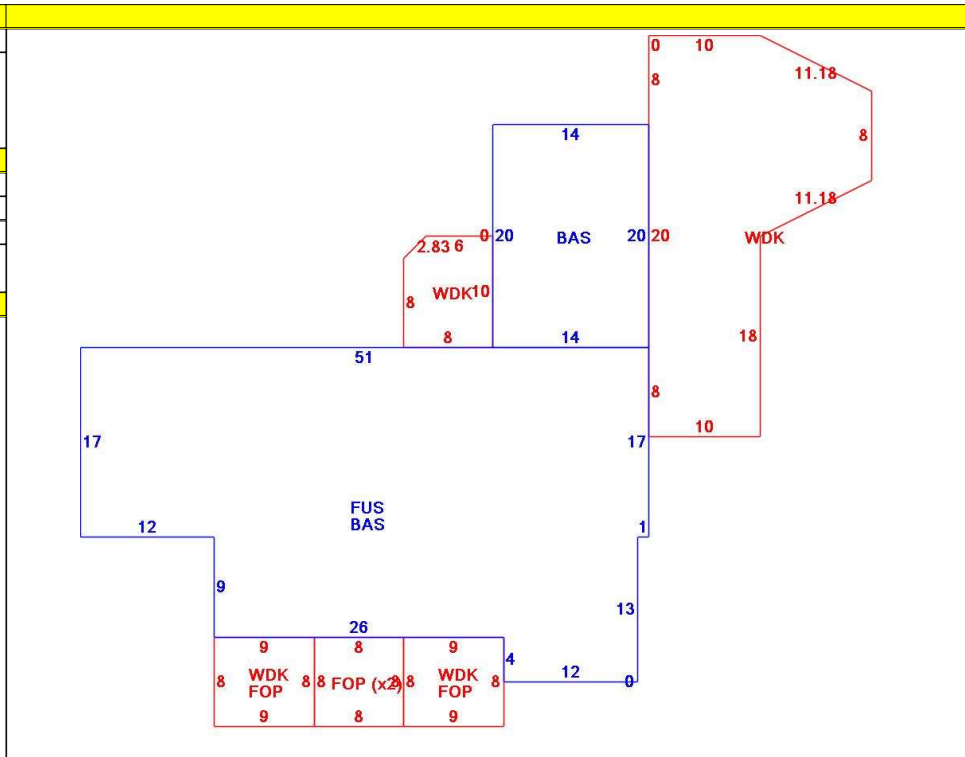

OB - OUTBUILDING & YARD ITEMS(L) / XF - BUILDING EXTRA FEATURES(B)										
Code	Description	L/B	Units	Unit Price	Yr Blt	Cond. Cd	% Gd	Grade	Grade Adj.	Appr. Value
FPL1	Fireplace 1 sto	B	1	5000.00	1987		74		0.00	3,700
WDC	Wood Decking	L	712	20.00	1996		54		0.00	7,000
FOP	Open Porch-ro	B	272	55.00	1987		74		0.00	8,100
FPL3	Fireplace 2 sto	B	1	7000.00	1987		74		0.00	5,200

BUILDING SUB-AREA SUMMARY SECTION						
Code	Description	Living Area	Floor Area	Eff Area	Unit Cost	Undeprec Value
BAS	First Floor	1,537	1,537	1,537	246.53	378,920
FOP	Open Porch	0	272	0	0.00	0
FUS	Upper Story	1,257	1,257	1,257	246.53	309,891
WDK	Wood Deck	0	712	0	0.00	0
Ttl Gross Liv / Lease Area		2,794	3,778	2,794		688,811

