

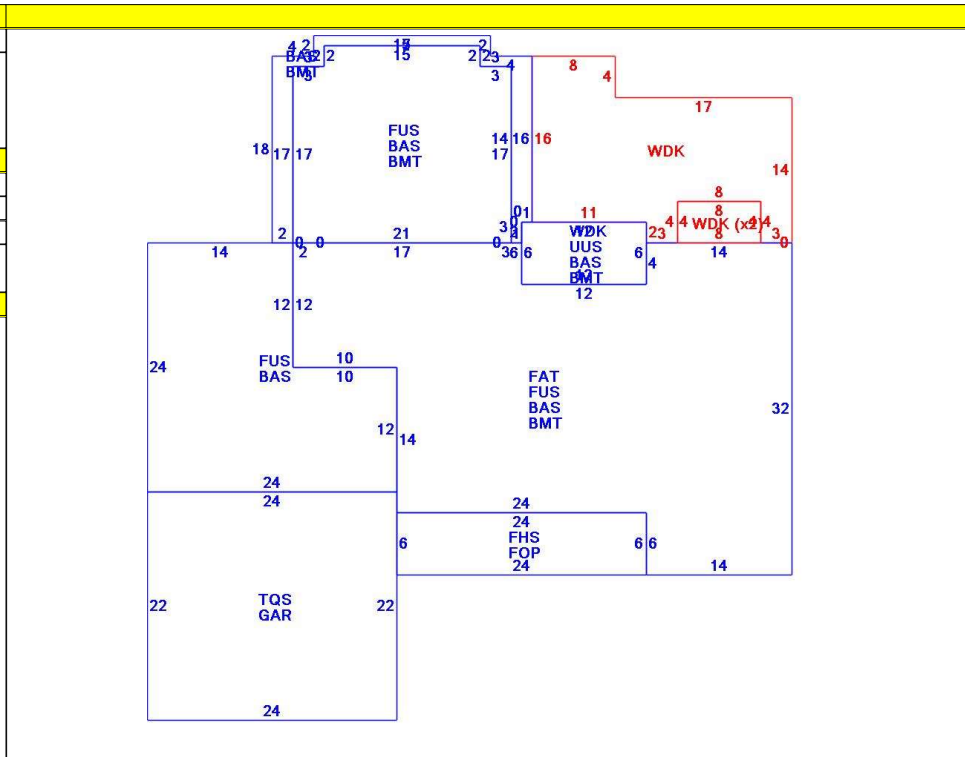

CONSTRUCTION DETAIL			CONSTRUCTION DETAIL (CONTINUED)		
Element	Cd	Description	Element	Cd	Description
Style	04	Cape Cod			
Model	01	Residential			
Grade:	A+	Luxury Plus			
Stories	2.4				
Exterior Wall 1	14	Wood Shingle			
Exterior Wall 2	11	Clapboard			
Roof Structure	03	Gable/Hip			
Roof Cover	03	Asph/F Gls/Cmp			
Interior Wall 1	05	Drywall			
Interior Wall 2					
Interior Floor 1	12	Hardwood			
Interior Floor 2					
Heat Fuel	03	Gas			
Heat Type	04	Hot Air			
AC Type	03	Central			
Bedrooms	06	6 Bedrooms			
Full Baths	4				
Half Baths	2				
Extra Fixtures					
Total Rooms	13				
Bath Style					
Kitchen Style					
Occupancy					
Usrflid 105					
Accessory Apt					
Foundation Alt	01	Poured Conc.			
Rms Prts					
Bath Split	42	4 Full-2 Half			
<b>CONDO DATA</b>					
Parcel Id		C	Ownr	0.0	
Adjust Type	Code	Description	Factor%		
Condo Fir					
Condo Unit					
<b>COST / MARKET VALUATION</b>					
Building Value New			2,022,845		
Year Built			2000		
Effective Year Built			2006		
Depreciation Code			A		
Remodel Rating					
Year Remodeled					
Depreciation %			10		
Functional Obsol			0		
External Obsol			0		
Trend Factor			1		
Condition					
Condition %					
Percent Good			90		
RCNLD			1,820,600		
Dep % Ovr					
Dep Ovr Comment					
Misc Imp Ovr					
Misc Imp Ovr Comment					
Cost to Cure Ovr					
Cost to Cure Ovr Comment					



OB - OUTBUILDING & YARD ITEMS(L) / XF - BUILDING EXTRA FEATURES(B)										
Code	Description	L/B	Units	Unit Price	Yr Blt	Cond. Cd	% Gd	Grade	Grade Adj.	Appr. Value
FPL3	Fireplace 2 sto	B	1	7000.00	2008		90		0.00	6,300
WDC	Wood Decking	L	464	20.00	2009		80		0.00	7,000
FOP	Open Porch-ro	B	144	55.00	2008		90		0.00	6,400
GAR	Attached Gara	B	528	40.00	2008		90		0.00	17,300
BMT	Basement-Unfi	B	1,698	26.01	2008		90		0.00	35,100
FPLG	Gas Fireplace-	B	2	2500.00	2008		90		0.00	4,500

BUILDING SUB-AREA SUMMARY SECTION						
Code	Description	Living Area	Floor Area	Eff Area	Unit Cost	Undeprec Value
BAS	First Floor	2,154	2,154	2,154	422.06	909,117
BMT	Basement Area	0	1,698	0	0.00	0
FAT	Attic, Finished	172	1,144	172	63.46	72,594
FHS	Half Story	72	144	72	211.03	30,388
FOP	Open Porch	0	144	0	0.00	0
FUS	Upper Story	1,987	1,987	1,987	422.06	838,633
GAR	Attached Garage	0	528	0	0.00	0
TQS	Three Quarter Story	343	528	343	274.18	144,767
UUS	Upper Story, Unfinished	0	72	61	357.58	25,746
WDK	Wood Deck	0	464	0	0.00	0
Ttl Gross Liv / Lease Area		4,728	8,863	4,789		2,021,245

