

CONSTRUCTION DETAIL			CONSTRUCTION DETAIL (CONTINUED)		
Element	Cd	Description	Element	Cd	Description
Style	04	Cape Cod			
Model	01	Residential			
Grade:	C	Average			
Stories	1.5	1 1/2 Stories			
Exterior Wall 1	14	Wood Shingle			
Exterior Wall 2					
RooF Structure	03	Gable/Hip			
RooF Cover	03	Asph/F Gls/Cmp			
Interior Wall 1	05	Drywall			
Interior Wall 2					
Interior Floor 1	14	Carpet			
Interior Floor 2					
Heat Fuel	02	Oil			
Heat Type	05	Hot Water			
AC Type	03	Central			
Bedrooms	03	3 Bedrooms			
Full Baths	2				
Half Baths	0				
Extra Fixtures					
Total Rooms	6	6 Rooms			
Bath Style					
Kitchen Style					
Occupancy					
Usrflid 105					
Accessory Apt					
Foundation Alt	08	Mixed			
Rms Prts					
Bath Split	20	2 Full-0 Half			

CONDO DATA			
Parcel Id	C	Ownr	0.0
Adjust Type	Code	Description	Factor%
Condo Flr			
Condo Unit			
COST / MARKET VALUATION			
Building Value New		398,477	
Year Built		1935	
Effective Year Built		1979	
Depreciation Code		A	
Remodel Rating			
Year Remodeled			
Depreciation %		31	
Functional Obsol		0	
External Obsol		0	
Trend Factor		1	
Condition			
Condition %			
Percent Good		69	
RCNLD		274,900	
Dep % Ovr			
Dep Ovr Comment			
Misc Imp Ovr			
Misc Imp Ovr Comment			
Cost to Cure Ovr			
Cost to Cure Ovr Comment			

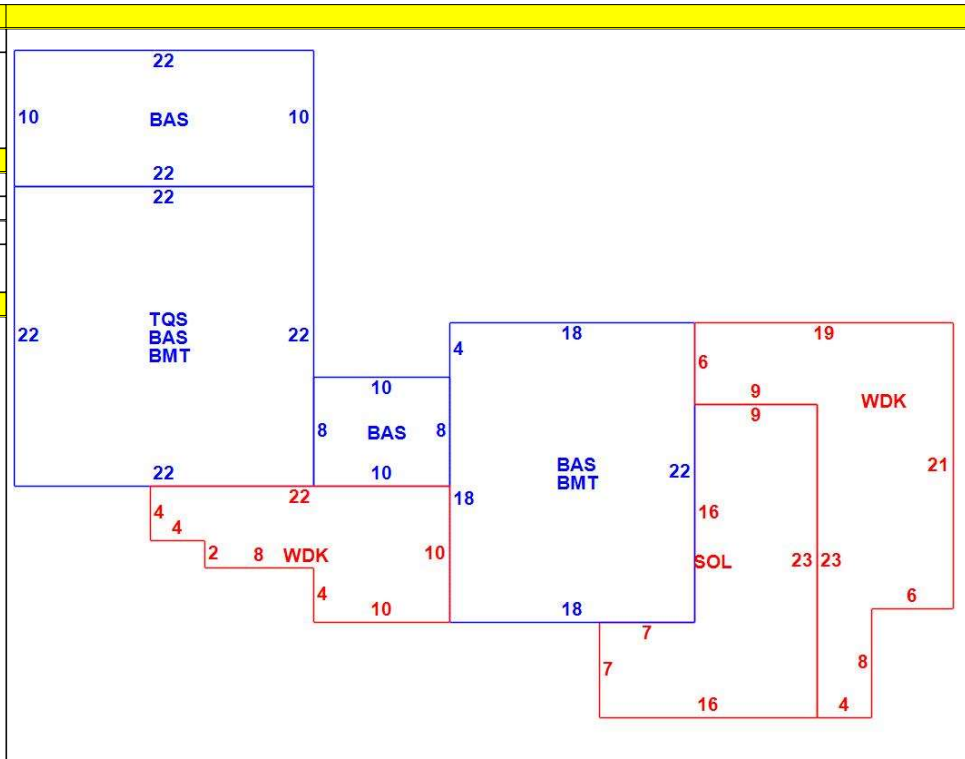

OB - OUTBUILDING & YARD ITEMS(L) / XF - BUILDING EXTRA FEATURES(B)										
Code	Description	L/B	Units	Unit Price	Yr Blt	Cond. Cd	% Gd	Grade	Grade Adj.	Appr. Value
FPL2	Fireplace 1.5 s	B	1	6000.00	1979		69		0.00	4,100
SOL	Solarium	L	256	171.10	1987		68	C	1.00	25,300
BMT	Basement-Unfi	B	880	26.01	1979		69		0.00	16,800
WDC	Wood Decking	L	164	20.00	2020		100		0.00	4,300
WDC	Wood Deck w/	L	296	18.00	2020		100		0.00	5,400

BUILDING SUB-AREA SUMMARY SECTION						
Code	Description	Living Area	Floor Area	Eff Area	Unit Cost	Undeprec Value
BAS	First Floor	1,180	1,180	1,180	266.54	314,517
BMT	Basement Area	0	880	0	0.00	0
SOL	Solarium	0	256	0	0.00	0
TQS	Three Quarter Story	315	484	315	173.47	83,960
WDK	Wood Deck	0	460	0	0.00	0
Ttl Gross Liv / Lease Area		1,495	3,260	1,495		398,477

