

CURRENT OWNER		TOPO	UTILITIES	STRT / ROAD	LOCATION	CURRENT ASSESSMENT				801 FY2024 BARNSTABLE, MA VISION
NOOK COTTAGE LLC PO BOX 564 WEST CHATHA MA 02669	1 Level	2 Public Water	3 Unpaved			Description	Code	Assessed	Assessed	
		4 Gas				RESIDNTL	1010	215,900	215,900	
		6 Septic				RES LAND	1010	205,300	205,300	
SUPPLEMENTAL DATA						Total				421,200
Alt Prcl ID Split Zonin BID Parcel ResExpt Q #DL 1 LOT 2 #DL 2 GIS ID F_976044_2704810				Plan Ref. 121/121 Land Ct# #SR Life Estate PP STATU Assoc Pid#						

RECORD OF OWNERSHIP		BK-VOL/PAGE	SALE DATE	Q/U	V/I	SALE PRIC	VC	PREVIOUS ASSESSMENTS (HISTORY)								
Year	Code	Assessed	Year	Code	Assessed	Year	Code	Assessed	Year	Code	Assessed					
NOOK COTTAGE LLC	28078	0105	04-09-2014	U	I	1	1A	2023	1010	181,900	2022	1010	153,200	2021	1010	117,100
WARDE, JONATHAN SCOTT, RUSSELL D	28078	0096	04-09-2014	U	I	0	1A		1010	186,700		1010	128,400		1010	130,400
WARDE, JOAN L ESTATE OF	26550	0306	08-01-2012	U	I	0	1								1010	2,200
WARDE, JOAN L	3051	0194	01-30-1980	U	I	0	1									
WARDE, DONALD F & JOAN L	1430	0732	03-18-1969	U		0										
Total								368,600	Total		281,600	Total		249,700		

EXEMPTIONS				OTHER ASSESSMENTS				This signature acknowledges a visit by a Data Collector or Assessor								
Year	Code	Description	Amount	Code	Description	Number	Amount	Comm Int								
Total			0.00													

ASSESSING NEIGHBORHOOD				APPRAISED VALUE SUMMARY			
Nbhd	Nbhd Name	B	Tracing	Batch			
0107				CENVIL	Appraised Bldg. Value (Card)	213,700	
					Appraised Xf (B) Value (Bldg)	0	
					Appraised Ob (B) Value (Bldg)	2,200	
					Appraised Land Value (Bldg)	205,300	
					Special Land Value	0	
					Total Appraised Parcel Value	421,200	
					Valuation Method	C	
					Total Appraised Parcel Value	421,200	

NOTES											VISIT / CHANGE HISTORY				
Permit Id	Issue Date	Type	Description	Amount	Insp Date	% Comp	Date Comp	Comments	Date	Id	Type	Is	Cd	Purpost/Result	
B29188	04-01-1986	AD	Addition	25,000	01-15-1987	100		CE ADD'N	07-14-2021	SR	02		03	Cycl Insp Comp	
									04-30-2020	WD			FR	Field Review	
									09-05-2014	AL	22		22	Change of Address	
									02-19-2010	NF	03		03	Cycl Insp Comp	
									01-28-2010	PT	02		14	Cyclical Inspection	
									12-11-2000	PT	01		00	Meas/Listed-Interior Acces	
									03-15-1987	JG					

LAND LINE VALUATION SECTION																	
B	Use Code	Description	Zone	LA	Land Units	Unit Price	Size Adj	AC Disc	Site Index	Cond.	Nbhd.	Nbhd. Adj	Notes	Location Adjustmen	Adj Unit P	Land Value	
1	1010	Single Fam M-0	RD-	3	0.230	AC	176,344.00	3.61599	1.0000	5	1.00	0107	1.400		1.0000	892,723.8	205,300
Total Card Land Units					0.23	AC	Parcel Total Land Area					0.23	Total Land Value			205,300	

CONSTRUCTION DETAIL			CONSTRUCTION DETAIL (CONTINUED)		
Element	Cd	Description	Element	Cd	Description
Style	01	Ranch			
Model	01	Residential			
Grade:	C	Average			
Stories	1	1 Story			
Exterior Wall 1	14	Wood Shingle			
Exterior Wall 2					
RooF Structure	03	Gable/Hip			
RooF Cover	03	Asph/F Gls/Cmp			
Interior Wall 1	05	Drywall			
Interior Wall 2					
Interior Floor 1	09	Pine/Soft Wood			
Interior Floor 2	14	Carpet			
Heat Fuel	03	Gas			
Heat Type	05	Hot Water			
AC Type	01	None			
Bedrooms	03	3 Bedrooms			
Full Baths	1				
Half Baths	0				
Extra Fixtures					
Total Rooms	6	6 Rooms			
Bath Style					
Kitchen Style					
Occupancy					
Usrflid 105					
Accessory Apt					
Foundation Alt	01	Poured Conc.			
Rms Prts					
Bath Split	10	1 Full-0 Half			

CONDO DATA				
Parcel Id		C	Ownr	0.0
Adjust Type	Code	Description	Factor%	
Condo Flr				
Condo Unit				

COST / MARKET VALUATION	
Building Value New	309,722
Year Built	1928
Effective Year Built	1979
Depreciation Code	A
Remodel Rating	
Year Remodeled	
Depreciation %	31
Functional Obsol	0
External Obsol	0
Trend Factor	1
Condition	
Condition %	
Percent Good	69
RCNLD	213,700
Dep % Ovr	
Dep Ovr Comment	
Misc Imp Ovr	
Misc Imp Ovr Comment	
Cost to Cure Ovr	
Cost to Cure Ovr Comment	

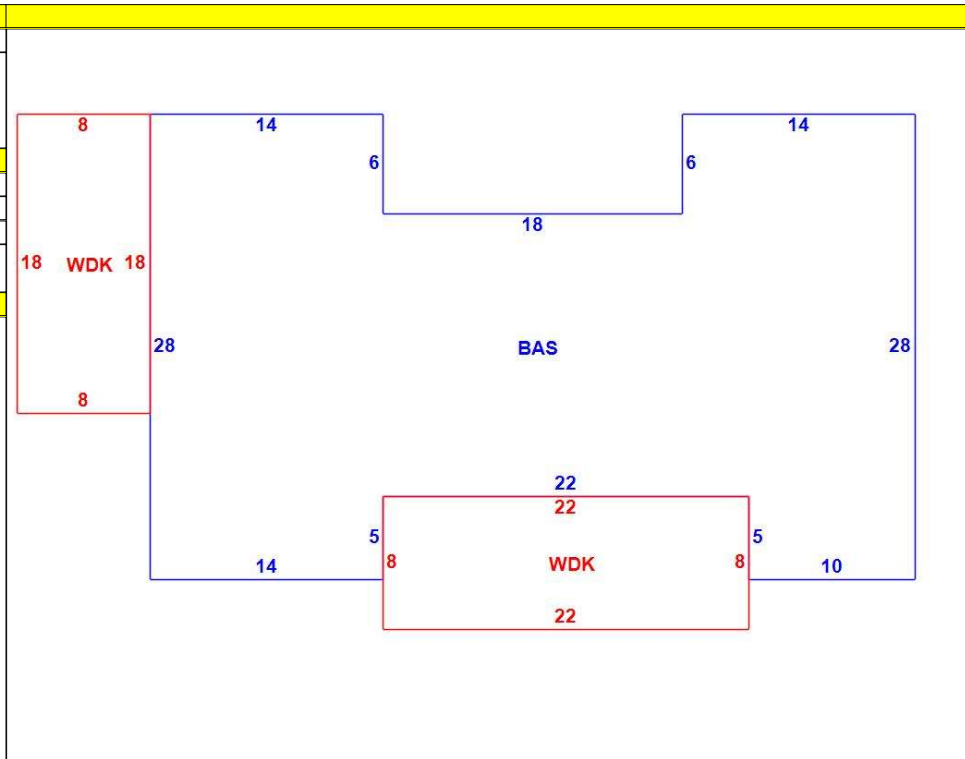

OB - OUTBUILDING & YARD ITEMS(L) / XF - BUILDING EXTRA FEATURES(B)										
Code	Description	L/B	Units	Unit Price	Yr Blt	Cond. Cd	% Gd	Grade	Grade Adj.	Appr. Value
WDC	Wood Decking	L	320	20.00	1986		34		0.00	2,200

BUILDING SUB-AREA SUMMARY SECTION						
Code	Description	Living Area	Floor Area	Eff Area	Unit Cost	Undeprec Value
BAS	First Floor	1,070	1,070	1,070	289.46	309,722
WDC	Wood Deck	0	320	0	0.00	0
Ttl Gross Liv / Lease Area		1,070	1,390	1,070		309,722

