

CONSTRUCTION DETAIL			CONSTRUCTION DETAIL (CONTINUED)		
Element	Cd	Description	Element	Cd	Description
Style	01	Ranch			
Model	01	Residential			
Grade:	C+	Average Plus			
Stories	1	1 Story			
Exterior Wall 1	14	Wood Shingle			
Exterior Wall 2					
RooF Structure	03	Gable/Hip			
RooF Cover	03	Asph/F Gls/Cmp			
Interior Wall 1	05	Drywall			
Interior Wall 2	07	Knotty Pine			
Interior Floor 1	12	Hardwood			
Interior Floor 2					
Heat Fuel	03	Gas			
Heat Type	04	Hot Air			
AC Type	03	Central			
Bedrooms	04	4 Bedrooms			
Full Baths	3				
Half Baths	0				
Extra Fixtures					
Total Rooms	9	9 Rooms			
Bath Style					
Kitchen Style					
Occupancy					
UsrflD 105					
Accessory Apt					
Foundation Alt	01	Poured Conc.			
Rms Prts					
Bath Split	30	3 Full-0 Half			
CONDO DATA			COST / MARKET VALUATION		
Parcel Id		C	Ownr	0.0	
Adjust Type	Code	Description	Factor%		
Condo Flr					
Condo Unit					
Building Value New		672,554			
Year Built		1975			
Effective Year Built		2013			
Depreciation Code		E			
Remodel Rating					
Year Remodeled					
Depreciation %		5			
Functional Obsol		0			
External Obsol		0			
Trend Factor		1			
Condition					
Condition %					
Percent Good		95			
RCNLD		638,900			
Dep % Ovr					
Dep Ovr Comment					
Misc Imp Ovr					
Misc Imp Ovr Comment					
Cost to Cure Ovr					
Cost to Cure Ovr Comment					

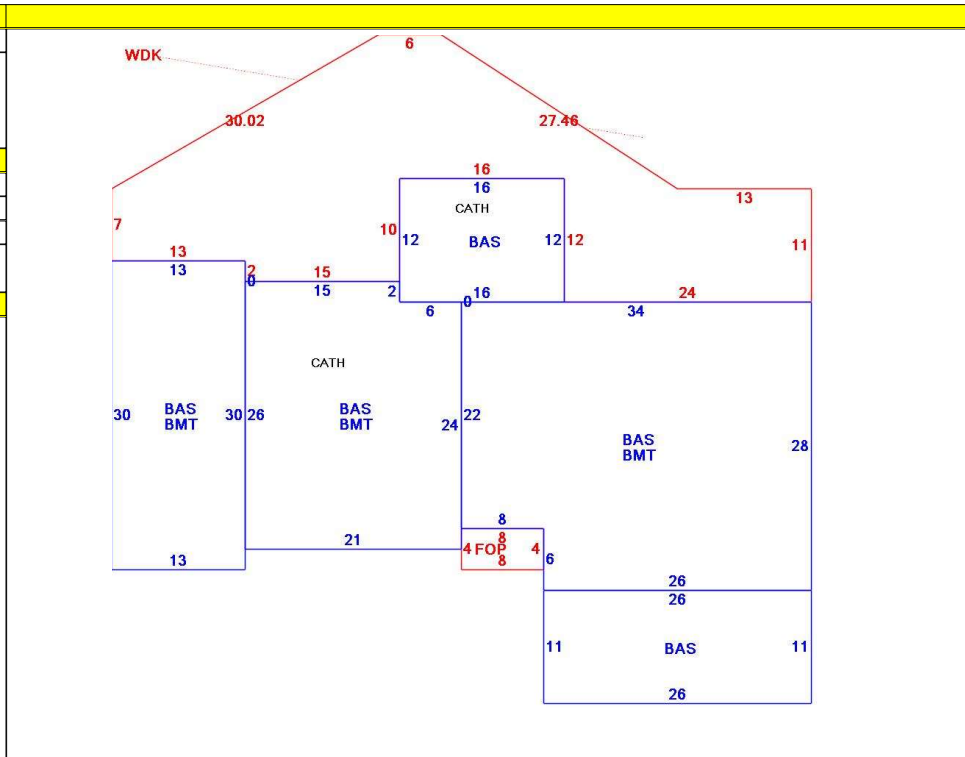

OB - OUTBUILDING & YARD ITEMS(L) / XF - BUILDING EXTRA FEATURES(B)										
Code	Description	L/B	Units	Unit Price	Yr Blt	Cond. Cd	% Gd	Grade	Grade Adj.	Appr. Value
FPL1	Fireplace 1 sto	B	1	5000.00	2015		95		0.00	4,800
DKPL	Pond Dock-Lig	L	1	4200.00	2000		100		0.00	4,200
WDC	Deck comp w	L	932	28.00	1997		56		0.00	13,100
FOP	Open Porch-ro	B	32	55.00	2015		95		0.00	2,400
BMT	Basement-Unfi	B	1,828	26.01	2015		95		0.00	39,400
BFA1	Bsmt Fin-Goo	B	1,154	32.56	2015		95		0.00	35,700
GEN	Emergency Ge	L	1	5550.00	2014		90		0.00	5,000
FPLG	Gas Fireplace-	B	1	2500.00	2015		95		0.00	2,400
SHED	Shed	L	192	18.00	2015		92		0.00	3,200

BUILDING SUB-AREA SUMMARY SECTION						
Code	Description	Living Area	Floor Area	Eff Area	Unit Cost	Undeprec Value
BAS	First Floor	2,306	2,306	2,306	291.65	672,554
BMT	Basement Area	0	1,828	0	0.00	0
FOP	Open Porch	0	32	0	0.00	0
WDK	Wood Deck	0	932	0	0.00	0
Ttl Gross Liv / Lease Area		2,306	5,098	2,306		672,554

