

CURRENT OWNER		TOPO	UTILITIES	STRT / ROAD	LOCATION	CURRENT ASSESSMENT				801 FY2024 BARNSTABLE, MA  <b>VISION</b>
MENZIN, ELEANOR R TR 219 NYES NECK ROAD NOMINEE TR 30 NARDELL ROAD		1 Level	5 Well	1 Paved	1 Lake/Pond Fro	Description	Code	Assessed	Assessed	
			6 Septic		1 Excel View	RESIDNTL	1010	721,000	721,000	
NEWTON MA 02460		<b>SUPPLEMENTAL DATA</b>				RES LAND	1010	1,139,900	1,139,900	
		Alt Prcl ID Split Zonin BID Parcel ResExpt Q #DL 1 LOT 3 #DL 2 GIS ID F_973412_2709036	Plan Ref. 330/27 Land Ct# #SR Life Estate PP STATU A:Active Assoc Pid#	Total		1,860,900	1,860,900			

RECORD OF OWNERSHIP		BK-VOL/PAGE	SALE DATE	Q/U	V/I	SALE PRIC	VC	PREVIOUS ASSESSMENTS (HISTORY)								
MENZIN, ELEANOR R TR MENZIN, MARVIN DESIGN, TECHNOLOGYCORP		33629 0245	12-30-2020	U	I	100	1F	Year	Code	Assessed	Year	Code	Assessed	Year	Code	Assessed
		4302 0143	10-31-1984	Q	I	55,000	U	2023	1010	576,700	2022	1010	535,100	2021	1010	462,900
		3256 0042	03-19-1981	U		0			1010	1,036,200		1010	560,900		1010	543,200
		Total						1,612,900		Total		1,096,000		Total		1,016,700

EXEMPTIONS			OTHER ASSESSMENTS					This signature acknowledges a visit by a Data Collector or Assessor										
Year	Code	Description	Amount	Code	Description	Number	Amount	Comm Int										
		Total	0.00															

ASSESSING NEIGHBORHOOD				APPRAISED VALUE SUMMARY					
Nbhd	Nbhd Name	B	Tracing	Batch					
0114				CENVIL					
NOTES				Appraised Bldg. Value (Card)	617,000				
				Appraised Xf (B) Value (Bldg)	92,700				
				Appraised Ob (B) Value (Bldg)	11,300				
				Appraised Land Value (Bldg)	1,139,900				
				Special Land Value	0				
				Total Appraised Parcel Value	1,860,900				
				Valuation Method	C				
				Total Appraised Parcel Value	1,860,900				

BUILDING PERMIT RECORD									VISIT / CHANGE HISTORY					
Permit Id	Issue Date	Type	Description	Amount	Insp Date	% Comp	Date Comp	Comments	Date	Id	Type	Is	Cd	Purpost/Result
18-2878 B34112	08-31-2018 12-01-1990	822 DW	Insulation Dwelling	2,071 300,000	06-30-2019 01-15-1991	100 100	06-30-2019	Weatherization, weather strippi CE 1 STOR	07-20-2021 04-29-2020 07-20-2015 01-03-2001 11-03-2000	SR WD TP PT PT	01  03 01 02		03 FR 16 00 01	Cycl Insp Comp Field Review In Office Review Meas/Listed-Interior Acces Meas/Est

LAND LINE VALUATION SECTION																	
B	Use Code	Description	Zone	LA	Land Units	Unit Price	Size Adj	AC Disc	Site Index	Cond.	Nbhd.	Nbhd. Adj	Notes	Location Adjustmen	Adj Unit P	Land Value	
1	1010	Single Fam M-0	RD-	3	0.940 AC	176,344.00	1.05790	1.0000	5	1.00	0114	6.500	WEQUAQUET LAKE		1.0000	1,212,611	
Total Card Land Units					0.94 AC	Parcel Total Land Area					0.94	Total Land Value					1,139,900

CONSTRUCTION DETAIL			CONSTRUCTION DETAIL (CONTINUED)		
Element	Cd	Description	Element	Cd	Description
Style	07	Modern/Contemp			
Model	01	Residential			
Grade:	B	Custom			
Stories	1	1 Story			
Exterior Wall 1	14	Wood Shingle			
Exterior Wall 2					
RooF Structure	03	Gable/Hip			
RooF Cover	03	Asph/F Gls/Cmp			
Interior Wall 1	03	Plastered			
Interior Wall 2					
Interior Floor 1	14	Carpet			
Interior Floor 2	12	Hardwood			
Heat Fuel	02	Oil			
Heat Type	05	Hot Water			
AC Type	03	Central			
Bedrooms	03	3 Bedrooms			
Full Baths	3				
Half Baths	0				
Extra Fixtures					
Total Rooms	5	5 Rooms			
Bath Style					
Kitchen Style					
Occupancy					
Usrflid 105					
Accessory Apt					
Foundation Alt	01	Poured Conc.			
Rms Prts					
Bath Split	30	3 Full-0 Half			
			<b>CONDO DATA</b>		
			Parcel Id	C	Owne 0.0
			Adjust Type	Code	Description
			Condo Flr		
			Condo Unit		
			<b>COST / MARKET VALUATION</b>		
			Building Value New		717,433
			Year Built		1991
			Effective Year Built		2001
			Depreciation Code		A
			Remodel Rating		
			Year Remodeled		
			Depreciation %		14
			Functional Obsol		0
			External Obsol		0
			Trend Factor		1
			Condition		
			Condition %		
			Percent Good		86
			RCNLD		617,000
			Dep % Ovr		
			Dep Ovr Comment		
			Misc Imp Ovr		
			Misc Imp Ovr Comment		
			Cost to Cure Ovr		
			Cost to Cure Ovr Comment		

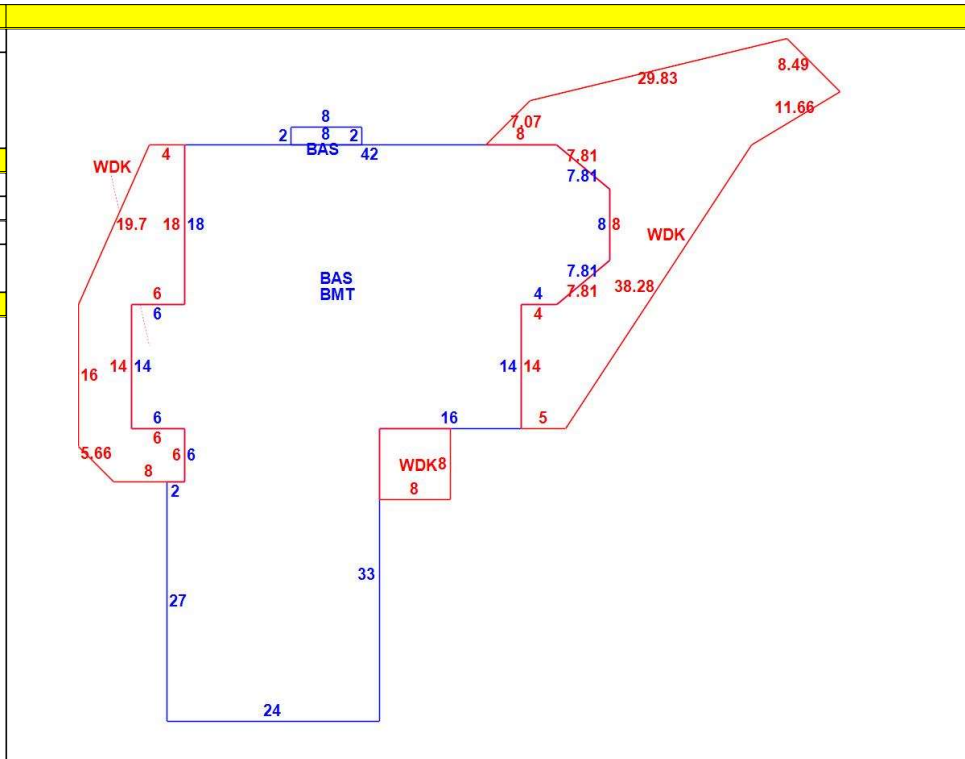

OB - OUTBUILDING & YARD ITEMS(L) / XF - BUILDING EXTRA FEATURES(B)										
Code	Description	L/B	Units	Unit Price	Yr Blt	Cond. Cd	% Gd	Grade	Grade Adj.	Appr. Value
FPL1	Fireplace 1 sto	B	1	5000.00	2003		86		0.00	4,300
FPO	Ext FP Openin	B	1	2000.00	2003		86		0.00	1,700
BGR2	2 Stall Bmt Ga	B	1	3244.00	2003		86		0.00	2,800
BFA1	Bsmt Fin-Goo	B	1,500	32.56	2003		86		0.00	42,000
WDC	Wood Decking	L	985	20.00	2001		64		0.00	11,300
BMT	Basement-Unfi	B	2,230	26.01	2003		86		0.00	41,900

BUILDING SUB-AREA SUMMARY SECTION						
Code	Description	Living Area	Floor Area	Eff Area	Unit Cost	Undeprec Value
BAS	First Floor	2,246	2,246	2,246	319.43	717,433
BMT	Basement Area	0	2,230	0	0.00	0
WDC	Wood Deck	0	985	0	0.00	0
Ttl Gross Liv / Lease Area		2,246	5,461	2,246		717,433

