

| CURRENT OWNER | | TOPO | UTILITIES | STRT / ROAD | LOCATION | CURRENT ASSESSMENT | | | | | |
|---|--|---------|----------------|-------------|---|--------------------|-------|----------|----------|-----------|-----------|
| HIRTZ, SIEGFRIED & MARGARET TR HIRTZ REALTY TRUST 87 POND SIDE CIRCLE CENTERVILLE MA 02632 | | 1 Level | 2 Public Water | 1 Paved | 1 Lake/Pond Fro | Description | Code | Assessed | Assessed | | |
| | | | 4 Gas | | 1 Excel View | RESIDENTL | 1010 | 766,400 | 766,400 | | |
| | | | 6 Septic | | | RES LAND | 1010 | 539,000 | 539,000 | | |
| SUPPLEMENTAL DATA | | | | | | | | | | | |
| Alt Prcl ID Split Zonin BID Parcel ResExpt Q YES: #DL 1 LOT 9 #DL 2 GIS ID F_976003_2709930 | | | | | Plan Ref. 440/27-29 Land Ct# #SR Life Estate PP STATU Assoc Pid# | | Total | | | 1,305,400 | 1,305,400 |

801
FY2024
BARNSTABLE, MA
VISION

| RECORD OF OWNERSHIP | | BK-VOL/PAGE | SALE DATE | Q/U | V/I | SALE PRIC | VC | PREVIOUS ASSESSMENTS (HISTORY) | | | | | | | | | | | | | |
|---------------------------------|--|-------------|------------|-----|-----|-----------|----|--------------------------------|------|----------|------|------|----------|------|------|----------|-----------|-------|---------|-------|---------|
| HIRTZ, SIEGFRIED & MARGARET TRS | | 31962 0312 | 04-19-2019 | U | I | 1 | 1F | Year | Code | Assessed | Year | Code | Assessed | Year | Code | Assessed | | | | | |
| HIRTZ, SIEGFRIED & MARGARET | | 8706 0088 | 07-15-1993 | Q | I | 279,000 | U | 2023 | 1010 | 662,900 | 2022 | 1010 | 582,000 | 2021 | 1010 | 466,800 | | | | | |
| THEO CONSTRUCTION CO INC | | 8017 0010 | 05-15-1992 | U | V | 90,000 | B | | 1010 | 634,600 | | 1010 | 357,500 | | 1010 | 381,300 | | | | | |
| ELDRIDGE, ANDREW F TR | | 7952 0218 | 04-15-1992 | U | V | 780,000 | N | | | | | | | | 1010 | 10,500 | | | | | |
| THEOHARIDIS, SPERO TRS | | 5984 0135 | 10-15-1987 | U | V | 1 | B | Total | | | | | | | | | 1,297,500 | Total | 939,500 | Total | 858,600 |

| EXEMPTIONS | | | | OTHER ASSESSMENTS | | | |
|------------|------|-----------------------|--------|---|-------------|--------|--------|
| Year | Code | Description | Amount | Code | Description | Number | Amount |
| 2011 | 5C | RESIDENTIAL EXEMPTION | 0.00 | | | | |
| Total | | | 0.00 | This signature acknowledges a visit by a Data Collector or Assessor | | | |

| ASSESSING NEIGHBORHOOD | | | | APPRAISED VALUE SUMMARY | | | |
|------------------------|-----------|---|---------|--|--|--|--|
| Nbhd | Nbhd Name | B | Tracing | Batch | | | |
| 0111 | | | | CENVIL | | | |
| NOTES | | | | Appraised Bldg. Value (Card) 650,800 | | | |
| | | | | Appraised Xf (B) Value (Bldg) 105,100 | | | |
| | | | | Appraised Ob (B) Value (Bldg) 10,500 | | | |
| | | | | Appraised Land Value (Bldg) 539,000 | | | |
| | | | | Special Land Value 0 | | | |
| | | | | Total Appraised Parcel Value 1,305,400 | | | |
| | | | | Valuation Method C | | | |
| | | | | Total Appraised Parcel Value 1,305,400 | | | |

| BUILDING PERMIT RECORD | | | | | | | | | VISIT / CHANGE HISTORY | | | | | |
|------------------------|------------|------|----------------|---------|------------|--------|------------|------------------------|------------------------|----|------|----|----|----------------------------|
| Permit Id | Issue Date | Type | Description | Amount | Insp Date | % Comp | Date Comp | Comments | Date | Id | Type | Is | Cd | Purpost/Result |
| 201106880 | 03-14-2012 | PV | Solar PV Syste | 4,000 | 04-04-2014 | 100 | 06-30-2014 | PV SOLAR PANEL ARRAY O | 04-30-2020 | WD | | | FR | Field Review |
| 200901960 | 05-05-2009 | NR | New Roof | 16,450 | 06-30-2009 | 100 | 06-30-2009 | REROOF, STRP OLD SHNGL | 04-16-2014 | MW | 01 | | 02 | Bldg Permit Completed |
| B35315 | 08-01-1992 | DW | Dwelling | 150,000 | 01-15-1995 | 100 | 06-30-1995 | CE 1 STOR | 11-07-2000 | PT | 01 | | 00 | Meas/Listed-Interior Acces |
| | | | | | | | | | 05-15-1993 | ML | 01 | | 00 | Meas/Listed-Interior Acces |

| LAND LINE VALUATION SECTION | | | | | | | | | | | | | | | | | |
|-----------------------------|----------|----------------|------|----|------------|------------------------|----------|---------|------------|-------|-------|------------------|--------------|--------------------|------------|------------|---------|
| B | Use Code | Description | Zone | LA | Land Units | Unit Price | Size Adj | AC Disc | Site Index | Cond. | Nbhd. | Nbhd. Adj | Notes | Location Adjustmen | Adj Unit P | Land Value | |
| 1 | 1010 | Single Fam M-0 | RD- | 3 | 1.000 AC | 176,344.00 | 1.00000 | 1.0000 | 5 | 1.00 | 0111 | 3.050 | SHALLOW POND | | 1.0000 | 537,849.2 | |
| 1 | 1010 | Single Fam M-0 | RD- | 3 | 0.010 AC | 14,250.00 | 1.00000 | 1.0000 | 0 | 1.00 | 0111 | 3.050 | RESIDUAL | | 1.0000 | 43,462.5 | |
| 1 | 1010 | Single Fam M-0 | RD- | 3 | 0.350 AC | 2,375.00 | 1.00000 | 1.0000 | 0 | 1.00 | WTLD | 1.000 | WETLAND | | 1.0000 | 2,375 | |
| Total Card Land Units | | | | | 1.36 AC | Parcel Total Land Area | | | | | 1.36 | Total Land Value | | | | | 539,000 |

| CONSTRUCTION DETAIL | | | CONSTRUCTION DETAIL (CONTINUED) | | |
|---------------------|----|----------------|---------------------------------|----|-------------|
| Element | Cd | Description | Element | Cd | Description |
| Style | 01 | Ranch | | | |
| Model | 01 | Residential | | | |
| Grade: | C+ | Average Plus | | | |
| Stories | 1 | 1 Story | | | |
| Exterior Wall 1 | 14 | Wood Shingle | | | |
| Exterior Wall 2 | 11 | Clapboard | | | |
| RooF Structure | 03 | Gable/Hip | | | |
| RooF Cover | 03 | Asph/F Gls/Cmp | | | |
| Interior Wall 1 | 05 | Drywall | | | |
| Interior Wall 2 | | | | | |
| Interior Floor 1 | 14 | Carpet | | | |
| Interior Floor 2 | 12 | Hardwood | | | |
| Heat Fuel | 03 | Gas | | | |
| Heat Type | 05 | Hot Water | | | |
| AC Type | 03 | Central | | | |
| Bedrooms | 03 | 3 Bedrooms | | | |
| Full Baths | 2 | | | | |
| Half Baths | 1 | | | | |
| Extra Fixtures | | | | | |
| Total Rooms | 6 | 6 Rooms | | | |
| Bath Style | | | | | |
| Kitchen Style | | | | | |
| Occupancy | | | | | |
| Usrflid 105 | | | | | |
| Accessory Apt | | | | | |
| Foundation Alt | 01 | Poured Conc. | | | |
| Rms Prts | | | | | |
| Bath Split | 21 | 2 Full-1 Half | | | |

| CONDO DATA | | | |
|-------------|------|-------------|---------|
| Parcel Id | C | Owne | 0.0 |
| Adjust Type | Code | Description | Factor% |
| Condo Flr | | | |
| Condo Unit | | | |

| COST / MARKET VALUATION | |
|--------------------------|---------|
| Building Value New | 748,072 |
| Year Built | 1992 |
| Effective Year Built | 2002 |
| Depreciation Code | A |
| Remodel Rating | |
| Year Remodeled | |
| Depreciation % | 13 |
| Functional Obsol | 0 |
| External Obsol | 0 |
| Trend Factor | 1 |
| Condition | |
| Condition % | |
| Percent Good | 87 |
| RCNLD | 650,800 |
| Dep % Ovr | |
| Dep Ovr Comment | |
| Misc Imp Ovr | |
| Misc Imp Ovr Comment | |
| Cost to Cure Ovr | |
| Cost to Cure Ovr Comment | |

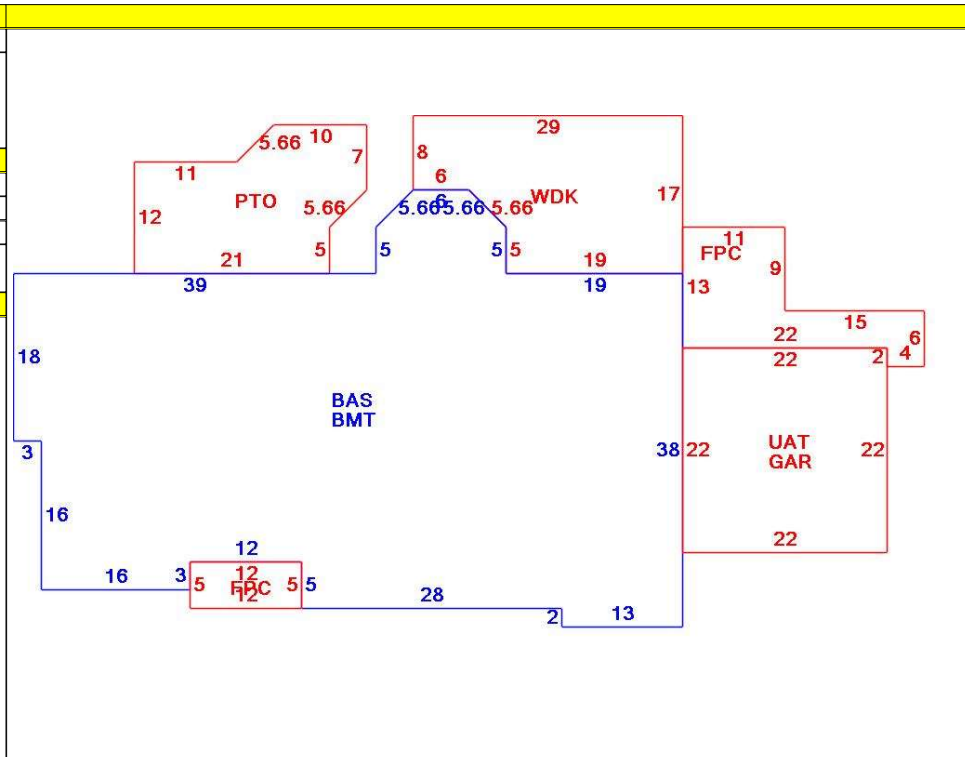

| OB - OUTBUILDING & YARD ITEMS(L) / XF - BUILDING EXTRA FEATURES(B) | | | | | | | | | | |
|--|-----------------|-----|-------|------------|--------|----------|------|-------|------------|-------------|
| Code | Description | L/B | Units | Unit Price | Yr Blt | Cond. Cd | % Gd | Grade | Grade Adj. | Appr. Value |
| FPL2 | Fireplace 1.5 s | B | 1 | 6000.00 | 2004 | | 87 | | 0.00 | 5,200 |
| BFA | Bsmt Fin-Avg | B | 1,800 | 17.36 | 2004 | | 87 | | 0.00 | 27,200 |
| WDC | Wood Decking | L | 411 | 20.00 | 2001 | | 64 | | 0.00 | 5,100 |
| GAR | Attached Gara | B | 484 | 40.00 | 2004 | | 87 | | 0.00 | 15,800 |
| BMT | Basement-Unfi | B | 2,582 | 26.01 | 2004 | | 87 | | 0.00 | 47,800 |
| PAT1 | Patio- Average | L | 320 | 5.89 | 2002 | | 83 | | 0.00 | 1,600 |
| FOPC | Open Prch-roo | B | 271 | 55.00 | 2004 | | 87 | | 0.00 | 9,100 |
| GRN1 | Greenhouse-R | L | 96 | 60.75 | 2002 | | 66 | C | 1.00 | 3,800 |
| SOL1 | Solar PV Pane | B | 30 | 860.00 | 2004 | | 0 | | 0.00 | 0 |

| BUILDING SUB-AREA SUMMARY SECTION | | | | | | |
|-----------------------------------|------------------------|-------------|------------|----------|-----------|----------------|
| Code | Description | Living Area | Floor Area | Eff Area | Unit Cost | Undeprec Value |
| BAS | First Floor | 2,582 | 2,582 | 2,582 | 284.44 | 734,419 |
| BMT | Basement Area | 0 | 2,582 | 0 | 0.00 | 0 |
| FPC | Open Porch Conc. Floor | 0 | 271 | 0 | 0.00 | 0 |
| GAR | Attached Garage | 0 | 484 | 0 | 0.00 | 0 |
| PTO | Patio | 0 | 320 | 0 | 0.00 | 0 |
| UAT | Attic, Unfinished | 0 | 484 | 48 | 28.21 | 13,653 |
| WDK | Wood Deck | 0 | 411 | 0 | 0.00 | 0 |
| Ttl Gross Liv / Lease Area | | 2,582 | 7,134 | 2,630 | | 748,072 |

