

| CURRENT OWNER   |            | TOPO                     | UTILITIES         | STRT / ROAD | LOCATION         | CURRENT ASSESSMENT                     |   |                                    |            | 801<br>FY2024<br>BARNSTABLE, MA<br><br><b>VISION</b> |       |                        |                  |       |                       |            |            |           |
|---|------------|--------------------------|-------------------|-------------|------------------|--|---|------------------------------------|------------|--|-------|------------------------|------------------|-------|-----------------------|------------|------------|-----------|
| CONDON, MARGARET M & CHRISTOPHER<br>CONDON 2019 RESIDENCE TRUST<br>343 EL BRILLO<br><br>PALM BEACH FL 33480 |            | 1 Level                  | 2 Public Water    | 1 Paved     | 7 Waterfront     | Description<br>RESIDENTIAL<br>RES LAND | Code<br>1010<br>1010  | Assessed<br>3,276,200<br>5,055,400 | Assessed   |  |       | 3,276,200<br>5,055,400 |                  |       |                       |            |            |           |
|   |            |                          | 4 Gas             |             | 1 Excel View     |  |   |                                    |            |  |       |                        |                  |       |                       |            |            |           |
|   |            | <b>SUPPLEMENTAL DATA</b> |                   |             |                  |  |   | Total                              |            |  |       |                        |                  |       |                       |            |            |           |
|   |            | Alt Prcl ID              | Split Zonin       |             | Plan Ref. 187/19 |  |   |                                    |            |  |       |                        |                  |       |                       |            |            |           |
|   |            | BID Parcel               | ResExpt Q         |             | Land Ct#         |  |   |                                    |            |  |       |                        |                  |       |                       |            |            |           |
|   |            | #DL 1 UNNUM LOT          |                   |             | #SR              |  |   |                                    |            |  |       |                        |                  |       |                       |            |            |           |
|   |            | #DL 2                    |                   |             | Life Estate      |  |   |                                    |            |  |       |                        |                  |       |                       |            |            |           |
|   |            | GIS ID F_976450_2694140  |                   |             | PP STATU         |  |   |                                    |            |  |       |                        |                  |       |                       |            |            |           |
|   |            |                          |                   |             | Assoc Pid#       |  |   |                                    |            |  |       |                        |                  |       |                       |            |            |           |
| RECORD OF OWNERSHIP   |            | BK-VOL/PAGE              | SALE DATE         | Q/U         | V/I              | SALE PRIC                              | VC  | PREVIOUS ASSESSMENTS (HISTORY)     |            |  |       |                        |                  |       |                       |            |            |           |
| CONDON, MARGARET M & CHRISTOPHER  |            | 32014 0001               | 05-13-2019        | U           | I                | 100                                    | 1F  | Year                               | Code       | Assessed   | Year  | Code                   | Assessed         | Year  | Code                  | Assessed   |            |           |
| CONDON, MARGARET M  |            | 31850 0058               | 02-22-2019        | U           | I                | 100                                    | 1F  | 2023                               | 1010       | 2,819,800  | 2022  | 1010                   | 2,373,800        | 2021  | 1010                  | 1,655,300  |            |           |
| CONDON, CHRISTOPHER M & MARGA ENTE, BASILA & HELENA ENTE, BASILA  |            | 10145 0202               | 04-11-1996        | Q           | I                | 1,477,000                              | 00  |                                    | 1010       | 4,638,600  |       | 1010                   | 3,558,000        |       | 1010                  | 3,284,300  |            |           |
|   |            | 6602 0180                | 01-23-1989        | U           | I                | 1                                      | A   |                                    |            |  |       |                        |                  |       | 1010                  | 355,600    |            |           |
|   |            | 3103 0347                | 05-30-1980        | U           |                  | 0                                      |   | Total                              |            | 7,458,400  | Total |                        | 5,931,800        | Total |                       | 5,295,200  |            |           |
| EXEMPTIONS  |            |                          | OTHER ASSESSMENTS |             |                  |  | This signature acknowledges a visit by a Data Collector or Assessor |                                    |            |  |       |                        |                  |       |                       |            |            |           |
| Year  | Code       | Description              | Amount            | Code        | Description      | Number                                 | Amount  | Comm Int                           |            |  |       |                        |                  |       |                       |            |            |           |
|   |            |                          | Total             | 0.00        |                  |  |   |                                    |            |  |       |                        |                  |       |                       |            |            |           |
| ASSESSING NEIGHBORHOOD  |            |                          |                   |             |                  |  |   |                                    |            | <b>APPRAISED VALUE SUMMARY</b>                       |       |                        |                  |       |                       |            |            |           |
| Nbhd  | Nbhd Name  |                          | B                 |             | Tracing          |  | Batch   |                                    |            | Appraised Bldg. Value (Card)                         |       |                        |                  |       |                       | 2,822,300  |            |           |
| WF10  |            |                          |                   |             |                  |  | CENVIL  |                                    |            | Appraised Xf (B) Value (Bldg)                        |       |                        |                  |       |                       | 98,300     |            |           |
|   |            |                          |                   |             |                  |  |   |                                    |            | Appraised Ob (B) Value (Bldg)                        |       |                        |                  |       |                       | 355,600    |            |           |
|   |            |                          |                   |             |                  |  |   |                                    |            | Appraised Land Value (Bldg)                          |       |                        |                  |       |                       | 5,055,400  |            |           |
|   |            |                          |                   |             |                  |  |   |                                    |            | Special Land Value                                   |       |                        |                  |       |                       | 0          |            |           |
|   |            |                          |                   |             |                  |  |   |                                    |            | Total Appraised Parcel Value                         |       |                        |                  |       |                       | 8,331,600  |            |           |
|   |            |                          |                   |             |                  |  |   |                                    |            | Valuation Method                                     |       |                        |                  |       |                       | C          |            |           |
|   |            |                          |                   |             |                  |  |   |                                    |            | Total Appraised Parcel Value                         |       |                        |                  |       |                       | 8,331,600  |            |           |
| BUILDING PERMIT RECORD  |            |                          |                   |             |                  |  |   |                                    |            | VISIT / CHANGE HISTORY                               |       |                        |                  |       |                       |            |            |           |
| Permit Id   | Issue Date | Type                     | Description       | Amount      | Insp Date        | % Comp                                 | Date Comp   | Comments                           |            | Date   | Id    | Type                   | Is               | Cd    | Purpost/Result        |            |            |           |
| 201201728   | 03-20-2012 | OT                       | Other             | 50,000      | 02-01-2013       | 100                                    | 06-30-2013  | ADD 3'10" TO GAR FND-ADD           |            | 02-01-2021   | CK    | 22                     |                  | 22    | Change of Address     |            |            |           |
| 201106649   | 12-12-2011 | RE                       | Remodel           | 1,500,000   | 07-17-2013       | 100                                    | 06-30-2014  | REMOD ENTIRE INTERIOR-             |            | 05-20-2020   | WD    |                        |                  | FR    | Field Review          |            |            |           |
| 200707219   | 11-13-2007 | DG                       | Detached Gara     | 295,000     | 04-02-2008       | 100                                    | 06-30-2008  | New detach gar w/living upstai     |            | 06-21-2016   | AL    | 03                     |                  | 16    | In Office Review      |            |            |           |
| 200707218   | 11-13-2007 | DE                       | Demolish          | 6,500       | 04-02-2008       | 100                                    | 06-30-2008  | Demo'd old garage/upper sty        |            | 02-17-2015   | AL    | 22                     |                  | 22    | Change of Address     |            |            |           |
| 59859   | 03-18-2002 | NW                       | New Windows       | 7,000       | 10-02-2002       | 100                                    | 01-01-2003  |                                    |            | 06-19-2014   | JR    | 03                     |                  | 16    | In Office Review      |            |            |           |
| 46808   | 06-15-2000 | RE                       | Remodel           | 25,000      | 01-01-2001       | 100                                    | 12-31-2001  | REM TOWER                          |            | 02-05-2014   | MW    | 01                     |                  | 02    | Bldg Permit Completed |            |            |           |
| 40649   | 08-25-1999 | SP                       | Swimming Pool     | 25,000      | 06-16-2000       | 100                                    | 11-08-1999  |                                    |            | 06-03-2013   | RB    | 03                     |                  | 13    | CALL BACK             |            |            |           |
| LAND LINE VALUATION SECTION   |            |                          |                   |             |                  |  |   |                                    |            |  |       |                        |                  |       |                       |            |            |           |
| B   | Use Code   | Description              | Zone              | LA          | Land Units       | Unit Price                             | Size Adj  | AC Disc                            | Site Index | Cond.  | Nbhd. | Nbhd. Adj              | Notes            |       | Location Adjustmen    | Adj Unit P | Land Value |           |
| 1   | 1010       | Single Fam M-0           | RD-               | 3           | 1.000            | AC 176,344.00                          | 1.00000   | 1.0000                             | 5          | 1.00   | WF10  | 26.000                 |                  |       | 1.0000                | 4,584,944  | 4,584,900  |           |
| 1   | 1010       | Single Fam M-0           | RD-               | 3           | 1.270            | AC 14,250.00                           | 1.00000   | 1.0000                             | 0          | 1.00   | WF10  | 26.000                 |                  |       | 1.0000                | 370,500    | 470,500    |           |
| Total Card Land Units   |            |                          |                   |             | 2.27             | AC                                     | Parcel Total Land Area  |                                    |            |  |       | 2.27                   | Total Land Value |       |                       |            |            | 5,055,400 |

| CONSTRUCTION DETAIL |    |                | CONSTRUCTION DETAIL (CONTINUED) |    |             |
|---------------------|----|----------------|---------------------------------|----|-------------|
| Element             | Cd | Description    | Element                         | Cd | Description |
| Style               | 06 | Conventional   |                                 |    |             |
| Model               | 01 | Residential    |                                 |    |             |
| Grade:              | A+ | Luxury Plus    |                                 |    |             |
| Stories             | 2  | 2 Stories      |                                 |    |             |
| Exterior Wall 1     | 14 | Wood Shingle   |                                 |    |             |
| Exterior Wall 2     |    |                |                                 |    |             |
| RooF Structure      | 03 | Gable/Hip      |                                 |    |             |
| RooF Cover          | 10 | Wood Shingle   |                                 |    |             |
| Interior Wall 1     | 05 | Drywall        |                                 |    |             |
| Interior Wall 2     |    |                |                                 |    |             |
| Interior Floor 1    | 12 | Hardwood       |                                 |    |             |
| Interior Floor 2    | 11 | Ceram Clay Til |                                 |    |             |
| Heat Fuel           | 03 | Gas            |                                 |    |             |
| Heat Type           | 04 | Hot Air        |                                 |    |             |
| AC Type             | 03 | Central        |                                 |    |             |
| Bedrooms            | 06 | 6 Bedrooms     |                                 |    |             |
| Full Baths          | 6  |                |                                 |    |             |
| Half Baths          | 2  |                |                                 |    |             |
| Extra Fixtures      |    |                |                                 |    |             |
| Total Rooms         | 14 | 14 Rooms       |                                 |    |             |
| Bath Style          |    |                |                                 |    |             |
| Kitchen Style       |    |                |                                 |    |             |
| Occupancy           |    |                |                                 |    |             |
| Usrflid 105         |    |                |                                 |    |             |
| Accessory Apt       |    |                |                                 |    |             |
| Foundation Alt      | 01 | Poured Conc.   |                                 |    |             |
| Rms Prts            |    |                |                                 |    |             |
| Bath Split          | 62 | 6 Full-2 Half  |                                 |    |             |

| CONDO DATA  |      |             |         |          |
|-------------|------|-------------|---------|----------|
| Parcel Id   |      | C           |         | Owne 0.0 |
| Adjust Type | Code | Description | Factor% |          |
| Condo Flr   |      |             |         |          |
| Condo Unit  |      |             |         |          |

| COST / MARKET VALUATION  |           |
|--------------------------|-----------|
| Building Value New       | 3,359,866 |
| Year Built               | 1914      |
| Effective Year Built     | 1999      |
| Depreciation Code        | E         |
| Remodel Rating           |           |
| Year Remodeled           |           |
| Depreciation %           | 16        |
| Functional Obsol         | 0         |
| External Obsol           | 0         |
| Trend Factor             | 1         |
| Condition                |           |
| Condition %              |           |
| Percent Good             | 84        |
| RCNLD                    | 2,822,300 |
| Dep % Ovr                |           |
| Dep Ovr Comment          |           |
| Misc Imp Ovr             |           |
| Misc Imp Ovr Comment     |           |
| Cost to Cure Ovr         |           |
| Cost to Cure Ovr Comment |           |

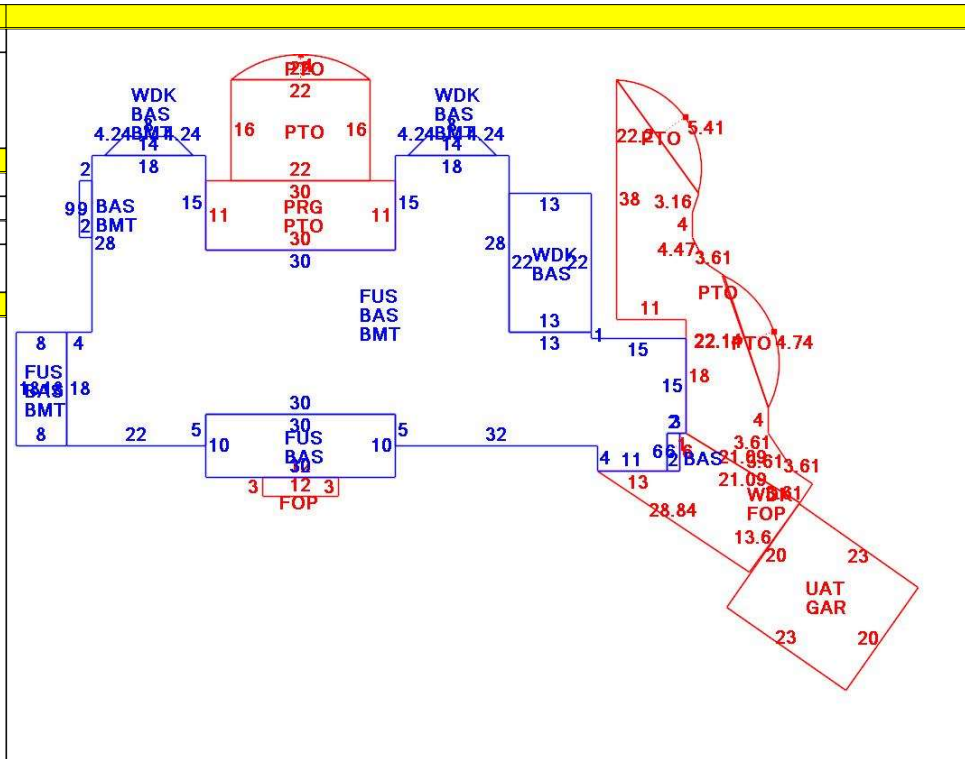

**OB - OUTBUILDING & YARD ITEMS(L) / XF - BUILDING EXTRA FEATURES(B)**

| Code | Description     | L/B | Units | Unit Price | Yr Blt | Cond. Cd | % Gd | Grade | Grade Adj. | Appr. Value |
|------|-----------------|-----|-------|------------|--------|----------|------|-------|------------|-------------|
| FPL3 | Fireplace 2 sto | B   | 2     | 7000.00    | 1999   |          | 84   |       | 0.00       | 11,800      |
| TEN  | Tennis Court 7  | L   | 7,200 | 6.84       | 1999   |          | 60   | 00    | 1.00       | 29,500      |
| SHED | Shed            | L   | 200   | 18.00      | 1986   |          | 34   |       | 0.00       | 1,200       |
| SPL3 | Pool Gunite     | L   | 900   | 75.00      | 1999   |          | 60   | 00    | 1.00       | 39,600      |
| PHS3 | Pool Hs/Good,   | L   | 180   | 180.00     | 2000   |          | 81   | 00    | 1.00       | 26,200      |
| JCZI | Jacuzzi Outsid  | L   | 1     | 9822.00    | 2000   |          | 62   |       | 0.00       | 6,100       |
| GAR4 | Det Gar-w/FU    | L   | 982   | 120.00     | 2007   |          | 88   | A     | 1.58       | 163,800     |
| WDC  | Wood Decking    | L   | 310   | 20.00      | 1986   |          | 34   |       | 0.00       | 2,100       |
| SPH3 | Pool Heater 80  | L   | 1     | 4116.00    | 1999   |          | 60   |       | 0.00       | 2,500       |
| FOP  | Open Porch-ro   | B   | 327   | 55.00      | 1999   |          | 84   |       | 0.00       | 10,800      |

**BUILDING SUB-AREA SUMMARY SECTION**

| Code                       | Description       | Living Area | Floor Area | Eff Area | Unit Cost | Undeprec Value |
|----------------------------|-------------------|-------------|------------|----------|-----------|----------------|
| BAS                        | First Floor       | 3,861       | 3,861      | 3,861    | 454.68    | 1,755,519      |
| BMT                        | Basement Area     | 0           | 3,263      | 0        | 0.00      | 0              |
| FOP                        | Open Porch        | 0           | 327        | 0        | 0.00      | 0              |
| FUS                        | Upper Story       | 3,479       | 3,479      | 3,479    | 454.68    | 1,581,832      |
| GAR                        | Attached Garage   | 0           | 460        | 0        | 0.00      | 0              |
| PRG                        | Pergola           | 0           | 330        | 0        | 0.00      | 0              |
| PTO                        | Patio             | 0           | 1,598      | 0        | 0.00      | 0              |
| UAT                        | Attic, Unfinished | 0           | 460        | 46       | 45.47     | 20,915         |
| WDK                        | Wood Deck         | 0           | 643        | 0        | 0.00      | 0              |
| Ttl Gross Liv / Lease Area |                   | 7,340       | 14,421     | 7,386    |           | 3,358,266      |



| CURRENT OWNER  |            | TOPO        | UTILITIES         | STRT / ROAD      | LOCATION               | CURRENT ASSESSMENT |           |   |            | 801<br>FY2024<br>BARNSTABLE, MA<br><br><b>VISION</b> |           |           |           |      |                    |            |            |  |           |
|--|------------|-------------|-------------------|------------------|------------------------|--------------------|-----------|---|------------|--|-----------|-----------|-----------|------|--------------------|------------|------------|--|-----------|
| CONDON, MARGARET M & CHRIST<br>CONDON 2019 RESIDENCE TRUST<br>343 EL BRILLO<br><br>PALM BEACH FL 33480 |            | 1 Level     | 2 Public Water    | 1 Paved          | 7 Waterfront           | Description        | Code      | Assessed  | Assessed   |  |           |           |           |      |                    |            |            |  |           |
|  |            |             | 4 Gas             |                  | 1 Excel View           | RESIDNTL           | 1010      | 3,276,200   | 3,276,200  |  |           |           |           |      |                    |            |            |  |           |
|  |            |             | 6 Septic          |                  |                        | RES LAND           | 1010      | 5,055,400   | 5,055,400  |  |           |           |           |      |                    |            |            |  |           |
| <b>SUPPLEMENTAL DATA</b>   |            |             |                   |                  |                        | Total              |           |   |            | 8,331,600  | 8,331,600 |           |           |      |                    |            |            |  |           |
| Alt Prcl ID  |            | Split Zonin |                   | Plan Ref. 187/19 |                        |                    |           |   |            |  |           |           |           |      |                    |            |            |  |           |
| BID Parcel   |            | ResExpt Q   |                   | Land Ct#         |                        |                    |           |   |            |  |           |           |           |      |                    |            |            |  |           |
| #DL 1 UNNUM LOT  |            | #DL 2       |                   | #SR              |                        |                    |           |   |            |  |           |           |           |      |                    |            |            |  |           |
| GIS ID F_976450_2694140  |            | Assoc Pid#  |                   | Life Estate      |                        |                    |           |   |            |  |           |           |           |      |                    |            |            |  |           |
| PP STATU   |            |             |                   |                  |                        |                    |           |   |            |  |           |           |           |      |                    |            |            |  |           |
| RECORD OF OWNERSHIP  |            | BK-VOL/PAGE | SALE DATE         | Q/U              | V/I                    | SALE PRIC          | VC        | PREVIOUS ASSESSMENTS (HISTORY)                                      |            |  |           |           |           |      |                    |            |            |  |           |
|  |            |             |                   |                  |                        |                    |           | Year  | Code       | Assessed   | Year      | Code      | Assessed  | Year | Code               | Assessed   |            |  |           |
|  |            |             |                   |                  |                        |                    |           | 2023  | 1010       | 2,819,800  | 2022      | 1010      | 2,373,800 | 2021 | 1010               | 1,655,300  |            |  |           |
|  |            |             |                   |                  |                        |                    |           |   | 1010       | 4,638,600  |           | 1010      | 3,558,000 |      | 1010               | 3,284,300  |            |  |           |
|  |            |             |                   |                  |                        |                    |           |   |            |  |           |           |           |      | 1010               | 355,600    |            |  |           |
|  |            |             |                   |                  |                        |                    |           | Total   |            |  | 7,458,400 |           | Total     |      | 5,931,800          |            | Total      |  | 5,295,200 |
| EXEMPTIONS   |            |             | OTHER ASSESSMENTS |                  |                        |                    |           | This signature acknowledges a visit by a Data Collector or Assessor |            |  |           |           |           |      |                    |            |            |  |           |
| Year   | Code       | Description | Amount            | Code             | Description            | Number             | Amount    | Comm Int  |            |  |           |           |           |      |                    |            |            |  |           |
|  |            |             |                   |                  |                        |                    |           |   |            |  |           |           |           |      |                    |            |            |  |           |
|  |            |             |                   |                  |                        |                    |           |   |            |  |           |           |           |      |                    |            |            |  |           |
|  |            | Total       |                   |                  |                        |                    |           |   |            |  |           |           |           |      |                    |            |            |  |           |
| ASSESSING NEIGHBORHOOD   |            |             |                   |                  |                        |                    |           |   |            | APPRAISED VALUE SUMMARY                              |           |           |           |      |                    |            |            |  |           |
| Nbhd   |            | Nbhd Name   |                   | B                |                        | Tracing            |           | Batch   |            | Appraised Bldg. Value (Card)                         |           |           |           |      |                    | 2,822,300  |            |  |           |
| WF10   |            |             |                   |                  |                        |                    |           | CENVIL  |            | Appraised Xf (B) Value (Bldg)                        |           |           |           |      |                    | 98,300     |            |  |           |
|  |            |             |                   |                  |                        |                    |           |   |            | Appraised Ob (B) Value (Bldg)                        |           |           |           |      |                    | 355,600    |            |  |           |
|  |            |             |                   |                  |                        |                    |           |   |            | Appraised Land Value (Bldg)                          |           |           |           |      |                    | 5,055,400  |            |  |           |
|  |            |             |                   |                  |                        |                    |           |   |            | Special Land Value                                   |           |           |           |      |                    | 0          |            |  |           |
|  |            |             |                   |                  |                        |                    |           |   |            | Total Appraised Parcel Value                         |           |           |           |      |                    | 8,331,600  |            |  |           |
|  |            |             |                   |                  |                        |                    |           |   |            | Valuation Method                                     |           |           |           |      |                    | C          |            |  |           |
|  |            |             |                   |                  |                        |                    |           |   |            | Total Appraised Parcel Value                         |           |           |           |      |                    | 8,331,600  |            |  |           |
| BUILDING PERMIT RECORD   |            |             |                   |                  |                        |                    |           |   |            | VISIT / CHANGE HISTORY                               |           |           |           |      |                    |            |            |  |           |
| Permit Id  | Issue Date | Type        | Description       | Amount           | Insp Date              | % Comp             | Date Comp | Comments  |            | Date   | Id        | Type      | Is        | Cd   | Purpost/Result     |            |            |  |           |
|  |            |             |                   |                  |                        |                    |           |   |            |  |           |           |           |      |                    |            |            |  |           |
|  |            |             |                   |                  |                        |                    |           |   |            |  |           |           |           |      |                    |            |            |  |           |
|  |            |             |                   |                  |                        |                    |           |   |            |  |           |           |           |      |                    |            |            |  |           |
|  |            |             |                   |                  |                        |                    |           |   |            |  |           |           |           |      |                    |            |            |  |           |
|  |            |             |                   |                  |                        |                    |           |   |            |  |           |           |           |      |                    |            |            |  |           |
|  |            |             |                   |                  |                        |                    |           |   |            |  |           |           |           |      |                    |            |            |  |           |
| LAND LINE VALUATION SECTION  |            |             |                   |                  |                        |                    |           |   |            |  |           |           |           |      |                    |            |            |  |           |
| B  | Use Code   | Description | Zone              | LA               | Land Units             | Unit Price         | Size Adj  | AC Disc   | Site Index | Cond.  | Nbhd.     | Nbhd. Adj | Notes     |      | Location Adjustmen | Adj Unit P | Land Value |  |           |
|  |            |             |                   |                  |                        |                    |           |   |            |  |           |           |           |      |                    |            |            |  |           |
| Total Card Land Units  |            |             |                   |                  | Parcel Total Land Area |                    |           |   |            | Total Land Value                                     |           |           |           |      |                    |            |            |  |           |

| CONSTRUCTION DETAIL   |                 |                |            |            |           | CONSTRUCTION DETAIL (CONTINUED) |      |             |            |             |     |
|---|-----------------|----------------|------------|------------|-----------|---------------------------------|------|-------------|------------|-------------|-----|
| Element   | Cd              | Description    |            |            |           | Element                         | Cd   | Description |            |             |     |
| Style   | 06              | Conventional   |            |            |           |                                 |      |             |            |             |     |
| Model   | 01              | Residential    |            |            |           |                                 |      |             |            |             |     |
| Grade:  | A+              | Luxury Plus    |            |            |           |                                 |      |             |            |             |     |
| Stories   | 2               | 2 Stories      |            |            |           |                                 |      |             |            |             |     |
| Exterior Wall 1   | 14              | Wood Shingle   |            |            |           | <b>CONDO DATA</b>               |      |             |            |             |     |
| Exterior Wall 2   |                 |                |            |            |           | Parcel Id                       |      | C           |            | Owne        | 0.0 |
| Roof Structure  | 03              | Gable/Hip      |            |            |           |                                 |      | B           |            | S           |     |
| Roof Cover  | 10              | Wood Shingle   |            |            |           | Adjust Type                     | Code | Description | Factor%    |             |     |
| Interior Wall 1   | 05              | Drywall        |            |            |           | Condo Flr                       |      |             |            |             |     |
| Interior Wall 2   |                 |                |            |            |           | Condo Unit                      |      |             |            |             |     |
| Interior Floor 1  | 12              | Hardwood       |            |            |           | <b>COST / MARKET VALUATION</b>  |      |             |            |             |     |
| Interior Floor 2  | 11              | Ceram Clay Til |            |            |           | Building Value New              |      |             |            |             |     |
| Heat Fuel   | 03              | Gas            |            |            |           | Year Built                      |      |             |            |             |     |
| Heat Type   | 04              | Hot Air        |            |            |           | Effective Year Built            |      |             |            |             |     |
| AC Type   | 03              | Central        |            |            |           | Depreciation Code               |      |             |            |             |     |
| Bedrooms  | 06              | 6 Bedrooms     |            |            |           | Remodel Rating                  |      |             |            |             |     |
| Full Baths  | 6               |                |            |            |           | Year Remodeled                  |      |             |            |             |     |
| Half Baths  | 2               |                |            |            |           | Depreciation %                  |      |             |            |             |     |
| Extra Fixtures  |                 |                |            |            |           | Functional Obsol                |      |             |            |             |     |
| Total Rooms   | 14              | 14 Rooms       |            |            |           | External Obsol                  |      |             |            |             |     |
| Bath Style  |                 |                |            |            |           | Trend Factor                    |      |             |            |             |     |
| Kitchen Style   |                 |                |            |            |           | Condition                       |      |             |            |             |     |
| Occupancy   |                 |                |            |            |           | Condition %                     |      |             |            |             |     |
| Usrflid 105   |                 |                |            |            |           | Percent Good                    |      |             |            |             |     |
| Accessory Apt   |                 |                |            |            |           | RCNLD                           |      |             |            |             |     |
| Foundation Alt  | 01              | Poured Conc.   |            |            |           | Dep % Ovr                       |      |             |            |             |     |
| Rms Prts  |                 |                |            |            |           | Dep Ovr Comment                 |      |             |            |             |     |
| Bath Split  | 62              | 6 Full-2 Half  |            |            |           | Misc Imp Ovr                    |      |             |            |             |     |
|   |                 |                |            |            |           | Misc Imp Ovr Comment            |      |             |            |             |     |
|   |                 |                |            |            |           | Cost to Cure Ovr                |      |             |            |             |     |
|   |                 |                |            |            |           | Cost to Cure Ovr Comment        |      |             |            |             |     |
| <b>OB - OUTBUILDING &amp; YARD ITEMS(L) / XF - BUILDING EXTRA FEATURES(B)</b> |                 |                |            |            |           |                                 |      |             |            |             |     |
| Code  | Description     | L/B            | Units      | Unit Price | Yr Blt    | Cond. Cd                        | % Gd | Grade       | Grade Adj. | Appr. Value |     |
| GAR   | Attached Gara   | B              | 460        | 40.00      | 1999      |                                 | 84   |             | 0.00       | 14,800      |     |
| WDC   | Wood Decking    | L              | 643        | 20.00      | 2012      |                                 | 86   |             | 0.00       | 10,200      |     |
| BMT   | Basement-Unfi   | B              | 3,263      | 26.01      | 1999      |                                 | 84   |             | 0.00       | 56,700      |     |
| FPLG  | Gas Fireplace-  | B              | 2          | 2500.00    | 1999      |                                 | 84   |             | 0.00       | 4,200       |     |
| STRS  | Stairs to Water | L              | 9          | 122.52     | 1987      |                                 | 36   | B           | 1.32       | 500         |     |
| FNC5  | FENCE-10'CH     | L              | 360        | 34.35      | 1987      |                                 | 36   |             | 0.00       | 4,500       |     |
| GEN1  | Large Generat   | L              | 1          | 29300.00   | 2012      |                                 | 86   |             | 0.00       | 25,200      |     |
| PATF  | Flagstone Pav   | L              | 1,598      | 30.00      | 2012      |                                 | 93   |             | 0.00       | 37,500      |     |
| PRG1  | Pergola-Avg     | L              | 330        | 18.00      | 2012      |                                 | 86   | B           | 1.32       | 6,700       |     |
| <b>BUILDING SUB-AREA SUMMARY SECTION</b>                                      |                 |                |            |            |           |                                 |      |             |            |             |     |
| Code  | Description     | Living Area    | Floor Area | Eff Area   | Unit Cost | Undeprec Value                  |      |             |            |             |     |
|   |                 |                |            |            |           |                                 |      |             |            |             |     |
| Ttl Gross Liv / Lease Area  |                 |                |            |            |           |                                 |      |             |            |             |     |