

CURRENT OWNER		TOPO	UTILITIES	STRT / ROAD	LOCATION	CURRENT ASSESSMENT			
ODELL, JENNIFER K & HERMSEN, JA NANCY A ODELL IRREV TRUST 19 BALDWIN COURT WESTBOROUG MA 01581	1 Level	2 Public Water	1 Paved	1 Water View	Description	Code	Assessed	Assessed	801 FY2024 BARNSTABLE, MA VISION
		4 Gas		9 Rear Location	RESIDNTL	1010	350,500	350,500	
		6 Septic			RES LAND	1010	1,132,400	1,132,400	
SUPPLEMENTAL DATA									
Alt Prcl ID Split Zonin RD-1;RB BID Parcel ResExpt Q #DL 1 LOT 45 #DL 2 GIS ID F_977852_2693610				Plan Ref. Land Ct# 15694-E #SR Life Estate PP STATU Assoc Pid#		Total 1,482,900 1,482,900			

RECORD OF OWNERSHIP		BK-VOL/PAGE	SALE DATE	Q/U	V/I	SALE PRIC	VC	PREVIOUS ASSESSMENTS (HISTORY)									
ODELL, JENNIFER K & HERMSEN, JACQ	C191747	0	06-22-2010	U	I	100	1A	Year	Code	Assessed	Year	Code	Assessed				
ODELL, NANCY A	C154892	0	09-24-1999	U	I	100	1A	2023	1010	301,500	2022	1010	256,300				
ODELL, JOHN A & NANCY A	C94405	0	11-15-1983	Q	I	190,000	U		1010	1,029,500	2021	1010	557,300				
Total								1,331,000		Total		813,600		Total		744,900	

EXEMPTIONS				OTHER ASSESSMENTS			
Year	Code	Description	Amount	Code	Description	Number	Amount
Total			0.00				

ASSESSING NEIGHBORHOOD			
Nbhd	Nbhd Name	B	Tracing
0114			CENVIL

NOTES			

BUILDING PERMIT RECORD								VISIT / CHANGE HISTORY						
Permit Id	Issue Date	Type	Description	Amount	Insp Date	% Comp	Date Comp	Comments	Date	Id	Type	Is	Cd	Purpost/Result
201001598	04-09-2010	NR	New Roof	15,000	06-30-2010	100	06-30-2010	REROOF PATCHING-RESIDE	05-20-2020	WD			FR	Field Review
61375	05-14-2002	OB	Out Building		09-30-2002	100	01-01-2003		11-19-2013	RB	03		16	In Office Review
									09-09-2013	RB	03		03	Cycl Insp Comp
									03-10-2010	PT	02		14	Cyclical Inspection
									07-30-2003	PT	02		01	Meas/Est
									09-30-2002	MF	02		02	Bldg Permit Completed
								08-21-2001	PT	01		00	Meas/Listed-Interior Acces	

LAND LINE VALUATION SECTION																	
B	Use Code	Description	Zone	LA	Land Units	Unit Price	Size Adj	AC Disc	Site Index	Cond.	Nbhd.	Nbhd. Adj	Notes	Location Adjustmen	Adj Unit P	Land Value	
1	1010	Single Fam M-0	SPLI	3	0.870	AC	176,344.00	1.13555	1.0000	5	1.00	0114	6.500		1.0000	1,301,612	1,132,400
Total Card Land Units					0.87	AC	Parcel Total Land Area					0.87	Total Land Value				1,132,400

CONSTRUCTION DETAIL			CONSTRUCTION DETAIL (CONTINUED)		
Element	Cd	Description	Element	Cd	Description
Style	01	Ranch			
Model	01	Residential			
Grade:	C	Average			
Stories	1	1 Story			
Exterior Wall 1	14	Wood Shingle			
Exterior Wall 2	25	Vinyl Siding			
Roof Structure	03	Gable/Hip			
Roof Cover	03	Asph/F Gls/Cmp			
Interior Wall 1	03	Plastered			
Interior Wall 2					
Interior Floor 1	20	Typical			
Interior Floor 2	14	Carpet			
Heat Fuel	03	Gas			
Heat Type	04	Hot Air			
AC Type	03	Central			
Bedrooms	03	3 Bedrooms			
Full Baths	3				
Half Baths	0				
Extra Fixtures					
Total Rooms	6	6 Rooms			
Bath Style					
Kitchen Style					
Occupancy					
Usrflid 105					
Accessory Apt					
Foundation Alt	09	Blk/Pour Ftgs			
Rms Prts					
Bath Split	30	3 Full-0 Half			
			CONDO DATA		
Parcel Id			C	Owne	0.0
Adjust Type		Code	Description	Factor%	
Condo Flr					
Condo Unit					
			COST / MARKET VALUATION		
Building Value New				431,340	
Year Built				1969	
Effective Year Built				1990	
Depreciation Code				A	
Remodel Rating					
Year Remodeled					
Depreciation %				23	
Functional Obsol				0	
External Obsol				0	
Trend Factor				1	
Condition					
Condition %					
Percent Good				77	
RCNLD				332,100	
Dep % Ovr					
Dep Ovr Comment					
Misc Imp Ovr					
Misc Imp Ovr Comment					
Cost to Cure Ovr					
Cost to Cure Ovr Comment					

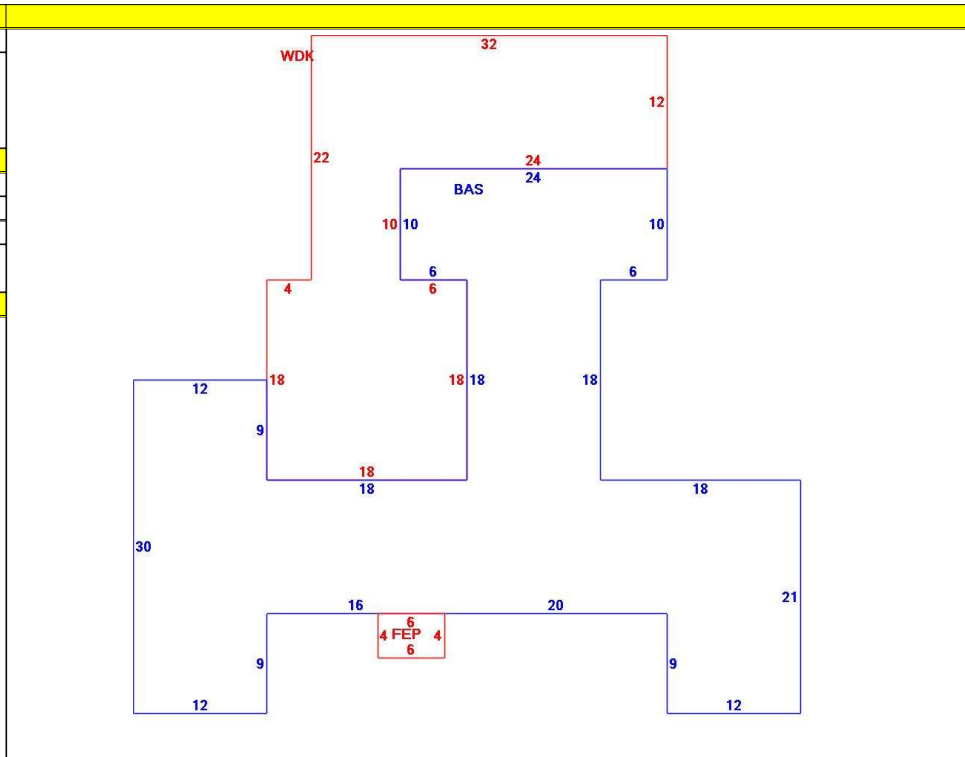

OB - OUTBUILDING & YARD ITEMS(L) / XF - BUILDING EXTRA FEATURES(B)										
Code	Description	L/B	Units	Unit Price	Yr Blt	Cond. Cd	% Gd	Grade	Grade Adj.	Appr. Value
FPL1	Fireplace 1 sto	B	1	5000.00	1992		77		0.00	3,900
FPO	Ext FP Openin	B	1	2000.00	1992		77		0.00	1,500
WDC	Wood Decking	L	788	20.00	1995		52		0.00	7,400
FEP	Enclosed porc	B	24	70.00	1992		77		0.00	2,700
SHED	Shed	L	160	18.00	2019		100		0.00	2,900

BUILDING SUB-AREA SUMMARY SECTION						
Code	Description	Living Area	Floor Area	Eff Area	Unit Cost	Undeprec Value
BAS	First Floor	1,500	1,500	1,500	287.56	431,340
FEP	Enclosed Porch	0	24	0	0.00	0
WDC	Wood Deck	0	788	0	0.00	0
Ttl Gross Liv / Lease Area		1,500	2,312	1,500		431,340

