

CURRENT OWNER		TOPO		UTILITIES		STRT / ROAD		LOCATION		CURRENT ASSESSMENT				801 FY2024 BARNSTABLE, MA  <b>VISION</b>					
TOBIN, JOHN E & GLENN & SHEILA  PO BOX 404  WEST HYANNIS MA 02672		1	Level	6	Septic	1	Paved			Description	Code	Assessed	Assessed			RESIDENTL RES LAND	411,500 309,700	411,500 309,700	
		4	Gas																
		2	Public Water																
<b>SUPPLEMENTAL DATA</b>										Total		721,200	721,200						
Alt Prcl ID		Split Zonin		Plan Ref.		34/23													
BID Parcel		ResExpt Q		Land Ct#		#SR													
#DL 1		LOTS 375 & 377		Life Estate		PP STATU													
#DL 2		BLOCK D		Assoc Pid#															
GIS ID		F_978784_2694662																	
RECORD OF OWNERSHIP				BK-VOL/PAGE		SALE DATE		Q/U		V/I		SALE PRIC		VC		PREVIOUS ASSESSMENTS (HISTORY)			
TOBIN, GLENN E & SHEILA L TR				35872	44	06-30-2023	U	I	1	1F	Year	Code	Assessed	Year	Code	Assessed	Year	Code	Assessed
TOBIN, JOHN E & GLENN & SHEILA				35512	203	11-30-2022	Q	I	775,000	00	2023	1010	364,800	2022	1010	300,900	2021	1010	249,100
SERPICO, DANIEL & WALSH, KATHLEEN				12152	0287	03-26-1999	Q	I	168,000	00		1010	287,900		1010	199,100		1010	218,000
ZIVE, FAY				1536	0282	10-01-1971	U		0									1010	3,800
Total										652,700	Total	500,000	Total	470,900					
EXEMPTIONS				OTHER ASSESSMENTS				This signature acknowledges a visit by a Data Collector or Assessor											
Year	Code	Description		Amount		Code	Description	Number	Amount	Comm Int									
Total				0.00								<b>APPRAISED VALUE SUMMARY</b>							
Nbhd				Nbhd Name		B		Tracing		Batch		Appraised Bldg. Value (Card) 397,200							
0109								HYAN		Appraised Xf (B) Value (Bldg) 10,500									
<b>NOTES</b>												Appraised Ob (B) Value (Bldg) 3,800							
												Appraised Land Value (Bldg) 309,700							
												Special Land Value 0							
												Total Appraised Parcel Value 721,200							
												Valuation Method C							
												Total Appraised Parcel Value 721,200							
BUILDING PERMIT RECORD										VISIT / CHANGE HISTORY									
Permit Id	Issue Date	Type	Description	Amount	Insp Date	% Comp	Date Comp	Comments		Date	Id	Type	Is	Cd	Purpost/Result				
EXPR-21-1	12-14-2021	835	Sid/Wind/Roof/	12,000	06-30-2022	100	06-30-2022	Weatherization		05-26-2023	TR	02		20	Sale Review				
201307800	10-30-2013	RA	Remodel-Additi	200,000	08-15-2014	100	06-30-2015	RA ENLARGE KIT-NW LAUN		04-21-2023	AG	22		22	Change of Address				
B29871	09-02-1986	AD	Addition	15,000	01-15-1987	100	01-15-1987	HP REMOD'		05-20-2020	WD			FR	Field Review				
B29871A	09-01-1986	AD	Addition	15,000	01-15-1988	100	01-15-1988	HP REMOD'		11-26-2014	MW	01		02	Bldg Permit Completed				
										09-08-2014	SR	02		03	Cycl Insp Comp				
										06-23-2014	MW	01		13	CALL BACK				
LAND LINE VALUATION SECTION																			
B	Use Code	Description	Zone	LA	Land Units	Unit Price	Size Adj	AC Disc	Site Index	Cond.	Nbhd.	Nbhd. Adj	Notes	Location Adjustmen	Adj Unit P	Land Value			
1	1010	Single Fam M-0	RB	4	0.180	AC	176,344.00	4.43465	1.0000	5	1.00	0109	2.200		1.0000	1,720,464	309,700		
Total Card Land Units					0.18	AC	Parcel Total Land Area					0.18	Total Land Value					309,700	

CONSTRUCTION DETAIL			CONSTRUCTION DETAIL (CONTINUED)		
Element	Cd	Description	Element	Cd	Description
Style	04	Cape Cod			
Model	01	Residential			
Grade:	C+	Average Plus			
Stories	1.5	1 1/2 Stories			
Exterior Wall 1	25	Vinyl Siding			
Exterior Wall 2	14	Wood Shingle			
Roof Structure	03	Gable/Hip			
Roof Cover	03	Asph/F Gls/Cmp			
Interior Wall 1	03	Plastered			
Interior Wall 2	05	Drywall			
Interior Floor 1	14	Carpet			
Interior Floor 2					
Heat Fuel	03	Gas			
Heat Type	04	Hot Air			
AC Type	03	Central			
Bedrooms	03	3 Bedrooms			
Full Baths	2				
Half Baths	1				
Extra Fixtures					
Total Rooms	6	6 Rooms			
Bath Style	02	Average			
Kitchen Style	02	Modernized			
Occupancy					
Usrflid 105					
Accessory Apt					
Foundation Alt	09	Blk/Pour Ftgs			
Rms Prts					
Bath Split	21	2 Full-1 Half			

CONDO DATA				
Parcel Id		C	Owne	0.0
Adjust Type	Code	Description	Factor%	
Condo Flr				
Condo Unit				

COST / MARKET VALUATION		
Building Value New		479,740
Year Built		1955
Effective Year Built		1993
Depreciation Code		VG
Remodel Rating		
Year Remodeled		
Depreciation %	20	
Functional Obsol	0	
External Obsol	0	
Trend Factor	1	
Condition		
Condition %		
Percent Good	80	
RCNLD	397,200	
Dep % Ovr		
Dep Ovr Comment		
Misc Imp Ovr		
Misc Imp Ovr Comment		
Cost to Cure Ovr		
Cost to Cure Ovr Comment		

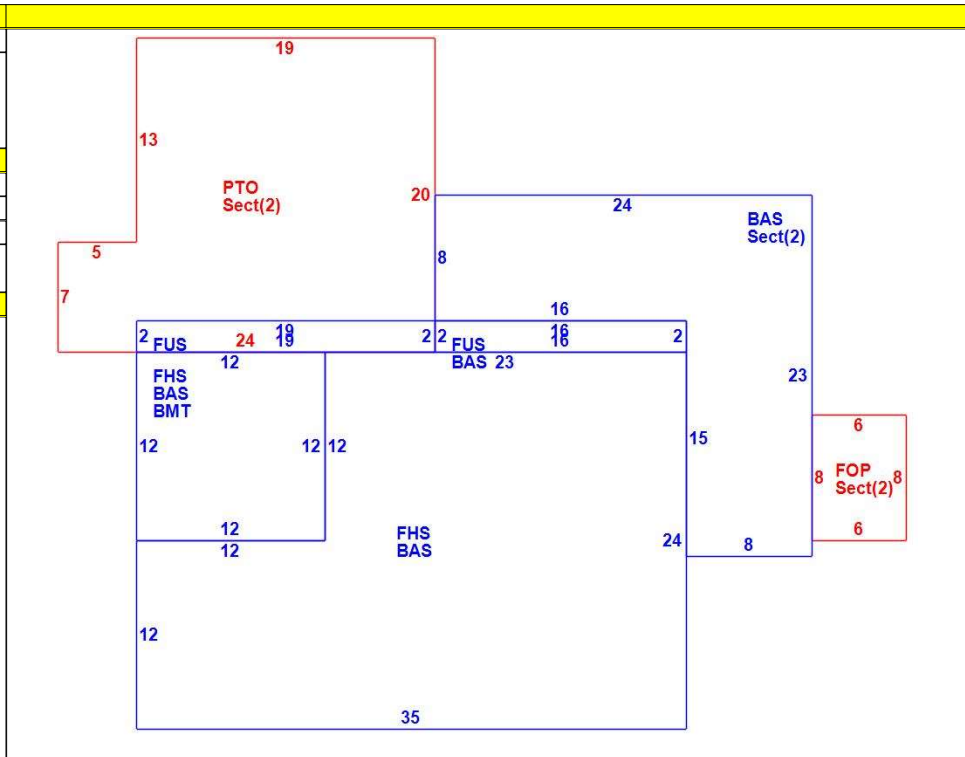

OB - OUTBUILDING & YARD ITEMS(L) / XF - BUILDING EXTRA FEATURES(B)										
Code	Description	L/B	Units	Unit Price	Yr Blt	Cond. Cd	% Gd	Grade	Grade Adj.	Appr. Value
FPLG	Gas Fireplace-	B	1	2500.00	1995		80		0.00	2,000
BMT	Basement-Unfi	B	144	26.01	1995		80		0.00	5,400

BUILDING SUB-AREA SUMMARY SECTION						
Code	Description	Living Area	Floor Area	Eff Area	Unit Cost	Undeprec Value
BAS	First Floor	872	872	872	286.58	249,900
BMT	Basement Area	0	144	0	0.00	0
FHS	Half Story	420	840	420	143.29	120,365
FUS	Upper Story	70	70	70	286.58	20,061
Ttl Gross Liv / Lease Area		1,362	1,926	1,362		390,326



CURRENT OWNER		TOPO		UTILITIES		STRT / ROAD		LOCATION		CURRENT ASSESSMENT			
TOBIN, JOHN E & GLENN & SHEILA  PO BOX 404  WEST HYANNIS MA 02672		1	Level	6	Septic	1	Paved			Description	Code	Assessed	Assessed
				4	Gas					RESIDENTL	1010	411,500	411,500
				2	Public Water					RES LAND	1010	309,700	309,700
<b>SUPPLEMENTAL DATA</b>										Total		721,200	721,200
Alt Prcl ID Split Zonin BID Parcel ResExpt Q #DL 1 LOTS 375 & 377 #DL 2 BLOCK D GIS ID F_978784_2694662				Plan Ref. 34/23 Land Ct# #SR Life Estate PP STATU Assoc Pid#									

801  
 FY2024  
 BARNSTABLE, MA  
**VISION**

RECORD OF OWNERSHIP		BK-VOL/PAGE		SALE DATE		Q/U		V/I		SALE PRIC		VC		PREVIOUS ASSESSMENTS (HISTORY)						
TOBIN, GLENN E & SHEILA L TR		35872	44	06-30-2023		U	I			1	1F	Year	Code	Assessed	Year	Code	Assessed	Year	Code	Assessed
TOBIN, JOHN E & GLENN & SHEILA		35512	203	11-30-2022		Q	I			775,000	00	2023	1010	364,800	2022	1010	300,900	2021	1010	249,100
SERPICO, DANIEL & WALSH, KATHLEEN		12152	0287	03-26-1999		Q	I			168,000	00		1010	287,900		1010	199,100		1010	218,000
ZIVE, FAY		1536	0282	10-01-1971		U				0									1010	3,800
Total												652,700	Total	500,000	Total	470,900				

EXEMPTIONS				OTHER ASSESSMENTS				This signature acknowledges a visit by a Data Collector or Assessor											
Year	Code	Description	Amount	Code	Description	Number	Amount												
Total			0.00																

ASSESSING NEIGHBORHOOD				APPRAISED VALUE SUMMARY								
Nbhd	Nbhd Name		B	Tracing		Batch		Appraised Bldg. Value (Card)				397,200
0109						HYAN		Appraised Xf (B) Value (Bldg)				10,500
								Appraised Ob (B) Value (Bldg)				3,800
								Appraised Land Value (Bldg)				309,700
								Special Land Value				0
								Total Appraised Parcel Value				721,200
								Valuation Method				C
								Total Appraised Parcel Value				721,200

NOTES										VISIT / CHANGE HISTORY									
										Date	Id	Type	Is	Cd	Purpost/Result				
										05-26-2023	TR	02		20	Sale Review				
										04-21-2023	AG	22		22	Change of Address				
										05-20-2020	WD			FR	Field Review				
										11-26-2014	MW	01		02	Bldg Permit Completed				
										09-08-2014	SR	02		03	Cycl Insp Comp				
										06-23-2014	MW	01		13	CALL BACK				

BUILDING PERMIT RECORD										LAND LINE VALUATION SECTION									
Permit Id	Issue Date	Type	Description	Amount	Insp Date	% Comp	Date Comp	Comments		Date	Id	Type	Is	Cd	Purpost/Result				
EXPR-21-1	12-14-2021	835	Sid/Wind/Roof/	12,000	06-30-2022	100	06-30-2022	Weatherization		05-26-2023	TR	02		20	Sale Review				
201307800	10-30-2013	RA	Remodel-Additi	200,000	08-15-2014	100	06-30-2015	RA ENLARGE KIT-NW LAUN		04-21-2023	AG	22		22	Change of Address				
B29871	09-02-1986	AD	Addition	15,000	01-15-1987	100	01-15-1987	HP REMOD'		05-20-2020	WD			FR	Field Review				
B29871A	09-01-1986	AD	Addition	15,000	01-15-1988	100	01-15-1988	HP REMOD'		11-26-2014	MW	01		02	Bldg Permit Completed				
										09-08-2014	SR	02		03	Cycl Insp Comp				
										06-23-2014	MW	01		13	CALL BACK				

B	Use Code	Description	Zone	LA	Land Units	Unit Price	Size Adj	AC Disc	Site Index	Cond.	Nbhd.	Nbhd. Adj	Notes	Location Adjustmen	Adj Unit P	Land Value		
1	1010	Single Fam M-0	RB	4	0.180	AC	176,344.00	4.43465	1.0000	5	1.00	0109	2.200		1.0000	1,720,464	309,700	
Total Card Land Units					0.18	AC	Parcel Total Land Area					0.18	Total Land Value					309,700

