

| CURRENT OWNER  |  | TOPO              | UTILITIES      | STRT / ROAD             | LOCATION | CURRENT ASSESSMENT |      |           |           | 801<br>FY2024<br>BARNSTABLE, MA<br><br><b>VISION</b> |           |
|--|--|-------------------|----------------|-------------------------|----------|--------------------|------|-----------|-----------|--|-----------|
| SCHINDLER, JERALD S<br><br>PO BOX 394<br><br>WEST HYANNIS MA 02672 |  | 1 Level           | 2 Public Water | 1 Paved                 |          | Description        | Code | Assessed  | Assessed  |  |           |
|  |  |                   | 4 Gas          |                         |          | RESIDNTL           | 1010 | 2,281,600 | 2,281,600 |  |           |
|  |  |                   | 6 Septic       |                         |          | RES LAND           | 1010 | 1,120,700 | 1,120,700 |  |           |
| <b>SUPPLEMENTAL DATA</b>   |  |                   |                |                         |          | Total              |      |           |           | 3,402,300  | 3,402,300 |
| Alt Prcl ID  |  | Split Zonin       |                | Plan Ref.               |          |                    |      |           |           |  |           |
| BID Parcel   |  | ResExpt Q NO APP: |                | Land Ct# 15694-D (SH 2) |          |                    |      |           |           |  |           |
| #DL 1 LOT 15   |  | #DL 2             |                | Life Estate             |          |                    |      |           |           |  |           |
| GIS ID F_977537_2694768  |  | Assoc Pid#        |                | PP STATU A:Active       |          |                    |      |           |           |  |           |

| RECORD OF OWNERSHIP                |  | BK-VOL/PAGE | SALE DATE | Q/U        | V/I | SALE PRIC | VC        | PREVIOUS ASSESSMENTS (HISTORY) |       |      |           |       |      |            |       |      |           |
|------------------------------------|--|-------------|-----------|------------|-----|-----------|-----------|--------------------------------|-------|------|-----------|-------|------|------------|-------|------|-----------|
| SCHINDLER, JERALD S                |  | C229943     | 0         | 05-13-2022 | Q   | I         | 3,600,000 | 00                             | Year  | Code | Assessed  | Year  | Code | Assessed V | Year  | Code | Assessed  |
| GIBBONS, ERIN N & TRUEX, DONNA M T |  | C224065     | 0         | 10-15-2020 | Q   | I         | 1,200,000 | 00                             | 2023  | 1010 | 1,010,000 | 2022  | 1010 | 731,900    | 2021  | 1010 | 538,400   |
| MARTONE, MARIE E TR                |  | C214852     | 0         | 12-05-2017 | U   | I         | 1         | 1F                             |       | 1010 | 1,018,800 |       | 1010 | 551,500    |       | 1010 | 534,100   |
| MARTONE, MARIE E TR                |  | D133591     | 0         | 02-26-2017 | U   | I         | 0         | 1F                             |       |      |           |       |      |            |       | 1010 | 29,500    |
| MARTONE, THOMAS A & MARIE E        |  | C193851     | 0         | 03-21-2011 | U   | I         | 1         | 1A                             | Total |      | 2,028,800 | Total |      | 1,283,400  | Total |      | 1,102,000 |

| EXEMPTIONS |      |                          |        | OTHER ASSESSMENTS |             |        |        | This signature acknowledges a visit by a Data Collector or Assessor |  |  |  |  |  |  |  |  |  |  |
|------------|------|--------------------------|--------|-------------------|-------------|--------|--------|---|--|--|--|--|--|--|--|--|--|--|
| Year       | Code | Description              | Amount | Code              | Description | Number | Amount | Comm Int  |  |  |  |  |  |  |  |  |  |  |
| 2022       | N5C  | NO RESIDENTIAL EXEMPTION | 0.00   |                   |             |        |        |   |  |  |  |  |  |  |  |  |  |  |
| Total      |      |                          | 0.00   |                   |             |        |        |   |  |  |  |  |  |  |  |  |  |  |

| ASSESSING NEIGHBORHOOD |           |   |         | APPRAISED VALUE SUMMARY       |           |  |  |  |  |
|------------------------|-----------|---|---------|-------------------------------|-----------|--|--|--|--|
| Nbhd                   | Nbhd Name | B | Tracing | Batch                         |           |  |  |  |  |
| 0114                   |           |   |         | CENVIL                        |           |  |  |  |  |
| NOTES                  |           |   |         | Appraised Bldg. Value (Card)  | 2,014,600 |  |  |  |  |
|                        |           |   |         | Appraised Xf (B) Value (Bldg) | 95,100    |  |  |  |  |
|                        |           |   |         | Appraised Ob (B) Value (Bldg) | 171,900   |  |  |  |  |
|                        |           |   |         | Appraised Land Value (Bldg)   | 1,120,700 |  |  |  |  |
|                        |           |   |         | Special Land Value            | 0         |  |  |  |  |
|                        |           |   |         | Total Appraised Parcel Value  | 3,402,300 |  |  |  |  |
|                        |           |   |         | Valuation Method              | C         |  |  |  |  |
|                        |           |   |         | Total Appraised Parcel Value  | 3,402,300 |  |  |  |  |

| BUILDING PERMIT RECORD |            |      |                 |         |            |        |            |                                  | VISIT / CHANGE HISTORY |    |      |    |    |                       |
|------------------------|------------|------|-----------------|---------|------------|--------|------------|----------------------------------|------------------------|----|------|----|----|-----------------------|
| Permit Id              | Issue Date | Type | Description     | Amount  | Insp Date  | % Comp | Date Comp  | Comments                         | Date                   | Id | Type | Is | Cd | Purpost/Result        |
| BLDR-21-14             | 02-25-2022 | 882  | Detached Acce   | 40,000  | 03-21-2022 | 100    | 06-30-2022 | build pool house off an existing | 08-28-2023             | CK | 03   |    | 16 | In Office Review      |
| SM-21-89               | 07-13-2021 | 834  | Sheet Metal     | 50,000  | 06-30-2022 | 100    | 06-30-2022 | We are installing a new HVAC     | 09-29-2022             | SR | 02   |    | 03 | Cycl Insp Comp        |
| BLDR-21-51             | 05-11-2021 | 882  | Detached Acce   | 30,000  | 03-21-2022 | 100    | 06-30-2022 | Construct 12'x9' Pool Cabana     | 07-13-2022             | BM | 22   |    | 22 | Change of Address     |
| BLDR-20-36             | 01-12-2021 | 804  | Addn Alt-Res    | 190,000 | 03-21-2022 | 100    | 06-30-2022 | Remodel including, new windo     | 07-13-2022             | BM | 03   |    | 16 | In Office Review      |
| BLDR-21-6              | 01-05-2021 | 830  | Pool - Inground | 99,200  | 03-21-2022 | 100    | 06-30-2022 | Installation of 18x36 inground   | 03-21-2022             | CK | 01   |    | 02 | Bldg Permit Completed |
| 201201150              | 03-05-2012 | IN   | Insulation      | 1,500   |            | 100    |            | INSULATE                         | 08-02-2021             | BM | 22   |    | 22 | Change of Address     |
| B29446                 | 06-01-1986 | SP   | Swimming Pool   | 10,000  | 01-15-1987 | 100    |            | HP SW,POO                        | 05-24-2021             | SR | 02   |    | 13 | CALL BACK             |

| LAND LINE VALUATION SECTION |          |                |      |    |            |            |                        |         |            |       |       |           |                  |                    |            |            |           |
|-----------------------------|----------|----------------|------|----|------------|------------|------------------------|---------|------------|-------|-------|-----------|------------------|--------------------|------------|------------|-----------|
| B                           | Use Code | Description    | Zone | LA | Land Units | Unit Price | Size Adj               | AC Disc | Site Index | Cond. | Nbhd. | Nbhd. Adj | Notes            | Location Adjustmen | Adj Unit P | Land Value |           |
| 1                           | 1010     | Single Fam M-0 | RD-  | 3  | 0.760      | AC         | 176,344.00             | 1.28647 | 1.0000     | 5     | 1.00  | 0114      | 6.500            |                    | 1.0000     | 1,474,606  | 1,120,700 |
| Total Card Land Units       |          |                |      |    | 0.76       | AC         | Parcel Total Land Area |         |            |       |       | 0.76      | Total Land Value |                    |            | 1,120,700  |           |

| CONSTRUCTION DETAIL |    |                | CONSTRUCTION DETAIL (CONTINUED)   |    |             |
|---------------------|----|----------------|---|----|-------------|
| Element             | Cd | Description    | Element   | Cd | Description |
| Style               | 03 | Colonial       |   |    |             |
| Model               | 01 | Residential    |   |    |             |
| Grade:              | X+ | Exceptional PI |   |    |             |
| Stories             | 2  | 2 Stories      |   |    |             |
| Exterior Wall 1     | 14 | Wood Shingle   |   |    |             |
| Exterior Wall 2     |    |                |   |    |             |
| RooF Structure      | 03 | Gable/Hip      |   |    |             |
| RooF Cover          | 03 | Asph/F Gls/Cmp |   |    |             |
| Interior Wall 1     | 05 | Drywall        |   |    |             |
| Interior Wall 2     |    |                |   |    |             |
| Interior Floor 1    | 12 | Hardwood       |   |    |             |
| Interior Floor 2    | 14 | Carpet         |   |    |             |
| Heat Fuel           | 03 | Gas            |   |    |             |
| Heat Type           | 04 | Hot Air        |   |    |             |
| AC Type             | 03 | Central        |   |    |             |
| Bedrooms            | 05 | 5 Bedrooms     |   |    |             |
| Full Baths          | 4  |                |   |    |             |
| Half Baths          | 1  |                |   |    |             |
| Extra Fixtures      |    |                |   |    |             |
| Total Rooms         | 10 | 10 Rooms       |   |    |             |
| Bath Style          |    |                |   |    |             |
| Kitchen Style       |    |                |   |    |             |
| Occupancy           |    |                |   |    |             |
| Usrflid 105         |    |                |   |    |             |
| Accessory Apt       |    |                |   |    |             |
| Foundation Alt      | 01 | Poured Conc.   |   |    |             |
| Rms Prts            |    |                |   |    |             |
| Bath Split          | 41 | 4 Full-1 Half  |   |    |             |
|                     |    |                | <b>CONDO DATA</b><br>Parcel Id: C, Ownr: 0.0<br>Adjust Type: Code, Description, Factor%<br>Condo Flr, Condo Unit  |    |             |
|                     |    |                | <b>COST / MARKET VALUATION</b><br>Building Value New: 2,263,648<br>Year Built: 1978<br>Effective Year Built: 2005<br>Depreciation Code: VG<br>Remodel Rating<br>Year Remodeled<br>Depreciation %: 11<br>Functional Obsol: 0<br>External Obsol: 0<br>Trend Factor: 1<br>Condition<br>Condition %: 89<br>Percent Good: 89<br>RCNLD: 2,014,600<br>Dep % Ovr<br>Dep Ovr Comment<br>Misc Imp Ovr<br>Misc Imp Ovr Comment<br>Cost to Cure Ovr<br>Cost to Cure Ovr Comment |    |             |

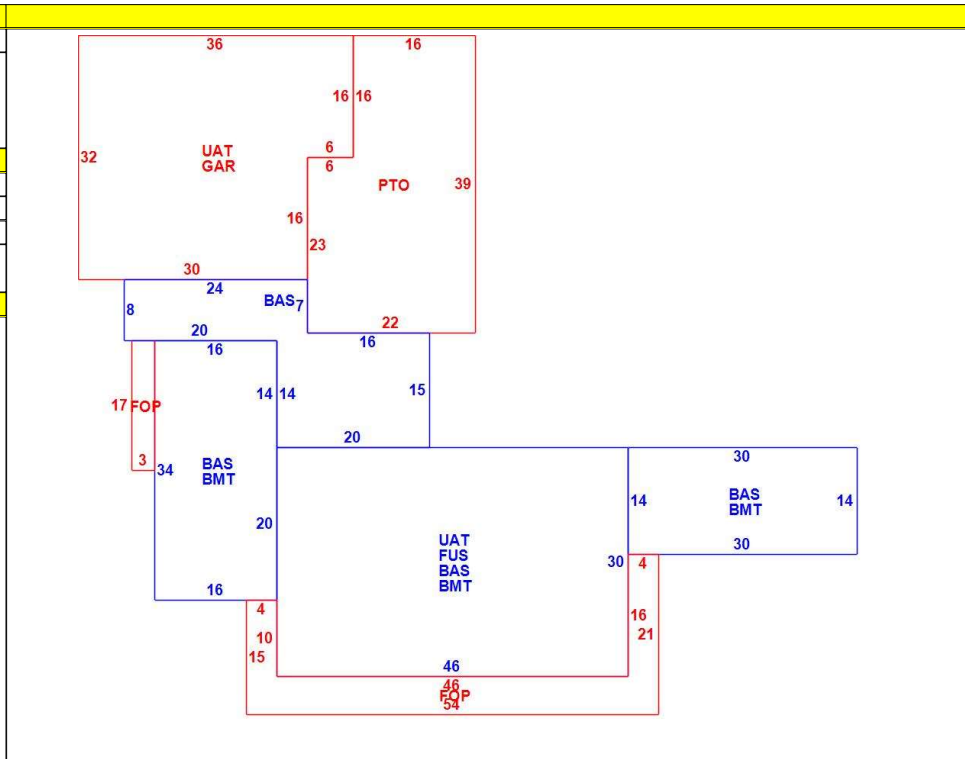

**OB - OUTBUILDING & YARD ITEMS(L) / XF - BUILDING EXTRA FEATURES(B)**

| Code | Description    | L/B | Units | Unit Price | Yr Blt | Cond. Cd | % Gd | Grade | Grade Adj. | Appr. Value |
|------|----------------|-----|-------|------------|--------|----------|------|-------|------------|-------------|
| BRR  | Bsmt Rec Rm-   | B   | 650   | 8.05       | 2007   |          | 89   |       | 0.00       | 4,700       |
| GAR  | Attached Gara  | B   | 1,056 | 40.00      | 2007   |          | 89   |       | 0.00       | 28,900      |
| BMT  | Basement-Unfi  | B   | 2,344 | 26.01      | 2007   |          | 89   |       | 0.00       | 45,000      |
| FOP  | Open Porch-ro  | B   | 425   | 55.00      | 2021   |          | 100  |       | 0.00       | 16,500      |
| SPL3 | Pool Gunite    | L   | 648   | 75.00      | 2021   |          | 100  | A     | 1.58       | 80,600      |
| SPH2 | Pool Heater 50 | L   | 1     | 3081.00    | 2021   |          | 100  |       | 0.00       | 3,100       |
| SPC1 | Pool Cover-Au  | L   | 648   | 17.53      | 2021   |          | 100  |       | 0.00       | 11,400      |
| PHS2 | Pool Hs/Avg.pl | L   | 108   | 120.00     | 2021   |          | 100  | A     | 1.58       | 20,500      |
| FOPD | FOP-CONCR      | L   | 48    | 31.41      | 2021   |          | 100  | A     | 1.58       | 2,900       |
| PATF | Flagstone Pav  | L   | 762   | 30.00      | 2021   |          | 100  |       | 0.00       | 21,300      |

**BUILDING SUB-AREA SUMMARY SECTION**

| Code                       | Description       | Living Area | Floor Area | Eff Area | Unit Cost | Undeprec Value |
|----------------------------|-------------------|-------------|------------|----------|-----------|----------------|
| BAS                        | First Floor       | 2,832       | 2,832      | 2,832    | 508.00    | 1,438,656      |
| BMT                        | Basement Area     | 0           | 2,344      | 0        | 0.00      | 0              |
| FOP                        | Open Porch        | 0           | 425        | 0        | 0.00      | 0              |
| FUS                        | Upper Story       | 1,380       | 1,380      | 1,380    | 508.00    | 701,040        |
| GAR                        | Attached Garage   | 0           | 1,056      | 0        | 0.00      | 0              |
| PTO                        | Patio             | 0           | 762        | 0        | 0.00      | 0              |
| UAT                        | Attic, Unfinished | 0           | 2,436      | 244      | 50.88     | 123,952        |
| Ttl Gross Liv / Lease Area |                   | 4,212       | 11,235     | 4,456    |           | 2,263,648      |



| CURRENT OWNER  |   | TOPO        | UTILITIES | STRT / ROAD      | LOCATION | CURRENT ASSESSMENT |             |                |           | 801<br>FY2024<br>BARNSTABLE, MA<br><br><b>VISION</b> |           |
|--|---|-------------|-----------|------------------|----------|--------------------|-------------|----------------|-----------|--|-----------|
| SCHINDLER, JERALD S<br><br>PO BOX 394<br><br>WEST HYANNIS MA 02672 | 1 | Level       | 2         | Public Water     | 1        | Paved              | Description | Code           | Assessed  |  | Assessed  |
|  |   |             | 4         | Gas              |          |                    | RESIDNTL    | 1010           | 2,281,600 |  | 2,281,600 |
|  |   |             | 6         | Septic           |          |                    | RES LAND    | 1010           | 1,120,700 |  | 1,120,700 |
| <b>SUPPLEMENTAL DATA</b>   |   |             |           |                  |          | Total              |             | 3,402,300      | 3,402,300 |  |           |
| Alt Prcl ID  |   | Split Zonin |           | Plan Ref.        |          | Land Ct#           |             | 15694-D (SH 2) |           |  |           |
| BID Parcel   |   | ResExpt Q   |           | NO APP:          |          | #DL 1              |             | LOT 15         |           |  |           |
| #DL 2  |   | GIS ID      |           | F_977537_2694768 |          | Assoc Pid#         |             |                |           |  |           |

| RECORD OF OWNERSHIP |      | BK-VOL/PAGE | SALE DATE | Q/U  | V/I        | SALE PRIC | VC   | PREVIOUS ASSESSMENTS (HISTORY) |      |      |          |
|---------------------|------|-------------|-----------|------|------------|-----------|------|--------------------------------|------|------|----------|
| Year                | Code | Assessed    | Year      | Code | Assessed V | Year      | Code | Assessed                       | Year | Code | Assessed |
| 2023                | 1010 | 1,010,000   | 2022      | 1010 | 731,900    | 2021      | 1010 | 538,400                        |      |      |          |
|                     | 1010 | 1,018,800   |           | 1010 | 551,500    |           | 1010 | 534,100                        |      |      |          |
|                     |      |             |           |      |            |           | 1010 | 29,500                         |      |      |          |
| Total               |      | 2,028,800   | Total     |      | 1,283,400  | Total     |      | 1,102,000                      |      |      |          |

| EXEMPTIONS |      |             | OTHER ASSESSMENTS |      |             |        | This signature acknowledges a visit by a Data Collector or Assessor |          |  |  |  |
|------------|------|-------------|-------------------|------|-------------|--------|---|----------|--|--|--|
| Year       | Code | Description | Amount            | Code | Description | Number | Amount  | Comm Int |  |  |  |
| Total      |      |             |                   |      |             |        |   |          |  |  |  |

| ASSESSING NEIGHBORHOOD |           |   |         |        |
|------------------------|-----------|---|---------|--------|
| Nbhd                   | Nbhd Name | B | Tracing | Batch  |
| 0114                   |           |   |         | CENVIL |

| NOTES |  |  |  |
|-------|--|--|--|
|       |  |  |  |

| BUILDING PERMIT RECORD |            |      |             |        |           | VISIT / CHANGE HISTORY |           |          |      |    |      |    |    |                |
|------------------------|------------|------|-------------|--------|-----------|------------------------|-----------|----------|------|----|------|----|----|----------------|
| Permit Id              | Issue Date | Type | Description | Amount | Insp Date | % Comp                 | Date Comp | Comments | Date | Id | Type | Is | Cd | Purpost/Result |
|                        |            |      |             |        |           |                        |           |          |      |    |      |    |    |                |

| LAND LINE VALUATION SECTION |          |             |      |    |                        |            |          |         |            |                  |       |           |       |                    |            |            |
|-----------------------------|----------|-------------|------|----|------------------------|------------|----------|---------|------------|------------------|-------|-----------|-------|--------------------|------------|------------|
| B                           | Use Code | Description | Zone | LA | Land Units             | Unit Price | Size Adj | AC Disc | Site Index | Cond.            | Nbhd. | Nbhd. Adj | Notes | Location Adjustmen | Adj Unit P | Land Value |
|                             |          |             |      |    |                        |            |          |         |            |                  |       |           |       |                    |            |            |
| Total Card Land Units       |          |             |      |    | Parcel Total Land Area |            |          |         |            | Total Land Value |       |           |       |                    |            |            |

| CONSTRUCTION DETAIL   |               |                |            |            |           | CONSTRUCTION DETAIL (CONTINUED) |      |             |            |             |     |
|---|---------------|----------------|------------|------------|-----------|---------------------------------|------|-------------|------------|-------------|-----|
| Element   | Cd            | Description    |            |            |           | Element                         | Cd   | Description |            |             |     |
| Style   | 03            | Colonial       |            |            |           |                                 |      |             |            |             |     |
| Model   | 01            | Residential    |            |            |           |                                 |      |             |            |             |     |
| Grade:  | X+            | Exceptional Pl |            |            |           |                                 |      |             |            |             |     |
| Stories   | 2             | 2 Stories      |            |            |           |                                 |      |             |            |             |     |
| Exterior Wall 1   | 14            | Wood Shingle   |            |            |           | <b>CONDO DATA</b>               |      |             |            |             |     |
| Exterior Wall 2   |               |                |            |            |           | Parcel Id                       |      | C           |            | Owne        | 0.0 |
| Roof Structure  | 03            | Gable/Hip      |            |            |           |                                 |      | B           |            | S           |     |
| Roof Cover  | 03            | Asph/F Gls/Cmp |            |            |           | Adjust Type                     | Code | Description |            | Factor%     |     |
| Interior Wall 1   | 05            | Drywall        |            |            |           | Condo Flr                       |      |             |            |             |     |
| Interior Wall 2   |               |                |            |            |           | Condo Unit                      |      |             |            |             |     |
| Interior Floor 1  | 12            | Hardwood       |            |            |           | <b>COST / MARKET VALUATION</b>  |      |             |            |             |     |
| Interior Floor 2  | 14            | Carpet         |            |            |           | Building Value New              |      |             |            |             |     |
| Heat Fuel   | 03            | Gas            |            |            |           | Year Built                      |      |             |            |             |     |
| Heat Type   | 04            | Hot Air        |            |            |           | Effective Year Built            |      |             |            |             |     |
| AC Type   | 03            | Central        |            |            |           | Depreciation Code               |      |             |            |             |     |
| Bedrooms  | 05            | 5 Bedrooms     |            |            |           | Remodel Rating                  |      |             |            |             |     |
| Full Baths  | 4             |                |            |            |           | Year Remodeled                  |      |             |            |             |     |
| Half Baths  | 1             |                |            |            |           | Depreciation %                  |      |             |            |             |     |
| Extra Fixtures  |               |                |            |            |           | Functional Obsol                |      |             |            |             |     |
| Total Rooms   | 10            | 10 Rooms       |            |            |           | External Obsol                  |      |             |            |             |     |
| Bath Style  |               |                |            |            |           | Trend Factor                    |      |             |            |             |     |
| Kitchen Style   |               |                |            |            |           | Condition                       |      |             |            |             |     |
| Occupancy   |               |                |            |            |           | Condition %                     |      |             |            |             |     |
| Usrflid 105   |               |                |            |            |           | Percent Good                    |      |             |            |             |     |
| Accessory Apt   |               |                |            |            |           | RCNLD                           |      |             |            |             |     |
| Foundation Alt  | 01            | Poured Conc.   |            |            |           | Dep % Ovr                       |      |             |            |             |     |
| Rms Prts  |               |                |            |            |           | Dep Ovr Comment                 |      |             |            |             |     |
| Bath Split  | 41            | 4 Full-1 Half  |            |            |           | Misc Imp Ovr                    |      |             |            |             |     |
|   |               |                |            |            |           | Misc Imp Ovr Comment            |      |             |            |             |     |
|   |               |                |            |            |           | Cost to Cure Ovr                |      |             |            |             |     |
|   |               |                |            |            |           | Cost to Cure Ovr Comment        |      |             |            |             |     |
| <b>OB - OUTBUILDING &amp; YARD ITEMS(L) / XF - BUILDING EXTRA FEATURES(B)</b> |               |                |            |            |           |                                 |      |             |            |             |     |
| Code  | Description   | L/B            | Units      | Unit Price | Yr Blt    | Cond. Cd                        | % Gd | Grade       | Grade Adj. | Appr. Value |     |
| FPIT  | Fire Pit      | L              | 1          | 3010.00    | 2021      |                                 | 100  | C           | 1.00       | 3,000       |     |
| PATF  | Flagstone Pav | L              | 1,088      | 30.00      | 2021      |                                 | 100  |             | 0.00       | 29,100      |     |
| <b>BUILDING SUB-AREA SUMMARY SECTION</b>                                      |               |                |            |            |           |                                 |      |             |            |             |     |
| Code  | Description   | Living Area    | Floor Area | Eff Area   | Unit Cost | Undeprec Value                  |      |             |            |             |     |
|   |               |                |            |            |           |                                 |      |             |            |             |     |
| Ttl Gross Liv / Lease Area  |               |                |            |            |           |                                 |      |             |            |             |     |