

CURRENT OWNER		TOPO	UTILITIES	STRT / ROAD	LOCATION	CURRENT ASSESSMENT			
MAGUIRE, MICHAEL J & KAREN A PO BOX 313 W HYANNISPOR MA 02672		1 Level	2 Public Water	1 Paved		Description	Code	Assessed	Assessed
			4 Gas			RESIDENTL	1010	795,900	795,900
			6 Septic			RES LAND	1010	857,200	857,200
SUPPLEMENTAL DATA									
Alt Prcl ID		Split Zonin		Plan Ref.					
BID Parcel		ResExpt Q YES:		Land Ct#					
#DL 1				#SR					
#DL 2				Life Estate					
GIS ID F_976856_2694493				PP STATU					
				Assoc Pid#					
						Total		1,653,100	1,653,100

801
 FY2024
 BARNSTABLE, MA

VISION

RECORD OF OWNERSHIP		BK-VOL/PAGE	SALE DATE	Q/U	V/I	SALE PRIC	VC	PREVIOUS ASSESSMENTS (HISTORY)									
MAGUIRE, MICHAEL J & KAREN A		16242	0096	01-15-2003	Q	I	580,000	00	Year	Code	Assessed	Year	Code	Assessed	Year	Code	Assessed
THIBEAULT, GEORGE W & A H		3262	0155	04-02-1981	Q		120,000	U	2023	1010	705,500	2022	1010	597,800	2021	1010	494,600
										1010	708,400		1010	461,800		1010	419,800
																1010	17,200
									Total		1,413,900	Total		1,059,600	Total		931,600

EXEMPTIONS				OTHER ASSESSMENTS				This signature acknowledges a visit by a Data Collector or Assessor												
Year	Code	Description	Amount	Code	Description	Number	Amount	Comm Int												
2021	5C	RESIDENTIAL EXEMPTION	0.00																	
			Total																	
			0.00																	

ASSESSING NEIGHBORHOOD				OTHER ASSESSMENTS				APPRAISED VALUE SUMMARY									
Nbhd	Nbhd Name	B		Tracing		Batch											
0112						CENVIL											

NOTES														APPRAISED VALUE SUMMARY				
														Appraised Bldg. Value (Card)	714,300			
														Appraised Xf (B) Value (Bldg)	65,100			
														Appraised Ob (B) Value (Bldg)	16,500			
														Appraised Land Value (Bldg)	857,200			
														Special Land Value	0			
														Total Appraised Parcel Value	1,653,100			
														Valuation Method	C			
														Total Appraised Parcel Value	1,653,100			

BUILDING PERMIT RECORD										VISIT / CHANGE HISTORY					
Permit Id	Issue Date	Type	Description	Amount	Insp Date	% Comp	Date Comp	Comments		Date	Id	Type	Is	Cd	Purpost/Result
17-3382	03-22-2020	834	Sheet Metal	0		100		installation of hvac duct to new		11-24-2020	PK	03		16	In Office Review
17-2764	09-06-2017	804	Addn Alt-Res	20,000	04-24-2018	100	06-30-2018	BUILD 15'X12' BREAKFAST N		11-17-2020	CK	22		22	Change of Address
200806969	01-16-2009	RA	Remodel-Additi	205,000	07-27-2009	100	06-30-2009			05-20-2020	WD			FR	Field Review
20060246	05-05-2006	OB	Out Building		09-14-2006	100	06-30-2007	SHED 120SF		08-03-2018	SR	02		02	Bldg Permit Completed
										03-13-2017	JR	03		03	Cycl Insp Comp
										09-10-2014	JR	03		16	In Office Review
										03-09-2010	PT	04		44	Drive by inspection only

LAND LINE VALUATION SECTION																	
B	Use Code	Description	Zone	LA	Land Units	Unit Price	Size Adj	AC Disc	Site Index	Cond.	Nbhd.	Nbhd. Adj	Notes		Location Adjustmen	Adj Unit P	Land Value
1	1010	Single Fam M-0	RD-	3	0.460	AC	176,344.00	1.92125	1.0000	5	1.00	0112	5.500		1.0000	1,863,409	857,200

CONSTRUCTION DETAIL			CONSTRUCTION DETAIL (CONTINUED)		
Element	Cd	Description	Element	Cd	Description
Style	04	Cape Cod			
Model	01	Residential			
Grade:	B-	Custom Minus			
Stories	1.5	1 1/2 Stories			
Exterior Wall 1	14	Wood Shingle			
Exterior Wall 2					
RooF Structure	03	Gable/Hip			
RooF Cover	03	Asph/F Gls/Cmp			
Interior Wall 1	05	Drywall			
Interior Wall 2					
Interior Floor 1	14	Carpet			
Interior Floor 2	12	Hardwood			
Heat Fuel	03	Gas			
Heat Type	04	Hot Air			
AC Type	03	Central			
Bedrooms	03	3 Bedrooms			
Full Baths	2				
Half Baths	1				
Extra Fixtures					
Total Rooms	7				
Bath Style					
Kitchen Style					
Occupancy					
Usrflid 105					
Accessory Apt					
Foundation Alt	08	Mixed			
Rms Prts					
Bath Split	21	2 Full-1 Half			
			CONDO DATA		
			Parcel Id	C	Owne 0.0
			Adjust Type	Code	Description
			Condo Flr		Factor%
			Condo Unit		
			COST / MARKET VALUATION		
			Building Value New		830,529
			Year Built		1980
			Effective Year Built		2001
			Depreciation Code		G
			Remodel Rating		
			Year Remodeled		
			Depreciation %		14
			Functional Obsol		0
			External Obsol		0
			Trend Factor		1
			Condition		
			Condition %		
			Percent Good		86
			RCNLD		714,300
			Dep % Ovr		
			Dep Ovr Comment		
			Misc Imp Ovr		
			Misc Imp Ovr Comment		
			Cost to Cure Ovr		
			Cost to Cure Ovr Comment		

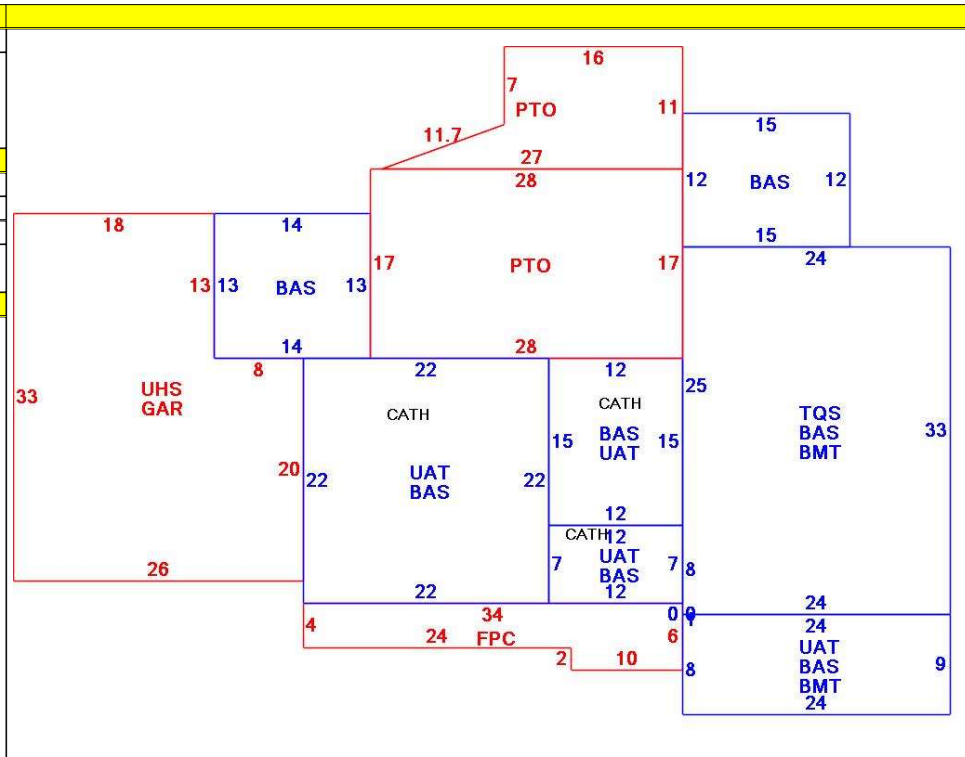

OB - OUTBUILDING & YARD ITEMS(L) / XF - BUILDING EXTRA FEATURES(B)										
Code	Description	L/B	Units	Unit Price	Yr Blt	Cond. Cd	% Gd	Grade	Grade Adj.	Appr. Value
FPL2	Fireplace 1.5 s	B	2	6000.00	2003		86		0.00	10,300
PATC	Conc Pavers	L	476	15.46	2010		91		0.00	6,500
FOPC	Open Prch-roo	B	156	47.28	2001		100	B-	0.00	5,400
GAR	Attached Gara	B	754	33.43	2001		100	B-	0.00	20,800
BMT	Basement-Unfi	B	1,008	26.01	2001		100		0.00	26,700
SHED	Shed	L	120	14.64	2010		82		0.00	1,400
PATC	Conc Pavers	L	198	15.46	2017		98		0.00	3,300
GEN	Emergency Ge	L	1	5550.00	2017		96		0.00	5,300
FPLG	Gas Fireplace-	B	1	2215.00	2001		86		0.00	1,900

BUILDING SUB-AREA SUMMARY SECTION						
Code	Description	Living Area	Floor Area	Eff Area	Unit Cost	Undeprec Value
BAS	First Floor	2,118	2,118	2,118	281.06	595,283
BMT	Basement Area	0	1,008	0	0.00	0
FPC	Open Porch Conc. Floor	0	156	0	0.00	0
GAR	Attached Garage	0	754	0	0.00	0
PTO	Patio	0	674	0	0.00	0
TQS	Three Quarter Story	515	792	515	182.76	144,745
UAT	Attic, Unfinished	0	964	96	27.99	26,982
UHS	Half Story, Unfinished	0	754	226	84.24	63,519
Ttl Gross Liv / Lease Area		2,633	7,220	2,955		830,529

