

CURRENT OWNER		TOPO	UTILITIES	STRT / ROAD	LOCATION	CURRENT ASSESSMENT			
BALTAUSKAS, MARIJA R ESTATE OF C/O ELENA STATHIS 117 WINTERGREEN LANE GROTON MA 01450		1 Level	2 Public Water	1 Paved		Description	Code	Assessed	Assessed
			4 Gas			RESIDNTL	1010	243,500	243,500
			6 Septic			RES LAND	1010	262,700	262,700
SUPPLEMENTAL DATA									
		Alt Prcl ID	Split Zonin		Plan Ref. 491/90				
		BID Parcel	ResExpt Q		Land Ct#				
		#DL 1	LOTS 8A, 9B, 19 & 20		#SR				
		#DL 2			Life Estate				
		GIS ID	F_976461_2695759		PP STATU				
					Assoc Pid#				
						Total		506,200	506,200

801
FY2024
BARNSTABLE, MA

VISION

RECORD OF OWNERSHIP		BK-VOL/PAGE	SALE DATE	Q/U	V/I	SALE PRIC	VC	PREVIOUS ASSESSMENTS (HISTORY)							
BALTAUSKAS, MARIJA R ESTATE OF		20969 0260	05-03-2006	U	I	0	1	Year	Code	Assessed	Year	Code	Assessed		
BALTAUSKAS, MARIJA R		19968 0127	06-24-2005	U	I	0	1	2023	1010	206,300	2022	1010	177,100		
BALTAUSKAS, STANLEY P & MARIJA R		8334 0054	12-15-1992	U	I	8,000	A		1010	259,900		1010	166,500		
RIVKIN, ZINOVY & ZINAIDA		8334 0053	12-15-1992	Q	I	1	U					1010	5,500		
BALTAUSKAS, STANLEY P & MARIJA R		5461 0016	12-18-1986	Q	I	107,000	U								
								Total		466,200	Total		343,600	Total	316,200

EXEMPTIONS			OTHER ASSESSMENTS					
Year	Code	Description	Amount	Code	Description	Number	Amount	Comm Int
Total			0.00					

This signature acknowledges a visit by a Data Collector or Assessor

ASSESSING NEIGHBORHOOD			
Nbhd	Nbhd Name	B	Tracing
0107			CENVIL

APPRAISED VALUE SUMMARY

Appraised Bldg. Value (Card)	234,300
Appraised Xf (B) Value (Bldg)	3,700
Appraised Ob (B) Value (Bldg)	5,500
Appraised Land Value (Bldg)	262,700
Special Land Value	0
Total Appraised Parcel Value	506,200
Valuation Method	C
Total Appraised Parcel Value	506,200

NOTES									

BUILDING PERMIT RECORD								VISIT / CHANGE HISTORY						
Permit Id	Issue Date	Type	Description	Amount	Insp Date	% Comp	Date Comp	Comments	Date	Id	Type	Is	Cd	Purpost/Result
18197	09-26-1996	AD	Addition	7,000	06-29-1997	100	01-01-1997		05-21-2020	WD			FR	Field Review
14435	04-10-1996	AD	Addition	1,600	06-21-1997	100	01-01-1997	DEck	08-31-2017	SR	02		03	Cycl Insp Comp
B37693	05-01-1995	WD	Wood Deck	2,000	01-15-1996	100	12-31-1996	HP DECK	11-07-2006	JK	22		22	Change of Address
									06-23-2003	PT	02		01	Meas/Est
									12-14-2001	PT	01		00	Meas/Listed-Interior Acces
									06-23-2001	PT	02		01	Meas/Est
									05-17-1998	LK				

LAND LINE VALUATION SECTION																
B	Use Code	Description	Zone	LA	Land Units	Unit Price	Size Adj	AC Disc	Site Index	Cond.	Nbhd.	Nbhd. Adj	Notes	Location Adjustmen	Adj Unit P	Land Value
1	1010	Single Fam M-0	RB	3	0.420 AC	176,344.00	2.08655	1.0000	5	1.00	0108	1.700		1.0000	625,509.8	262,700
Total Card Land Units					0.42	AC	Parcel Total Land Area					0.42	Total Land Value			262,700

CONSTRUCTION DETAIL			CONSTRUCTION DETAIL (CONTINUED)		
Element	Cd	Description	Element	Cd	Description
Style	01	Ranch			
Model	01	Residential			
Grade:	C	Average			
Stories	1	1 Story			
Exterior Wall 1	14	Wood Shingle			
Exterior Wall 2					
RooF Structure	03	Gable/Hip			
RooF Cover	03	Asph/F Gls/Cmp			
Interior Wall 1	05	Drywall			
Interior Wall 2					
Interior Floor 1	12	Hardwood			
Interior Floor 2					
Heat Fuel	03	Gas			
Heat Type	04	Hot Air			
AC Type	03	Central			
Bedrooms	02	2 Bedrooms			
Full Baths	1				
Half Baths	0				
Extra Fixtures					
Total Rooms	4	4 Rooms			
Bath Style					
Kitchen Style					
Occupancy					
UsrflD 105					
Accessory Apt					
Foundation Alt	09	Blk/Pour Ftgs			
Rms Prts					
Bath Split	10	1 Full-0 Half			

CONDO DATA			
Parcel Id		C	Owne 0.0
Adjust Type	Code	Description	Factor%
Condo Flr			
Condo Unit			

COST / MARKET VALUATION	
Building Value New	320,992
Year Built	1956
Effective Year Built	1984
Depreciation Code	A
Remodel Rating	
Year Remodeled	
Depreciation %	27
Functional Obsol	0
External Obsol	0
Trend Factor	1
Condition	
Condition %	
Percent Good	73
RCNLD	234,300
Dep % Ovr	
Dep Ovr Comment	
Misc Imp Ovr	
Misc Imp Ovr Comment	
Cost to Cure Ovr	
Cost to Cure Ovr Comment	

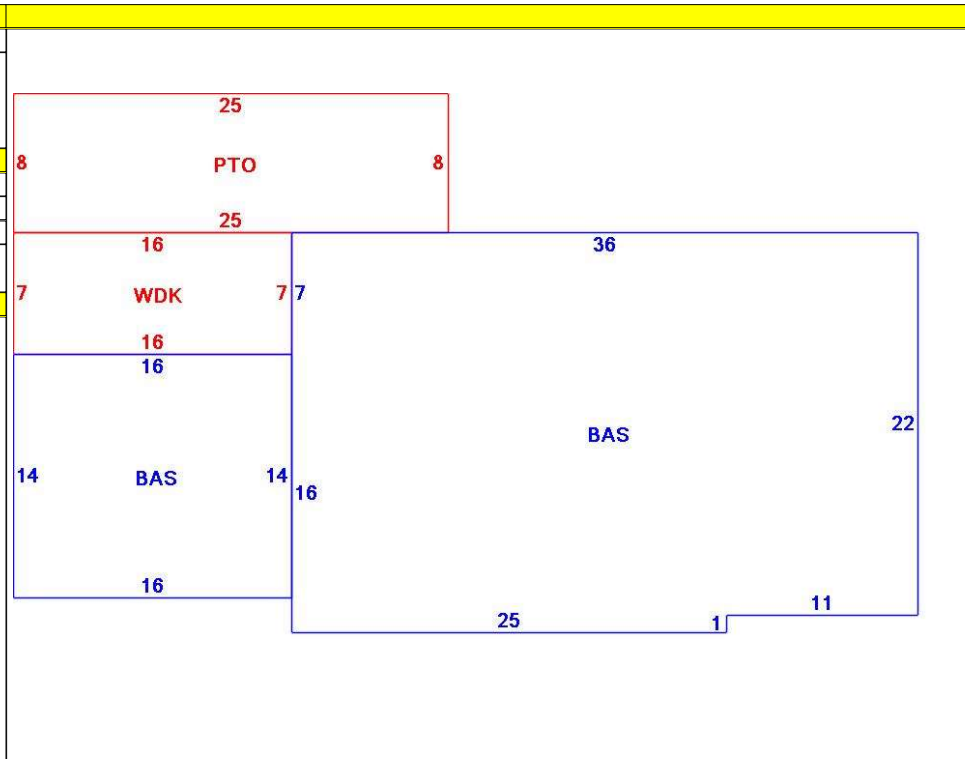

OB - OUTBUILDING & YARD ITEMS(L) / XF - BUILDING EXTRA FEATURES(B)										
Code	Description	L/B	Units	Unit Price	Yr Blt	Cond. Cd	% Gd	Grade	Grade Adj.	Appr. Value
FPL1	Fireplace 1 sto	B	1	5000.00	1986		73		0.00	3,700
SHD2	Shed w/Elec	L	160	26.00	1996		54		0.00	2,200
WDC	Wood Decking	L	112	20.00	1992		46		0.00	1,700
PAT2	Patio-Good	L	200	9.94	1992		73		0.00	1,600

BUILDING SUB-AREA SUMMARY SECTION						
Code	Description	Living Area	Floor Area	Eff Area	Unit Cost	Undeprec Value
BAS	First Floor	1,041	1,041	1,041	308.35	320,992
PTO	Patio	0	200	0	0.00	0
WDK	Wood Deck	0	112	0	0.00	0
Ttl Gross Liv / Lease Area		1,041	1,353	1,041		320,992

