

CURRENT OWNER		TOPO	UTILITIES	STRT / ROAD	LOCATION	CURRENT ASSESSMENT			
FLINTON, ROBERT H & LINDA J  21 ANDREWS DRIVE  UXBRIDGE MA 01569		1 Level	6 Septic	1 Paved		Description	Code	Assessed	Assessed
			4 Gas			RESIDENTL	1010	333,900	333,900
			2 Public Water			RES LAND	1010	209,500	209,500
<b>SUPPLEMENTAL DATA</b>						Total			
Alt Prcl ID Split Zonin BID Parcel ResExpt Q #DL 1 LOTS 192, 194 & 196 #DL 2 BLOCK A GIS ID F_978960_2695570				Plan Ref. 34/23 Land Ct# #SR Life Estate PP STATU Assoc Pid#		543,400			

801  
 FY2024  
 BARNSTABLE, MA  
**VISION**

RECORD OF OWNERSHIP		BK-VOL/PAGE	SALE DATE	Q/U	V/I	SALE PRIC	VC	PREVIOUS ASSESSMENTS (HISTORY)								
FLINTON, ROBERT H & LINDA J		10526 0314	12-16-1996	Q	I	95,000	00	Year	Code	Assessed	Year	Code	Assessed	Year	Code	Assessed
HEALY, LILLIAN B		10454 0348	10-28-1996	U	I	1	1A	2023	1010	268,700	2022	1010	231,600	2021	1010	179,900
HEALY, TIMOTHY J & LILLIAN B		3081 0267	04-11-1980	U		0			1010	190,400		1010	131,000		1010	133,000
								Total		459,100	Total		362,600	Total		318,900

EXEMPTIONS			OTHER ASSESSMENTS					
Year	Code	Description	Amount	Code	Description	Number	Amount	Comm Int
		Total	0.00					

This signature acknowledges a visit by a Data Collector or Assessor

ASSESSING NEIGHBORHOOD				APPRAISED VALUE SUMMARY		
Nbhd	Nbhd Name	B	Tracing	Batch		
0107				HYAN		
<b>NOTES</b>					Appraised Bldg. Value (Card)	315,600
					Appraised Xf (B) Value (Bldg)	12,300
					Appraised Ob (B) Value (Bldg)	6,000
					Appraised Land Value (Bldg)	209,500
					Special Land Value	0
					Total Appraised Parcel Value	543,400
					Valuation Method	C
					Total Appraised Parcel Value	543,400

BUILDING PERMIT RECORD								VISIT / CHANGE HISTORY						
Permit Id	Issue Date	Type	Description	Amount	Insp Date	% Comp	Date Comp	Comments	Date	Id	Type	Is	Cd	Purpost/Result
17-649	03-10-2017	835	Sid/Wind/Roof/	15,638		100		reside replacement windows (	12-20-2022	DB	02		03	Cycl Insp Comp
17-337	02-24-2017	822	Insulation	5,000		100		INSULATION/WEATHERIZATI	05-20-2020	WD			FR	Field Review
201403348	05-29-2014	WD	Wood Deck	6,000	08-22-2014	100	06-15-1930	WD REBLD EXIST	03-21-2017	AL	03		16	In Office Review
20060255	05-08-2006	NR	New Roof	0	06-30-2006	100	06-30-2006	NR REROOF, STRP OLD SHI	07-27-2016	TG	03		22	Change of Address
									12-01-2015	MW	02		02	Bldg Permit Completed
									08-25-2014	SR	02		03	Cycl Insp Comp

LAND LINE VALUATION SECTION																
B	Use Code	Description	Zone	LA	Land Units	Unit Price	Size Adj	AC Disc	Site Index	Cond.	Nbhd.	Nbhd. Adj	Notes	Location Adjustmen	Adj Unit P	Land Value
1	1010	Single Fam M-0	RB	4	0.270 AC	176,344.00	3.14262	1.0000	5	1.00	0107	1.400		1.0000	775,860.7	209,500
Total Card Land Units					0.27	AC	Parcel Total Land Area					0.27	Total Land Value			209,500

CONSTRUCTION DETAIL			CONSTRUCTION DETAIL (CONTINUED)		
Element	Cd	Description	Element	Cd	Description
Style	01	Ranch			
Model	01	Residential			
Grade:	C	Average			
Stories	1	1 Story			
Exterior Wall 1	14	Wood Shingle			
Exterior Wall 2					
RooF Structure	03	Gable/Hip			
RooF Cover	03	Asph/F Gls/Cmp			
Interior Wall 1	02	Wall Brd/Wood			
Interior Wall 2					
Interior Floor 1	12	Hardwood			
Interior Floor 2					
Heat Fuel	03	Gas			
Heat Type	04	Hot Air			
AC Type	03	Central			
Bedrooms	03	3 Bedrooms			
Full Baths	1				
Half Baths	0				
Extra Fixtures					
Total Rooms	6	6 Rooms			
Bath Style					
Kitchen Style					
Occupancy					
Usrflid 105					
Accessory Apt					
Foundation Alt	09	Blk/Pour Ftgs			
Rms Prts					
Bath Split	10	1 Full-0 Half			

CONDO DATA				
Parcel Id		C	Owne	0.0
Adjust Type	Code	Description	Factor%	
Condo Flr				
Condo Unit				

COST / MARKET VALUATION		
Building Value New		404,643
Year Built		1970
Effective Year Built		1991
Depreciation Code		A
Remodel Rating		
Year Remodeled		
Depreciation %		22
Functional Obsol		0
External Obsol		0
Trend Factor		1
Condition		
Condition %		
Percent Good		78
RCNLD		315,600
Dep % Ovr		
Dep Ovr Comment		
Misc Imp Ovr		
Misc Imp Ovr Comment		
Cost to Cure Ovr		
Cost to Cure Ovr Comment		

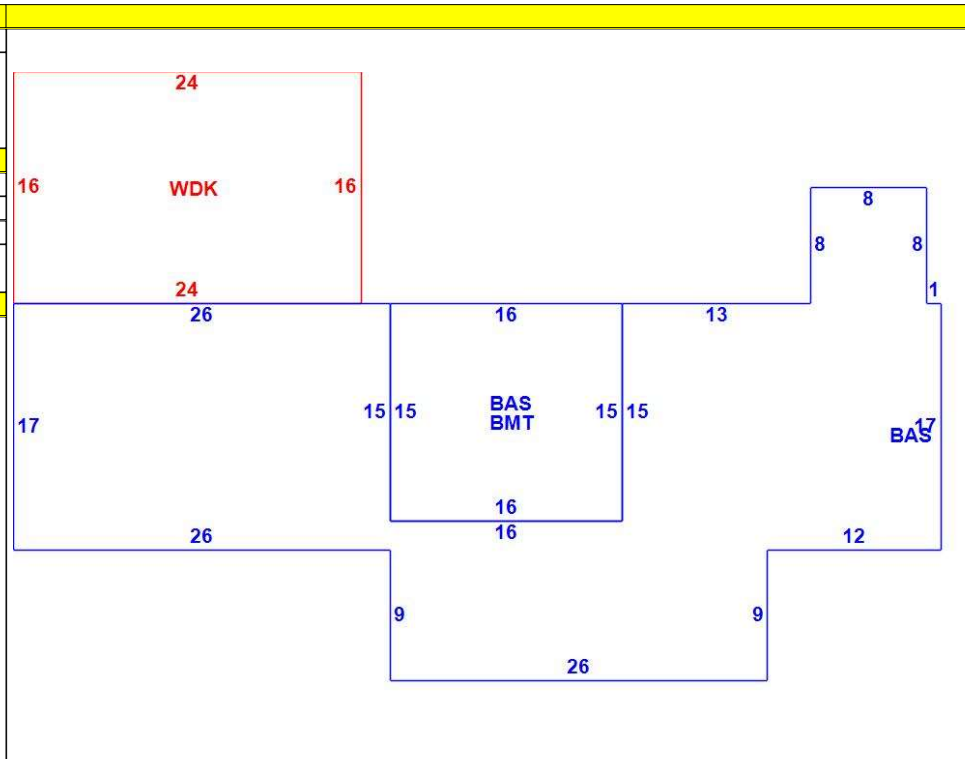

OB - OUTBUILDING & YARD ITEMS(L) / XF - BUILDING EXTRA FEATURES(B)										
Code	Description	L/B	Units	Unit Price	Yr Blt	Cond. Cd	% Gd	Grade	Grade Adj.	Appr. Value
FPL1	Fireplace 1 sto	B	1	5000.00	1993		78		0.00	3,900
BMT	Basement-Unfi	B	240	26.01	1993		78		0.00	8,400
WDC	Wood Deck w/	L	384	18.00	2014		90		0.00	6,000

BUILDING SUB-AREA SUMMARY SECTION						
Code	Description	Living Area	Floor Area	Eff Area	Unit Cost	Undeprec Value
BAS	First Floor	1,386	1,386	1,386	291.95	404,643
BMT	Basement Area	0	240	0	0.00	0
WDC	Wood Deck	0	384	0	0.00	0
Ttl Gross Liv / Lease Area		1,386	2,010	1,386		404,643

