

| CURRENT OWNER  |  | TOPO    | UTILITIES      | STRT / ROAD   | LOCATION | CURRENT ASSESSMENT |      |          |          | 801<br>FY2024<br>BARNSTABLE, MA<br><br><b>VISION</b> |         |
|--|--|---------|----------------|---|----------|--------------------|------|----------|----------|--|---------|
| MANTYLA, RAYMOND H JR & DEBRA<br><br>4 PRATT LANE<br><br>SHREWSBURY MA 01545                               |  | 1 Level | 2 Public Water | 1 Paved   |          | Description        | Code | Assessed | Assessed |  |         |
|  |  |         | 4 Gas          |   |          | RESIDENTL          | 1010 | 430,500  | 430,500  |  |         |
|  |  |         | 6 Septic       |   |          | RES LAND           | 1010 | 223,500  | 223,500  |  |         |
| <b>SUPPLEMENTAL DATA</b>   |  |         |                |   |          | Total              |      |          |          | 654,000  | 654,000 |
| Alt Prcl ID<br>Split Zonin<br>BID Parcel<br>ResExpt Q<br>#DL 1 LOT 35A<br>#DL 2<br>GIS ID F_943017_2685506 |  |         |                | Plan Ref. 159/117<br>Land Ct#<br>#SR<br>Life Estate<br>PP STATU<br>Assoc Pid# |          |                    |      |          |          |  |         |

| RECORD OF OWNERSHIP             |       | BK-VOL/PAGE | SALE DATE  | Q/U | V/I | SALE PRIC | VC | PREVIOUS ASSESSMENTS (HISTORY) |      |          |      |         |          |       |      |          |  |
|---------------------------------|-------|-------------|------------|-----|-----|-----------|----|--------------------------------|------|----------|------|---------|----------|-------|------|----------|--|
| MANTYLA, RAYMOND H JR & DEBRA O | 27611 | 0193        | 08-09-2013 | Q   | I   | 383,000   | 00 | Year                           | Code | Assessed | Year | Code    | Assessed | Year  | Code | Assessed |  |
| LORANTOS, MARTHA E              | 13278 | 0032        | 10-03-2000 | U   | I   | 149,000   | 1K | 2023                           | 1010 | 368,700  | 2022 | 1010    | 320,300  | 2021  | 1010 | 247,000  |  |
| ALLEN, JANE L                   | 2572  | 0262        | 08-30-1977 | U   |     | 0         |    |                                | 1010 | 203,100  |      | 1010    | 139,700  |       | 1010 | 141,900  |  |
| Total                           |       |             |            |     |     |           |    | 571,800                        |      | Total    |      | 460,000 |          | Total |      | 396,600  |  |

| EXEMPTIONS |      |             |        | OTHER ASSESSMENTS |             |        |        | This signature acknowledges a visit by a Data Collector or Assessor |  |  |  |  |  |  |  |  |  |  |
|------------|------|-------------|--------|-------------------|-------------|--------|--------|---|--|--|--|--|--|--|--|--|--|--|
| Year       | Code | Description | Amount | Code              | Description | Number | Amount | Comm Int  |  |  |  |  |  |  |  |  |  |  |
| Total      |      |             | 0.00   |                   |             |        |        |   |  |  |  |  |  |  |  |  |  |  |

| ASSESSING NEIGHBORHOOD |           |   |         | APPRAISED VALUE SUMMARY |                               |         |  |  |  |  |  |  |  |  |  |
|------------------------|-----------|---|---------|-------------------------|-------------------------------|---------|--|--|--|--|--|--|--|--|--|
| Nbhd                   | Nbhd Name | B | Tracing | Batch                   |                               |         |  |  |  |  |  |  |  |  |  |
| 0107                   |           |   | COTUIT  |                         | Appraised Bldg. Value (Card)  | 388,600 |  |  |  |  |  |  |  |  |  |
|                        |           |   |         |                         | Appraised Xf (B) Value (Bldg) | 31,200  |  |  |  |  |  |  |  |  |  |
|                        |           |   |         |                         | Appraised Ob (B) Value (Bldg) | 10,700  |  |  |  |  |  |  |  |  |  |
|                        |           |   |         |                         | Appraised Land Value (Bldg)   | 223,500 |  |  |  |  |  |  |  |  |  |
|                        |           |   |         |                         | Special Land Value            | 0       |  |  |  |  |  |  |  |  |  |
|                        |           |   |         |                         | Total Appraised Parcel Value  | 654,000 |  |  |  |  |  |  |  |  |  |
|                        |           |   |         |                         | Valuation Method              | C       |  |  |  |  |  |  |  |  |  |
|                        |           |   |         |                         | Total Appraised Parcel Value  | 654,000 |  |  |  |  |  |  |  |  |  |

| NOTES     |            |      |                |        |            |        |            |                              |            | VISIT / CHANGE HISTORY |      |    |    |                     |  |  |  |  |  |
|-----------|------------|------|----------------|--------|------------|--------|------------|------------------------------|------------|------------------------|------|----|----|---------------------|--|--|--|--|--|
| Permit Id | Issue Date | Type | Description    | Amount | Insp Date  | % Comp | Date Comp  | Comments                     | Date       | Id                     | Type | Is | Cd | Purpost/Result      |  |  |  |  |  |
| 20-2911   | 10-09-2020 | 822  | Insulation     | 5,000  | 06-30-2021 | 100    | 06-30-2021 | Add R-42 cellulose, and R-22 | 08-27-2021 | CK                     | 02   |    | 03 | Cycl Insp Comp      |  |  |  |  |  |
| 200707054 | 11-09-2007 | AD   | Addition       | 68,400 | 02-25-2008 | 100    | 06-30-2008 | 2 BRS 1/2, BATH              | 06-03-2020 | DM                     |      |    | FR | Field Review        |  |  |  |  |  |
| 68005     | 04-08-2003 | RA   | Remodel-Additi | 35,000 | 11-14-2003 | 100    | 01-01-2004 |                              | 12-10-2012 | DR                     | 22   |    | 22 | Change of Address   |  |  |  |  |  |
| 52386     | 03-26-2001 | OB   | Out Building   | 3,600  | 10-05-2001 | 100    | 01-01-2002 | 12 X 20                      | 09-28-2012 | RB                     | 03   |    | 16 | In Office Review    |  |  |  |  |  |
|           |            |      |                |        |            |        |            |                              | 04-16-2008 | JG                     | 03   |    | 16 | In Office Review    |  |  |  |  |  |
|           |            |      |                |        |            |        |            |                              | 02-25-2008 | PT                     | 02   |    | 14 | Cyclical Inspection |  |  |  |  |  |
|           |            |      |                |        |            |        |            |                              | 12-20-2004 | PT                     | 02   |    | 01 | Meas/Est            |  |  |  |  |  |

| LAND LINE VALUATION SECTION |          |                |      |    |            |            |                        |         |            |       |       |           |                  |                    |            |            |         |
|-----------------------------|----------|----------------|------|----|------------|------------|------------------------|---------|------------|-------|-------|-----------|------------------|--------------------|------------|------------|---------|
| B                           | Use Code | Description    | Zone | LA | Land Units | Unit Price | Size Adj               | AC Disc | Site Index | Cond. | Nbhd. | Nbhd. Adj | Notes            | Location Adjustmen | Adj Unit P | Land Value |         |
| 1                           | 1010     | Single Fam M-0 | RF   | 2  | 0.530      | AC         | 176,344.00             | 1.70777 | 1.0000     | 5     | 1.00  | 0107      | 1.400            |                    | 1.0000     | 421,620.8  | 223,500 |
| Total Card Land Units       |          |                |      |    | 0.53       | AC         | Parcel Total Land Area |         |            |       |       | 0.53      | Total Land Value |                    |            |            | 223,500 |

| CONSTRUCTION DETAIL |    |                | CONSTRUCTION DETAIL (CONTINUED) |    |             |
|---------------------|----|----------------|---------------------------------|----|-------------|
| Element             | Cd | Description    | Element                         | Cd | Description |
| Style               | 01 | Ranch          |                                 |    |             |
| Model               | 01 | Residential    |                                 |    |             |
| Grade:              | C  | Average        |                                 |    |             |
| Stories             | 1  | 1 Story        |                                 |    |             |
| Exterior Wall 1     | 14 | Wood Shingle   |                                 |    |             |
| Exterior Wall 2     |    |                |                                 |    |             |
| Roof Structure      | 03 | Gable/Hip      |                                 |    |             |
| Roof Cover          | 03 | Asph/F Gls/Cmp |                                 |    |             |
| Interior Wall 1     | 05 | Drywall        |                                 |    |             |
| Interior Wall 2     |    |                |                                 |    |             |
| Interior Floor 1    | 12 | Hardwood       |                                 |    |             |
| Interior Floor 2    |    |                |                                 |    |             |
| Heat Fuel           | 03 | Gas            |                                 |    |             |
| Heat Type           | 05 | Hot Water      |                                 |    |             |
| AC Type             | 01 | None           |                                 |    |             |
| Bedrooms            | 04 | 4 Bedrooms     |                                 |    |             |
| Full Baths          | 1  |                |                                 |    |             |
| Half Baths          | 1  |                |                                 |    |             |
| Extra Fixtures      |    |                |                                 |    |             |
| Total Rooms         | 4  | 4 Rooms        |                                 |    |             |
| Bath Style          |    |                |                                 |    |             |
| Kitchen Style       |    |                |                                 |    |             |
| Occupancy           |    |                |                                 |    |             |
| Usrflid 105         |    |                |                                 |    |             |
| Accessory Apt       |    |                |                                 |    |             |
| Foundation Alt      | 01 | Poured Conc.   |                                 |    |             |
| Rms Prts            |    |                |                                 |    |             |
| Bath Split          | 11 | 1 Full-1 Half  |                                 |    |             |

| CONDO DATA  |      |             |         |  |
|-------------|------|-------------|---------|--|
| Parcel Id   | C    | Owne        | 0.0     |  |
|             |      |             |         |  |
| Adjust Type | Code | Description | Factor% |  |
| Condo Flr   |      |             |         |  |
| Condo Unit  |      |             |         |  |

| COST / MARKET VALUATION  |         |
|--------------------------|---------|
| Building Value New       | 485,738 |
| Year Built               | 1964    |
| Effective Year Built     | 1993    |
| Depreciation Code        | G       |
| Remodel Rating           |         |
| Year Remodeled           |         |
| Depreciation %           | 20      |
| Functional Obsol         | 0       |
| External Obsol           | 0       |
| Trend Factor             | 1       |
| Condition                |         |
| Condition %              |         |
| Percent Good             | 80      |
| RCNLD                    | 388,600 |
| Dep % Ovr                |         |
| Dep Ovr Comment          |         |
| Misc Imp Ovr             |         |
| Misc Imp Ovr Comment     |         |
| Cost to Cure Ovr         |         |
| Cost to Cure Ovr Comment |         |

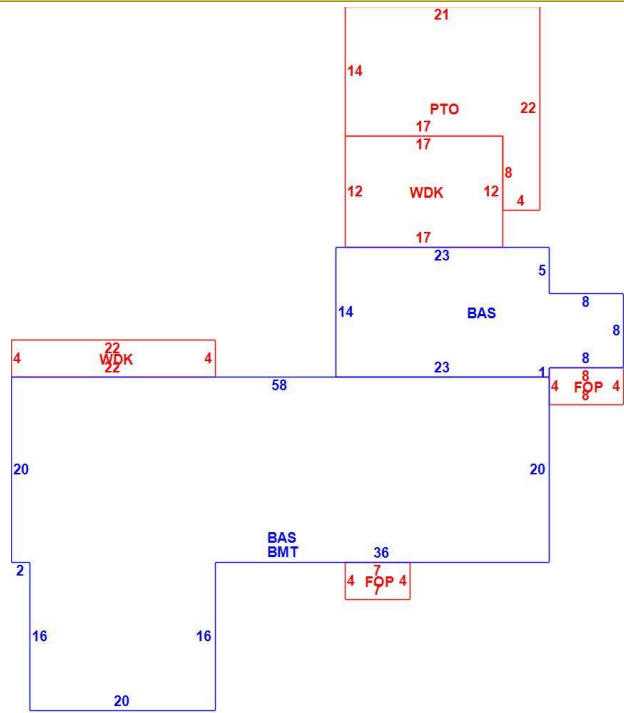

| OB - OUTBUILDING & YARD ITEMS(L) / XF - BUILDING EXTRA FEATURES(B) |               |     |       |            |        |          |      |       |            |             |
|--|---------------|-----|-------|------------|--------|----------|------|-------|------------|-------------|
| Code   | Description   | L/B | Units | Unit Price | Yr Blt | Cond. Cd | % Gd | Grade | Grade Adj. | Appr. Value |
| SHED   | Shed          | L   | 240   | 18.00      | 2001   |          | 64   |       | 0.00       | 2,800       |
| WDC  | Wood Decking  | L   | 204   | 20.00      | 1994   |          | 50   |       | 0.00       | 2,400       |
| FOP  | Open Porch-ro | B   | 60    | 55.00      | 1995   |          | 80   |       | 0.00       | 3,100       |
| BMT  | Basement-Unfi | B   | 1,480 | 26.01      | 1995   |          | 80   |       | 0.00       | 28,100      |
| WDC  | Wood Deck w/  | L   | 88    | 18.00      | 2009   |          | 80   |       | 0.00       | 2,500       |
| PAT2   | Patio-Good    | L   | 326   | 9.94       | 2012   |          | 93   |       | 0.00       | 3,000       |

| BUILDING SUB-AREA SUMMARY SECTION |               |             |            |          |           |                |
|-----------------------------------|---------------|-------------|------------|----------|-----------|----------------|
| Code                              | Description   | Living Area | Floor Area | Eff Area | Unit Cost | Undeprec Value |
| BAS                               | First Floor   | 1,866       | 1,866      | 1,866    | 260.31    | 485,738        |
| BMT                               | Basement Area | 0           | 1,480      | 0        | 0.00      | 0              |
| FOP                               | Open Porch    | 0           | 60         | 0        | 0.00      | 0              |
| PTO                               | Patio         | 0           | 326        | 0        | 0.00      | 0              |
| WDK                               | Wood Deck     | 0           | 292        | 0        | 0.00      | 0              |
| Ttl Gross Liv / Lease Area        |               | 1,866       | 4,024      | 1,866    |           | 485,738        |

