

CURRENT OWNER		TOPO	UTILITIES	STRT / ROAD	LOCATION	CURRENT ASSESSMENT				801 FY2024 BARNSTABLE, MA  <b>VISION</b>
BOURQUE, DANA R TR BOURQUE FAMILY REV TR 179 OLD CRAIGVILLE ROAD		3   Below Street	2   Public Water	1   Paved	9   Rear Location	Description	Code	Assessed	Assessed	
			4   Gas			RESIDNTL	1010	239,500	239,500	
HYANNIS MA 02601		6   Septic				RES LAND	1010	167,200	167,200	
		<b>SUPPLEMENTAL DATA</b>				Total		406,700	406,700	
		Alt Prcl ID	Split Zonin	Plan Ref. 380/13						
		BID Parcel	ResExpt Q NO APP:	Land Ct#						
		#DL 1 LOT 4		#SR						
		#DL 2		Life Estate						
		GIS ID F_978123_2699121		PP STATU						
				Assoc Pid#						

RECORD OF OWNERSHIP		BK-VOL/PAGE	SALE DATE	Q/U	V/I	SALE PRIC	VC	PREVIOUS ASSESSMENTS (HISTORY)					
BOURQUE, DANA R TR		35570 203	12-30-2022	U	I	1	1F	Year	Code	Assessed	Year	Code	Assessed
BOURQUE, JOHN G & DANA R		31258 0240	05-10-2018	Q	I	283,000	00	2023	1010	202,200	2022	1010	167,400
ANTON, VINCENT J		6478 0097	10-15-1988	U	I	1	A		1010	152,000		1010	112,600
ANTON, MICHAEL PAUL &		6427 0269	09-15-1988	U	I	1	B					1010	1,900
ANTON, MICHAEL PAUL		4123 0254	05-15-1984	U	I	33,500	N						
		Total						Total	354,200	Total	280,000	Total	242,800

EXEMPTIONS		OTHER ASSESSMENTS						
Year	Code	Description	Amount	Code	Description	Number	Amount	Comm Int
2020	N5C	NO RESIDENTIAL EXEMPTION	0.00					
Total			0.00					

ASSESSING NEIGHBORHOOD			
Nbhd	Nbhd Name	B	Tracing
0105			Batch HYAN

NOTES			
This signature acknowledges a visit by a Data Collector or Assessor			
<b>APPRAISED VALUE SUMMARY</b>			
Appraised Bldg. Value (Card)			234,200
Appraised Xf (B) Value (Bldg)			0
Appraised Ob (B) Value (Bldg)			5,300
Appraised Land Value (Bldg)			167,200
Special Land Value			0
Total Appraised Parcel Value			406,700
Valuation Method			C
Total Appraised Parcel Value			406,700

BUILDING PERMIT RECORD								VISIT / CHANGE HISTORY						
Permit Id	Issue Date	Type	Description	Amount	Insp Date	% Comp	Date Comp	Comments	Date	Id	Type	Is	Cd	Purpost/Result
B33263	10-01-1989	AD	Addition	7,500	07-27-1998	100		HY ADD'N	10-21-2021	SR	02		03	Cycl Insp Comp
									06-03-2020	DM			FR	Field Review
									03-28-2017	AL	03		16	In Office Review
									04-16-2015	JR	03		03	Cycl Insp Comp
									03-22-2002	MF	04		44	Drive by inspection only
									11-29-2001	PT	01		00	Meas/Listed-Interior Acces
									07-27-1998	LK				

LAND LINE VALUATION SECTION																	
B	Use Code	Description	Zone	LA	Land Units	Unit Price	Size Adj	AC Disc	Site Index	Cond.	Nbhd.	Nbhd. Adj	Notes	Location Adjustmen	Adj Unit P	Land Value	
1	1010	Single Fam M-0	RB	4	0.640 AC	176,344.00	1.48133	1.0000	5	1.00	0105	1.000		1.0000	261,218.3	167,200	
Total Card Land Units					0.64 AC	Parcel Total Land Area					0.64	Total Land Value					167,200

CONSTRUCTION DETAIL			CONSTRUCTION DETAIL (CONTINUED)		
Element	Cd	Description	Element	Cd	Description
Style	01	Ranch			
Model	01	Residential			
Grade:	C	Average			
Stories	1	1 Story			
Exterior Wall 1	14	Wood Shingle			
Exterior Wall 2	11	Clapboard			
RooF Structure	03	Gable/Hip			
RooF Cover	03	Asph/F Gls/Cmp			
Interior Wall 1	05	Drywall			
Interior Wall 2					
Interior Floor 1	12	Hardwood			
Interior Floor 2	05	Vinyl/Asphalt			
Heat Fuel	03	Gas			
Heat Type	05	Hot Water			
AC Type	01	None			
Bedrooms	03	3 Bedrooms			
Full Baths	1				
Half Baths	1				
Extra Fixtures					
Total Rooms	5	5 Rooms			
Bath Style					
Kitchen Style					
Occupancy					
Usrflid 105					
Accessory Apt					
Foundation Alt	09	Blk/Pour Ftgs			
Rms Prts					
Bath Split	11	1 Full-1 Half			

CONDO DATA			
Parcel Id		C	Ownr 0.0
		B	S
Adjust Type	Code	Description	Factor%
Condo Flr			
Condo Unit			

COST / MARKET VALUATION	
Building Value New	339,377
Year Built	1930
Effective Year Built	1979
Depreciation Code	A
Remodel Rating	
Year Remodeled	
Depreciation %	31
Functional Obsol	0
External Obsol	0
Trend Factor	1
Condition	
Condition %	
Percent Good	69
RCNLD	234,200
Dep % Ovr	
Dep Ovr Comment	
Misc Imp Ovr	
Misc Imp Ovr Comment	
Cost to Cure Ovr	
Cost to Cure Ovr Comment	

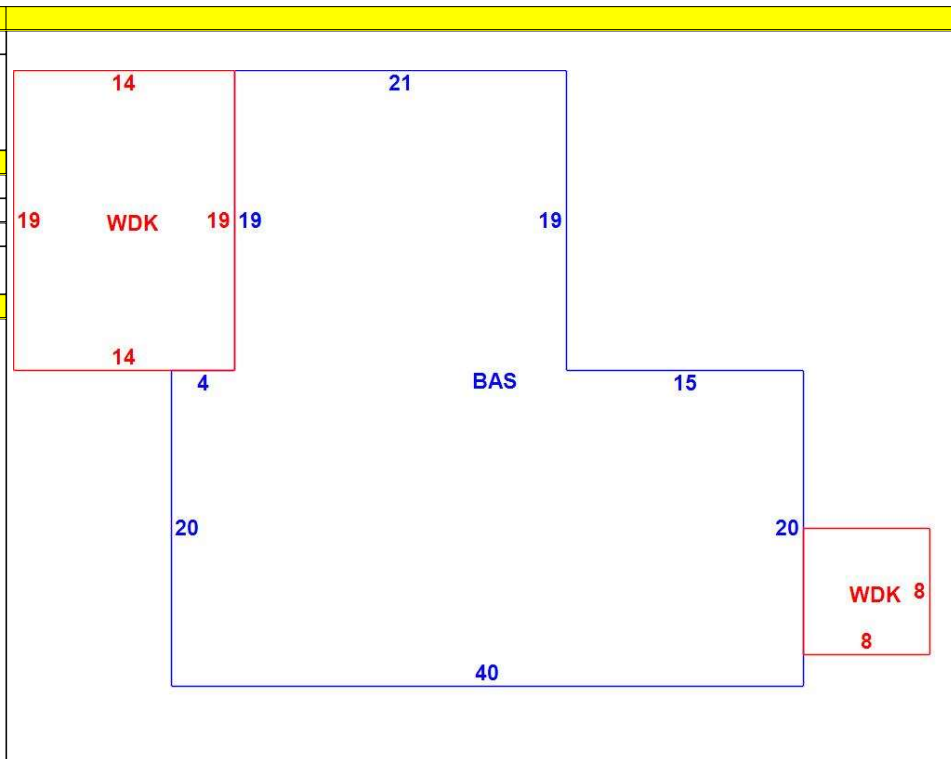

**OB - OUTBUILDING & YARD ITEMS(L) / XF - BUILDING EXTRA FEATURES(B)**

Code	Description	L/B	Units	Unit Price	Yr Blt	Cond. Cd	% Gd	Grade	Grade Adj.	Appr. Value
WDC	Wood Deck w/	L	266	18.00	1986		34		0.00	1,700
WDC	Wood Decking	L	64	20.00	1997		56		0.00	1,800
SHED	Shed	L	120	18.00	1997		56		0.00	1,200
SHED	Shed	L	64	18.00	1997		56		0.00	600

**BUILDING SUB-AREA SUMMARY SECTION**

Code	Description	Living Area	Floor Area	Eff Area	Unit Cost	Undeprec Value
BAS	First Floor	1,199	1,199	1,199	283.05	339,377
WDK	Wood Deck	0	330	0	0.00	0
Ttl Gross Liv / Lease Area		1,199	1,529	1,199		339,377

