

CONSTRUCTION DETAIL			CONSTRUCTION DETAIL (CONTINUED)		
Element	Cd	Description	Element	Cd	Description
Style	04	Cape Cod			
Model	01	Residential			
Grade:	C+	Average Plus			
Stories	1.75	1 3/4 Stories			
Exterior Wall 1	14	Wood Shingle			
Exterior Wall 2	21	Stone/Masonry			
RooF Structure	03	Gable/Hip			
RooF Cover	03	Asph/F Gls/Cmp			
Interior Wall 1	05	Drywall			
Interior Wall 2					
Interior Floor 1	12	Hardwood			
Interior Floor 2	14	Carpet			
Heat Fuel	02	Oil			
Heat Type	05	Hot Water			
AC Type	03	Central			
Bedrooms	04	4 Bedrooms			
Full Baths	2				
Half Baths	1				
Extra Fixtures					
Total Rooms	8	8 Rooms			
Bath Style					
Kitchen Style					
Occupancy					
Usrflid 105					
Accessory Apt					
Foundation Alt	01	Poured Conc.			
Rms Prts					
Bath Split	21	2 Full-1 Half			

CONDO DATA			
Parcel Id	C	Owne	0.0
Adjust Type	Code	Description	Factor%
Condo Flr			
Condo Unit			

COST / MARKET VALUATION	
Building Value New	635,698
Year Built	1978
Effective Year Built	1995
Depreciation Code	A
Remodel Rating	
Year Remodeled	19
Depreciation %	0
Functional Obsol	0
External Obsol	0
Trend Factor	1
Condition	
Condition %	81
Percent Good	514,900
RCNLD	
Dep % Ovr	
Dep Ovr Comment	
Misc Imp Ovr	
Misc Imp Ovr Comment	
Cost to Cure Ovr	
Cost to Cure Ovr Comment	

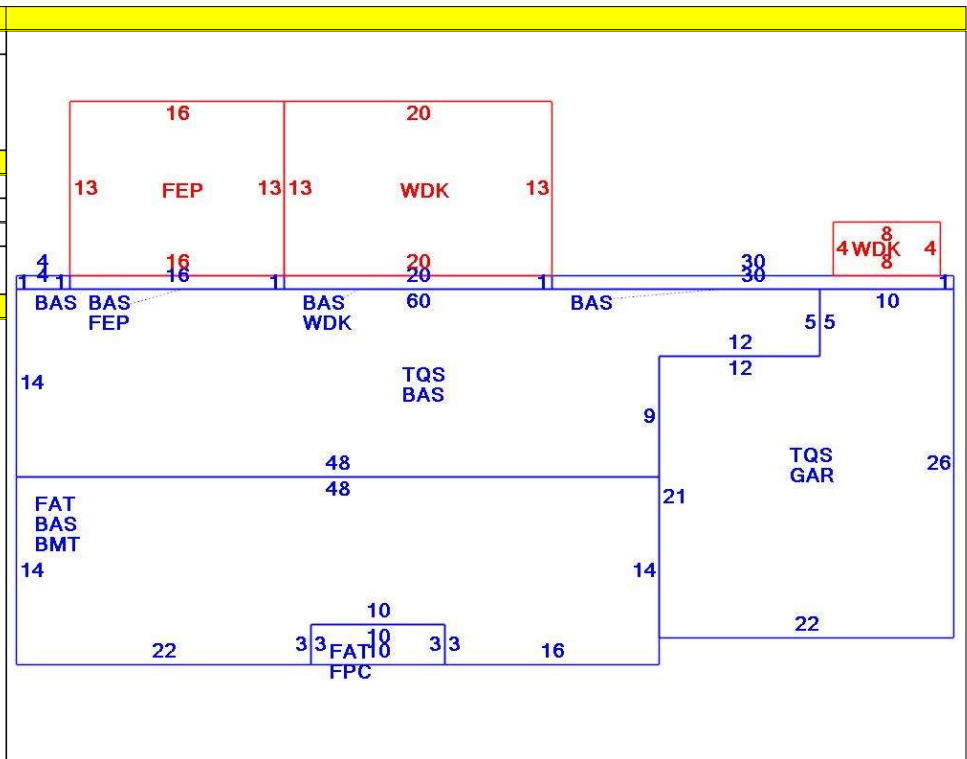

OB - OUTBUILDING & YARD ITEMS(L) / XF - BUILDING EXTRA FEATURES(B)										
Code	Description	L/B	Units	Unit Price	Yr Blt	Cond. Cd	% Gd	Grade	Grade Adj.	Appr. Value
FPL1	Fireplace 1 sto	B	1	5000.00	1997		81		0.00	4,100
BFA1	Bsmt Fin-Goo	B	600	32.56	1997		81		0.00	15,800
WDC	Wood Decking	L	312	20.00	1997		56		0.00	3,500
FOPC	Open Prch-roo	B	30	55.00	1997		81		0.00	1,600
FEP	Enclosed porc	B	224	70.00	1997		81		0.00	10,900
GAR	Attached Gara	B	512	40.00	1997		81		0.00	15,200
BMT	Basement-Unfi	B	1,374	26.01	1997		81		0.00	26,900

BUILDING SUB-AREA SUMMARY SECTION						
Code	Description	Living Area	Floor Area	Eff Area	Unit Cost	Undeprec Value
BAS	First Floor	1,444	1,444	1,444	270.05	389,952
BMT	Basement Area	0	642	0	0.00	0
FAT	Attic, Finished	101	672	101	40.59	27,275
FEP	Enclosed Porch	0	224	0	0.00	0
FPC	Open Porch Conc. Floor	0	30	0	0.00	0
GAR	Attached Garage	0	512	0	0.00	0
TQS	Three Quarter Story	809	1,244	809	175.62	218,470
WDK	Wood Deck	0	312	0	0.00	0
Ttl Gross Liv / Lease Area		2,354	5,080	2,354		635,697

