

CURRENT OWNER		TOPO		UTILITIES		STRT / ROAD		LOCATION		CURRENT ASSESSMENT			
YOUNG, CHRISTOPHER K TR CHRISTOPHER K YOUNG FAM TR 296 LONG POND ROAD		1	Level	6	Septic	1	Paved	1	Lake/Pond Fro	Description	Code	Assessed	Assessed
				2	Public Water			9	Rear Location	RESIDNTL	1010	491,100	491,100
MARSTONS MIL MA 02648		SUPPLEMENTAL DATA										801 FY2024 BARNSTABLE, MA	
		Alt Prcl ID Split Zonin BID Parcel ResExpt Q YES: #DL 1 LOT 6 #DL 2 GIS ID F_943943_2705179					Plan Ref. Land Ct# 37493-B #SR Life Estate PP STATU Assoc Pid#						
										Total	758,200	758,200	

**VISION**

RECORD OF OWNERSHIP		BK-VOL/PAGE		SALE DATE		Q/U		V/I		SALE PRIC		VC		PREVIOUS ASSESSMENTS (HISTORY)							
YOUNG, CHRISTOPHER K TR		C231105	0	09-20-2022		U	I			1	1F	Year	Code	Assessed	Year	Code	Assessed	Year	Code	Assessed	
YOUNG, CHRISTOPHER K		C164419	0	02-28-2002		Q	I			453,000	00	2023	1010	432,600	2022	1010	367,300	2021	1010	314,800	
KIPNES, KENNETH A & LINDA G		C127850	0	09-15-1992		U	V			1	1A		1010	244,600		1010	173,100		1010	175,800	
KIPNES, LINDA G TR		C94229	0	11-15-1983		Q	V			30,000	00								1010	6,000	
												Total	677,200	Total	540,400	Total	496,600				

EXEMPTIONS				OTHER ASSESSMENTS			
Year	Code	Description	Amount	Code	Description	Number	Amount
2011	5C	RESIDENTIAL EXEMPTION	0.00				
Total			0.00				

This signature acknowledges a visit by a Data Collector or Assessor

ASSESSING NEIGHBORHOOD			
Nbhd	Nbhd Name	B	Tracing
0107			MARSTM

APPRAISED VALUE SUMMARY	
Appraised Bldg. Value (Card)	411,700
Appraised Xf (B) Value (Bldg)	68,200
Appraised Ob (B) Value (Bldg)	11,200
Appraised Land Value (Bldg)	267,100
Special Land Value	0
Total Appraised Parcel Value	758,200
Valuation Method	C
Total Appraised Parcel Value	758,200

NOTES									

BUILDING PERMIT RECORD									VISIT / CHANGE HISTORY					
Permit Id	Issue Date	Type	Description	Amount	Insp Date	% Comp	Date Comp	Comments	Date	Id	Type	Is	Cd	Purpost/Result
201304657	07-30-2013	IN	Insulation	2,000	06-30-2014	100	06-30-2014	INSULATE	11-22-2022	SR	01		03	Cycl Insp Comp
B37719	05-01-1995	AD	Addition	28,000	01-15-1996	100	01-15-1996	MM ADD'N	05-20-2020	LS			FR	Field Review
B25960	01-01-1984	DW	Dwelling	0	04-15-1985	100	04-15-1985	MM 1 1/2S	04-10-2018	MS	03		16	In Office Review
									09-11-2014	SR	01		03	Cycl Insp Comp
									07-11-2014	JR	03		16	In Office Review
									08-08-2008	NF	03		16	In Office Review

LAND LINE VALUATION SECTION																	
B	Use Code	Description	Zone	LA	Land Units	Unit Price	Size Adj	AC Disc	Site Index	Cond.	Nbhd.	Nbhd. Adj	Notes	Location Adjustmen	Adj Unit P	Land Value	
1	1010	Single Fam M-0	RF	3	1.000	AC 176,344.00	1.00000	1.0000	5	1.00	0107	1.400	LONG POND		1.0000	246,881.6	
1	1010	Single Fam M-0	RF	3	1.010	AC 14,250.00	1.00000	1.0000	0	1.00	0107	1.400			1.0050	20,200	
Total Card Land Units					2.01	AC	Parcel Total Land Area					2.01	Total Land Value				267,100

CONSTRUCTION DETAIL			CONSTRUCTION DETAIL (CONTINUED)		
Element	Cd	Description	Element	Cd	Description
Style	04	Cape Cod			
Model	01	Residential			
Grade:	C	Average			
Stories	1.75	1 3/4 Stories			
Exterior Wall 1	14	Wood Shingle			
Exterior Wall 2	11	Clapboard			
Roof Structure	03	Gable/Hip			
Roof Cover	03	Asph/F Gls/Cmp			
Interior Wall 1	05	Drywall			
Interior Wall 2					
Interior Floor 1	14	Carpet			
Interior Floor 2	12	Hardwood			
Heat Fuel	02	Oil			
Heat Type	05	Hot Water			
AC Type	03	Central			
Bedrooms	05	5 Bedrooms			
Full Baths	3				
Half Baths	1				
Extra Fixtures					
Total Rooms	9	9 Rooms			
Bath Style					
Kitchen Style					
Occupancy					
Usrflid 105					
Accessory Apt	Y	Apt here			
Foundation Alt	01	Poured Conc.			
Rms Prts					
Bath Split	31	3 Full-1 Half			
			<b>CONDO DATA</b>		
			Parcel Id	C	Ownr 0.0
			Adjust Type Code Description Factor%		
			Condo Flr		
			Condo Unit		
			<b>COST / MARKET VALUATION</b>		
			Building Value New		490,140
			Year Built		1984
			Effective Year Built		1998
			Depreciation Code		A
			Remodel Rating		
			Year Remodeled		
			Depreciation %		16
			Functional Obsol		0
			External Obsol		0
			Trend Factor		1
			Condition		
			Condition %		
			Percent Good		84
			RCNLD		411,700
			Dep % Ovr		
			Dep Ovr Comment		
			Misc Imp Ovr		
			Misc Imp Ovr Comment		
			Cost to Cure Ovr		
			Cost to Cure Ovr Comment		

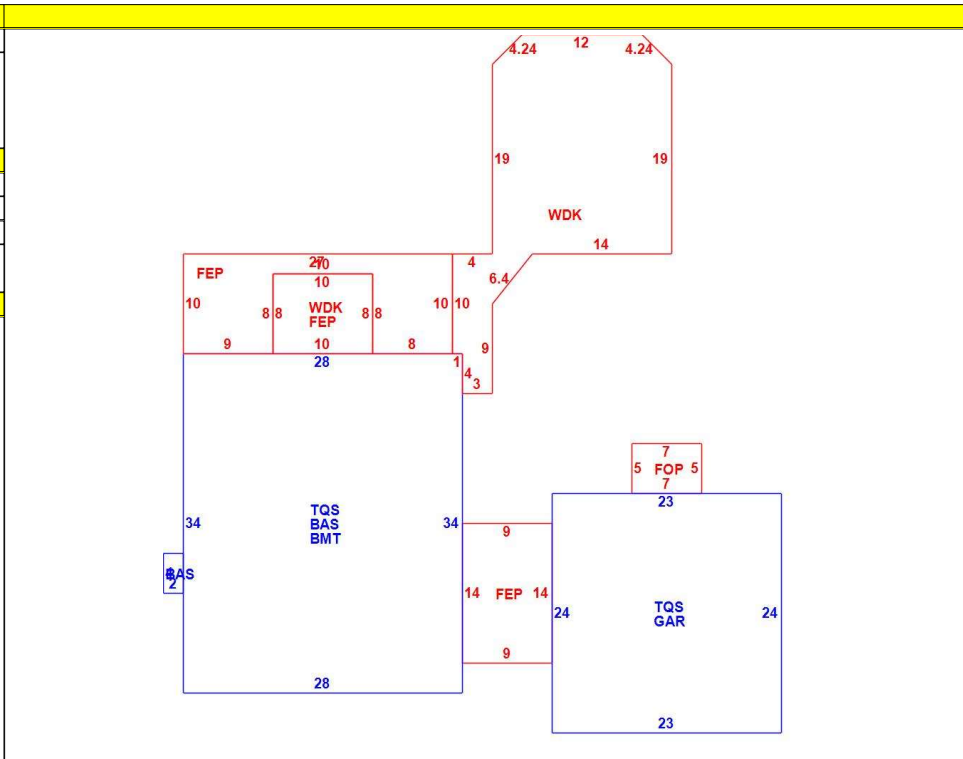

OB - OUTBUILDING & YARD ITEMS(L) / XF - BUILDING EXTRA FEATURES(B)										
Code	Description	L/B	Units	Unit Price	Yr Blt	Cond. Cd	% Gd	Grade	Grade Adj.	Appr. Value
FPL2	Fireplace 1.5 s	B	1	6000.00	2000		84		0.00	5,000
BRR	Bsmnt Rec Rm-	B	720	8.05	2000		84		0.00	4,900
WDC	Wood Decking	L	529	20.00	1999		60		0.00	5,900
FOP	Open Porch-ro	B	35	55.00	2000		84		0.00	2,200
FEP	Enclosed porc	B	396	70.00	2000		84		0.00	17,800
GAR	Attached Gara	B	552	40.00	2000		84		0.00	16,700
BMT	Basement-Unfi	B	952	26.01	2000		84		0.00	21,600
SHED	Shed	L	112	18.00	1997		56		0.00	1,100
DKPL	Pond Dock-Lig	L	1	4200.00	2020		100		0.00	4,200

BUILDING SUB-AREA SUMMARY SECTION							
Code	Description	Living Area	Floor Area	Eff Area	Unit Cost	Undeprec Value	
BAS	First Floor	960	960	960	252.91	242,794	
BMT	Basement Area	0	952	0	0.00	0	
FEP	Enclosed Porch	0	396	0	0.00	0	
FOP	Open Porch	0	35	0	0.00	0	
GAR	Attached Garage	0	552	0	0.00	0	
TQS	Three Quarter Story	978	1,504	978	164.46	247,346	
WDK	Wood Deck	0	529	0	0.00	0	
Ttl Gross Liv / Lease Area		1,938	4,928	1,938		490,140	