

CURRENT OWNER		TOPO	UTILITIES	STRT / ROAD	LOCATION	CURRENT ASSESSMENT				801 FY2024 BARNSTABLE, MA VISION	
NORCROSS, NORMA E 8 VANDERMINT LANE HYANNIS MA 02601		1 Level	2 Public Water	1 Paved		Description	Code	Assessed	Assessed		
			4 Gas			RESIDNTL	1010	307,500	307,500		
			6 Septic			RES LAND	1010	152,200	152,200		
SUPPLEMENTAL DATA						Total				459,700	459,700
Alt Prcl ID Split Zonin BID Parcel ResExpt Q NO APP: #DL 1 LOT 15 #DL 2 GIS ID F_978919_2704598				Plan Ref. 222/31 Land Ct# #SR Life Estate PP STATU Assoc Pid#							

RECORD OF OWNERSHIP		BK-VOL/PAGE	SALE DATE	Q/U	V/I	SALE PRIC	VC	PREVIOUS ASSESSMENTS (HISTORY)								
NORCROSS, NORMA E		34946 095	03-03-2022	U	I	1	1F	Year	Code	Assessed	Year	Code	Assessed	Year	Code	Assessed
NORCROSS, WILLIAM J & NORMA E		29453 0001	02-16-2016	U	I	1	1A	2023	1010	264,100	2022	1010	222,800	2021	1010	188,400
EBERLE, NORMA E		26139 0295	03-08-2012	U	I	1	1A		1010	138,400		1010	102,500		1010	102,500
EBERLE, MARIA C & NORMA E		21265 0112	08-11-2006	Q	I	333,000	00								1010	6,000
BURKE, JAMES J & HANNAH		10092 0257	03-15-1996	Q	I	114,200	U	Total		402,500	Total		325,300	Total		296,900

EXEMPTIONS			OTHER ASSESSMENTS					This signature acknowledges a visit by a Data Collector or Assessor					
Year	Code	Description	Amount	Code	Description	Number	Amount	Comm Int					
2024	N5C	NO RESIDENTIAL EXEMPTION											
Total			0.00										

ASSESSING NEIGHBORHOOD				APPRAISED VALUE SUMMARY			
Nbhd	Nbhd Name	B	Tracing	Batch			
0105				HYAN	Appraised Bldg. Value (Card)	260,300	
					Appraised Xf (B) Value (Bldg)	40,500	
					Appraised Ob (B) Value (Bldg)	6,700	
					Appraised Land Value (Bldg)	152,200	
					Special Land Value	0	
					Total Appraised Parcel Value	459,700	
					Valuation Method	C	
					Total Appraised Parcel Value	459,700	

NOTES										VISIT / CHANGE HISTORY					
										Date	Id	Type	Is	Cd	Purpost/Result
										10-26-2021	SR	02		03	Cycl Insp Comp
										04-20-2020	WD			FR	Field Review
										02-16-2016	AL	03		16	In Office Review
										05-26-2010	PT	02		14	Cyclical Inspection

BUILDING PERMIT RECORD										LAND LINE VALUATION SECTION					
Permit Id	Issue Date	Type	Description	Amount	Insp Date	% Comp	Date Comp	Comments		Date	Id	Type	Is	Cd	Purpost/Result
19-333	01-31-2019	822	Insulation	4,000	06-30-2019	100	06-30-2019	Add R-13 fiberglass, R-30 cell		10-26-2021	SR	02		03	Cycl Insp Comp

B	Use Code	Description	Zone	LA	Land Units	Unit Price	Size Adj	AC Disc	Site Index	Cond.	Nbhd.	Nbhd. Adj	Notes	Location Adjustmen	Adj Unit P	Land Value
1	1010	Single Fam M-0	RC-	4	0.350 AC	176,344.00	2.46674	1.0000	5	1.00	0105	1.000		1.0000	434,987.7	152,200
Total Card Land Units					0.35	AC	Parcel Total Land Area					0.35	Total Land Value			152,200

CONSTRUCTION DETAIL			CONSTRUCTION DETAIL (CONTINUED)		
Element	Cd	Description	Element	Cd	Description
Style	08	Raised Ranch			
Model	01	Residential			
Grade:	C	Average			
Stories	1	1 Story			
Exterior Wall 1	14	Wood Shingle			
Exterior Wall 2	11	Clapboard			
Roof Structure	03	Gable/Hip			
Roof Cover	03	Asph/F Gls/Cmp			
Interior Wall 1	05	Drywall			
Interior Wall 2					
Interior Floor 1	14	Carpet			
Interior Floor 2					
Heat Fuel	03	Gas			
Heat Type	05	Hot Water			
AC Type	01	None			
Bedrooms	05	5 Bedrooms			
Full Baths	1				
Half Baths	0				
Extra Fixtures					
Total Rooms	9	9 Rooms			
Bath Style					
Kitchen Style					
Occupancy					
Usrflid 105					
Accessory Apt					
Foundation Alt	01	Poured Conc.			
Rms Prts					
Bath Split	10	1 Full-0 Half			

CONDO DATA			
Parcel Id		C	Owne 0.0
		B	S
Adjust Type	Code	Description	Factor%
Condo Flr			
Condo Unit			

COST / MARKET VALUATION	
Building Value New	333,679
Year Built	1970
Effective Year Built	1991
Depreciation Code	A
Remodel Rating	
Year Remodeled	
Depreciation %	22
Functional Obsol	0
External Obsol	0
Trend Factor	1
Condition	
Condition %	
Percent Good	78
RCNLD	260,300
Dep % Ovr	
Dep Ovr Comment	
Misc Imp Ovr	
Misc Imp Ovr Comment	
Cost to Cure Ovr	
Cost to Cure Ovr Comment	

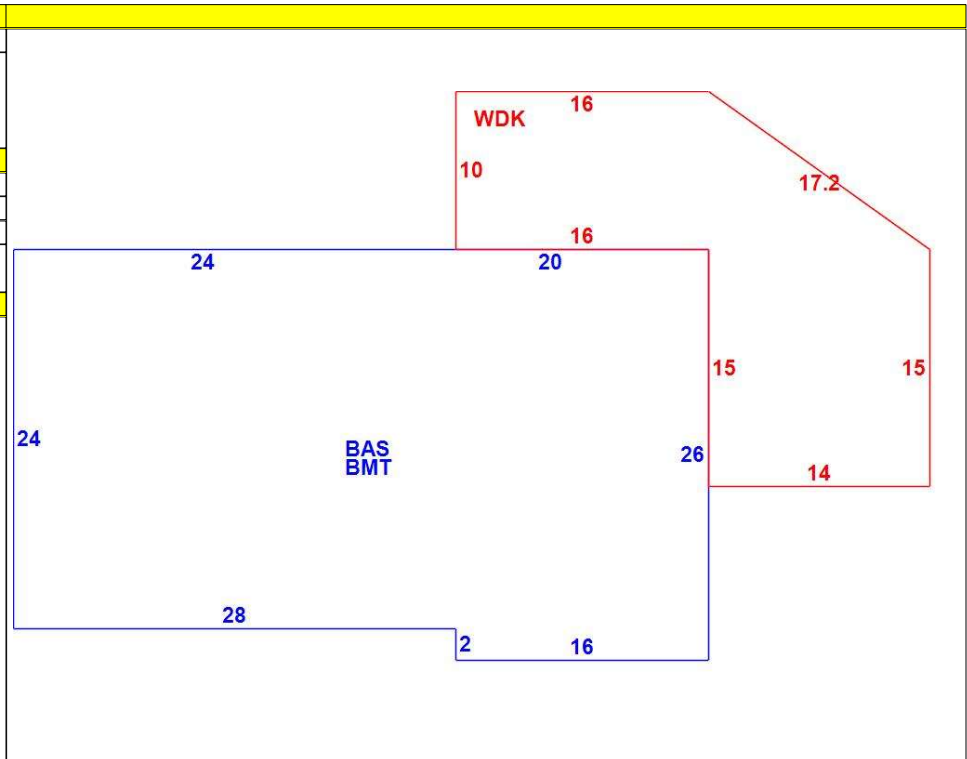

OB - OUTBUILDING & YARD ITEMS(L) / XF - BUILDING EXTRA FEATURES(B)										
Code	Description	L/B	Units	Unit Price	Yr Blt	Cond. Cd	% Gd	Grade	Grade Adj.	Appr. Value
FPL1	Fireplace 1 sto	B	1	5000.00	1993		78		0.00	3,900
BFA	Bsm't Fin-Avg	B	1,088	17.36	1993		78		0.00	14,700
WDC	Wood Decking	L	440	20.00	1995		52		0.00	4,400
BMT	Basement-Unfi	B	1,088	26.01	1993		78		0.00	21,900
SHED	Shed	L	128	18.00	2021		100		0.00	2,300

BUILDING SUB-AREA SUMMARY SECTION						
Code	Description	Living Area	Floor Area	Eff Area	Unit Cost	Undeprec Value
BAS	First Floor	1,088	1,088	1,088	306.69	333,679
BMT	Basement Area	0	1,088	0	0.00	0
WDC	Wood Deck	0	440	0	0.00	0
Ttl Gross Liv / Lease Area		1,088	2,616	1,088		333,679

