

CURRENT OWNER		TOPO	UTILITIES	STRT / ROAD	LOCATION	CURRENT ASSESSMENT				801 FY2024 BARNSTABLE, MA  <b>VISION</b>				
GREEN, RANDAL C & LEE, RICHARD ALAN & SHERRY GREEN IREV TRUS 101 CENTER LANE  CENTERVILLE MA 02632						Description	Code	Assessed	Assessed		RESIDNTL RES LAND	1010 1010	852,900 1,095,500	852,900 1,095,500
						<b>SUPPLEMENTAL DATA</b>								
Alt Prcl ID Split Zonin BID Parcel ResExpt Q #DL 1 LOTS, 7, 8 & 9 #DL 2 GIS ID F_976803_2706014				Plan Ref. 89/63 Land Ct# #SR Life Estate PP STATU Assoc Pid#										

RECORD OF OWNERSHIP		BK-VOL/PAGE	SALE DATE	Q/U	V/I	SALE PRIC	VC	PREVIOUS ASSESSMENTS (HISTORY)								
GREEN, RANDAL C & LEE, RICHARD G J		26671 0018	09-14-2012	U	I	1	1A	Year	Code	Assessed	Year	Code	Assessed	Year	Code	Assessed
GREEN, ALAN A & SHERRY R TRS		20234 0280	09-07-2005	U	I	1	1A	2023	1010	713,100	2022	1010	656,500	2021	1010	532,200
GREEN, ALAN A & SHERRY R		2036 0225	05-08-1974	U		0			1010	980,100		1010	515,200		1010	34,400
Total								1,693,200		Total		1,171,700		Total		1,081,800

EXEMPTIONS				OTHER ASSESSMENTS				This signature acknowledges a visit by a Data Collector or Assessor										
Year	Code	Description	Amount	Code	Description	Number	Amount	Comm Int										
Total			0.00															

ASSESSING NEIGHBORHOOD				APPRAISED VALUE SUMMARY										
Nbhd	Nbhd Name	B	Tracing	Batch										
0113			CENVIL											

NOTES													
Total Appraised Parcel Value										1,948,400			

BUILDING PERMIT RECORD									VISIT / CHANGE HISTORY					
Permit Id	Issue Date	Type	Description	Amount	Insp Date	% Comp	Date Comp	Comments	Date	Id	Type	Is	Cd	Purpost/Result
201506147	10-05-2015	IN	Insulation	4,583	06-30-2016	100	06-30-2016	AIR SEALING INSTALL 12" LA	04-20-2020	WD			FR	Field Review
20061658	07-03-2006	GN	Generator		06-30-2012	100	06-30-2012	GAS GENERATOR	03-01-2018	SR	02		03	Cycl Insp Comp
48716	09-18-2000	DW	Dwelling	433,000	04-11-2001	100	12-31-2001		03-03-2015	TR	03		16	In Office Review
48715	09-18-2000	DE	Demolish		04-11-2001	100	01-01-2001		09-20-2012	DR	22		22	Change of Address
B35320	08-01-1992	AD	Addition	15,700	01-15-1994	100	12-31-1994	CE ADD'N	03-01-2012	RB	03		16	In Office Review
									05-22-2009	NF	03		16	In Office Review
									03-26-2002	MF	01		00	Meas/Listed-Interior Acces

LAND LINE VALUATION SECTION																	
B	Use Code	Description	Zone	LA	Land Units	Unit Price	Size Adj	AC Disc	Site Index	Cond.	Nbhd.	Nbhd. Adj	Notes	Location Adjustmen	Adj Unit P	Land Value	
1	1010	Single Fam M-0	RD-	3	0.850 AC	176,344.00	1.16009	1.0000	5	1.00	0113	6.300	WEQUAQUET LAKE		1.0000	1,288,827	
Total Card Land Units					0.85	AC	Parcel Total Land Area					0.85	Total Land Value				1,095,500

CONSTRUCTION DETAIL			CONSTRUCTION DETAIL (CONTINUED)		
Element	Cd	Description	Element	Cd	Description
Style	02	Split-Level			
Model	01	Residential			
Grade:	B	Custom			
Stories	1	1 Story			
Exterior Wall 1	14	Wood Shingle			
Exterior Wall 2					
RooF Structure	03	Gable/Hip			
RooF Cover	03	Asph/F Gls/Cmp			
Interior Wall 1	03	Plastered			
Interior Wall 2					
Interior Floor 1	12	Hardwood			
Interior Floor 2	11	Ceram Clay Til			
Heat Fuel	03	Gas			
Heat Type	04	Hot Air			
AC Type	03	Central			
Bedrooms	04	4 Bedrooms			
Full Baths	3				
Half Baths	1				
Extra Fixtures					
Total Rooms	8	8 Rooms			
Bath Style					
Kitchen Style					
Occupancy					
Usrflid 105					
Accessory Apt					
Foundation Alt	01	Poured Conc.			
Rms Prts					
Bath Split	31	3 Full-1 Half			

CONDO DATA				
Parcel Id		C	Ownr	0.0
			B	S
Adjust Type	Code	Description	Factor%	
Condo Flr				
Condo Unit				

COST / MARKET VALUATION		
Building Value New		790,295
Year Built		2000
Effective Year Built		2006
Depreciation Code		A
Remodel Rating		
Year Remodeled		
Depreciation %		10
Functional Obsol		0
External Obsol		0
Trend Factor		1
Condition		
Condition %		
Percent Good		90
RCNLD		711,300
Dep % Ovr		
Dep Ovr Comment		
Misc Imp Ovr		
Misc Imp Ovr Comment		
Cost to Cure Ovr		
Cost to Cure Ovr Comment		

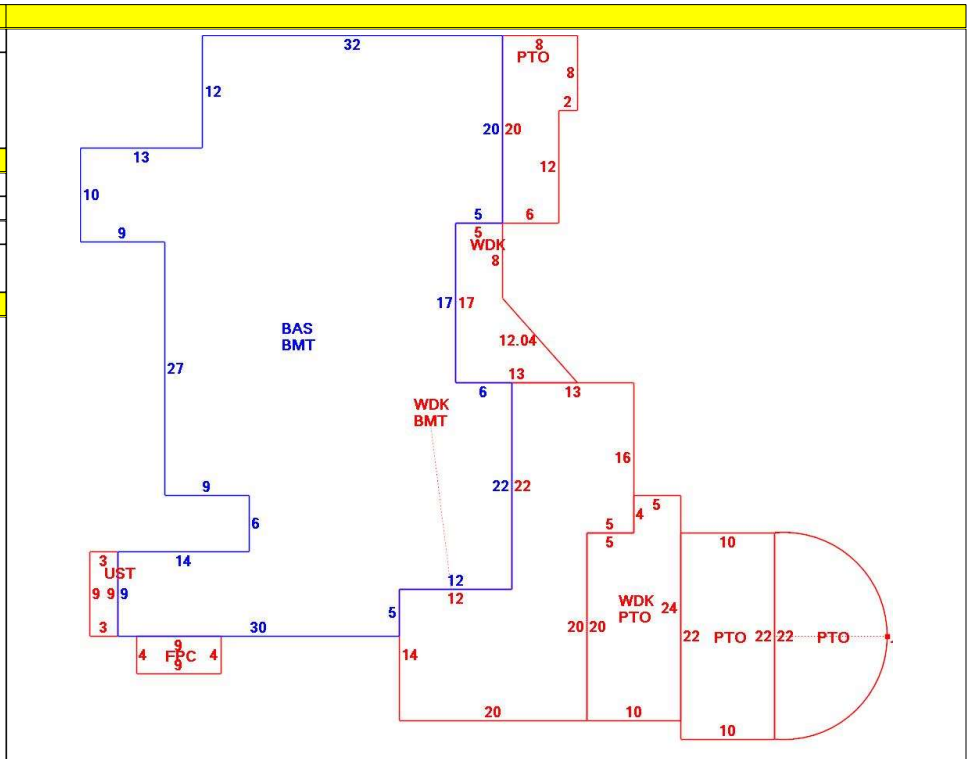

OB - OUTBUILDING & YARD ITEMS(L) / XF - BUILDING EXTRA FEATURES(B)										
Code	Description	L/B	Units	Unit Price	Yr Blt	Cond. Cd	% Gd	Grade	Grade Adj.	Appr. Value
FPL1	Fireplace 1 sto	B	2	5000.00	2008		90		0.00	9,000
BFA1	Bsmt Fin-Goo	B	1,478	32.56	2008		90		0.00	43,300
WDC	Wood Decking	L	877	20.00	2005		72		0.00	11,400
PATS	Patio-Concrete	L	653	20.00	2005		86		0.00	10,600
FOPC	Open Prch-roo	B	36	55.00	2008		90		0.00	2,100
UST	Utility Storage-	B	27	17.11	2008		90		0.00	500
BMT	Basement-Unfi	B	2,755	26.01	2008		90		0.00	52,300
DKPL	Pond Dock-Lig	L	1	4200.00	2000		100		0.00	4,200
GEN	Emergency Ge	L	1	5550.00	2006		74		0.00	4,100
PATF	Flagstone Pav	L	136	30.00	2005		86		0.00	4,100

BUILDING SUB-AREA SUMMARY SECTION						
Code	Description	Living Area	Floor Area	Eff Area	Unit Cost	Undeprec Value
BAS	First Floor	2,219	2,219	2,219	356.15	790,295
BMT	Basement Area	0	2,755	0	0.00	0
FPC	Open Porch Conc. Floor	0	36	0	0.00	0
PTO	Patio	0	789	0	0.00	0
UST	Utility Enclosure	0	27	0	0.00	0
WDK	Wood Deck	0	877	0	0.00	0
Ttl Gross Liv / Lease Area		2,219	6,703	2,219		790,295

