

CURRENT OWNER		TOPO	UTILITIES	STRT / ROAD	LOCATION	CURRENT ASSESSMENT			
PARAGHAMIAN, HAROLD A & EUGENIA EUGENIA, TRS 237 MOCKINGBIRD LANE MARSTONS MIL MA 02648		1 Level	2 Public Water	1 Paved		Description	Code	Assessed	Assessed
			4 Gas			RESIDNTL	1010	488,700	488,700
			6 Septic			RES LAND	1010	156,200	156,200
SUPPLEMENTAL DATA						Total			
Alt Prcl ID Split Zonin BID Parcel ResExpt Q YES: #DL 1 LOT 137 #DL 2 GIS ID F_943622_2705644				Plan Ref. 284/91 Land Ct# #SR Life Estate PP STATU Assoc Pid#		644,900			

801
 FY2024
 BARNSTABLE, MA

VISION

RECORD OF OWNERSHIP		BK-VOL/PAGE	SALE DATE	Q/U	V/I	SALE PRIC	VC	PREVIOUS ASSESSMENTS (HISTORY)					
PARAGHAMIAN, HAROLD A & EUGENIA	22638	0166	01-31-2008	U	I	1	1A	Year	Code	Assessed	Year	Code	Assessed
PARAGHAMIAN, HAROLD A & EUGENIA	21124	0034	06-23-2006	Q	I	450,000	00	2023	1010	431,800	2022	1010	360,300
HARRINGTON, KEVIN J & KATHRYN M	17620	0038	09-10-2003	Q	I	420,000	00		1010	142,000		1010	105,200
BAKER, MARK L & CAROLA	3794	0315	07-11-1983	Q	I	54,200	U					1010	7,600
GREENBRIER CORP	3648	0093	01-15-1983	U	V	30,000	N	Total		573,800	Total		465,500
								Total		410,400	Total		410,400

EXEMPTIONS				OTHER ASSESSMENTS			
Year	Code	Description	Amount	Code	Description	Number	Amount
2022	5C	RESIDENTIAL EXEMPTION					
Total			0.00				

This signature acknowledges a visit by a Data Collector or Assessor

ASSESSING NEIGHBORHOOD			
Nbhd	Nbhd Name	B	Tracing
0105			MARSTM

NOTES			

APPRAISED VALUE SUMMARY	
Appraised Bldg. Value (Card)	444,200
Appraised Xf (B) Value (Bldg)	31,300
Appraised Ob (B) Value (Bldg)	13,200
Appraised Land Value (Bldg)	156,200
Special Land Value	0
Total Appraised Parcel Value	644,900
Valuation Method	C
Total Appraised Parcel Value	644,900

BUILDING PERMIT RECORD									VISIT / CHANGE HISTORY					
Permit Id	Issue Date	Type	Description	Amount	Insp Date	% Comp	Date Comp	Comments	Date	Id	Type	Is	Cd	Purpost/Result
201302101	04-04-2013	NS	New Siding	12,500	06-30-2013	100	06-30-2013	RESIDE	12-19-2022	DB	02		03	Cycl Insp Comp
20647	01-23-1997	AD	Addition	38,500	12-02-1997	100	01-01-1997		07-30-2021	LH	03		16	In Office Review
B24892	03-01-1983	DW	Dwelling	0	01-15-1984	100	01-15-1984	MM 1STORY	02-24-2021	CK	22		22	Change of Address
									05-20-2020	LS				FR
									09-15-2014	SR	02		03	Cycl Insp Comp
									08-14-2014	JR	03		16	In Office Review

LAND LINE VALUATION SECTION																
B	Use Code	Description	Zone	LA	Land Units	Unit Price	Size Adj	AC Disc	Site Index	Cond.	Nbhd.	Nbhd. Adj	Notes	Location Adjustmen	Adj Unit P	Land Value
1	1010	Single Fam M-0	RF	3	0.470	AC	176,344.00	1.88432	1.0000	5	1.00	0105	1.000		1.0000	332,285
Total Card Land Units					0.47	AC	Parcel Total Land Area					0.47	Total Land Value			156,200

CONSTRUCTION DETAIL			CONSTRUCTION DETAIL (CONTINUED)		
Element	Cd	Description	Element	Cd	Description
Style	04	Cape Cod			
Model	01	Residential			
Grade:	C	Average			
Stories	1.66				
Exterior Wall 1	14	Wood Shingle			
Exterior Wall 2	25	Vinyl Siding			
Roof Structure	03	Gable/Hip			
Roof Cover	03	Asph/F Gls/Cmp			
Interior Wall 1	05	Drywall			
Interior Wall 2					
Interior Floor 1	14	Carpet			
Interior Floor 2	12	Hardwood			
Heat Fuel	03	Gas			
Heat Type	04	Hot Air			
AC Type	03	Central			
Bedrooms	04	4 Bedrooms			
Full Baths	2				
Half Baths	1				
Extra Fixtures					
Total Rooms	10	10 Rooms			
Bath Style					
Kitchen Style					
Occupancy					
Usrflid 105					
Accessory Apt					
Foundation Alt	01	Poured Conc.			
Rms Prts					
Bath Split	21	2 Full-1 Half			

CONDO DATA			
Parcel Id	C	Owne	0.0
Adjust Type	Code	Description	Factor%
Condo Flr	Condo Unit		

COST / MARKET VALUATION	
Building Value New	535,126
Year Built	1983
Effective Year Built	1997
Depreciation Code	A
Remodel Rating	
Year Remodeled	
Depreciation %	17
Functional Obsol	0
External Obsol	0
Trend Factor	1
Condition	
Condition %	
Percent Good	83
RCNLD	444,200
Dep % Ovr	
Dep Ovr Comment	
Misc Imp Ovr	
Misc Imp Ovr Comment	
Cost to Cure Ovr	
Cost to Cure Ovr Comment	

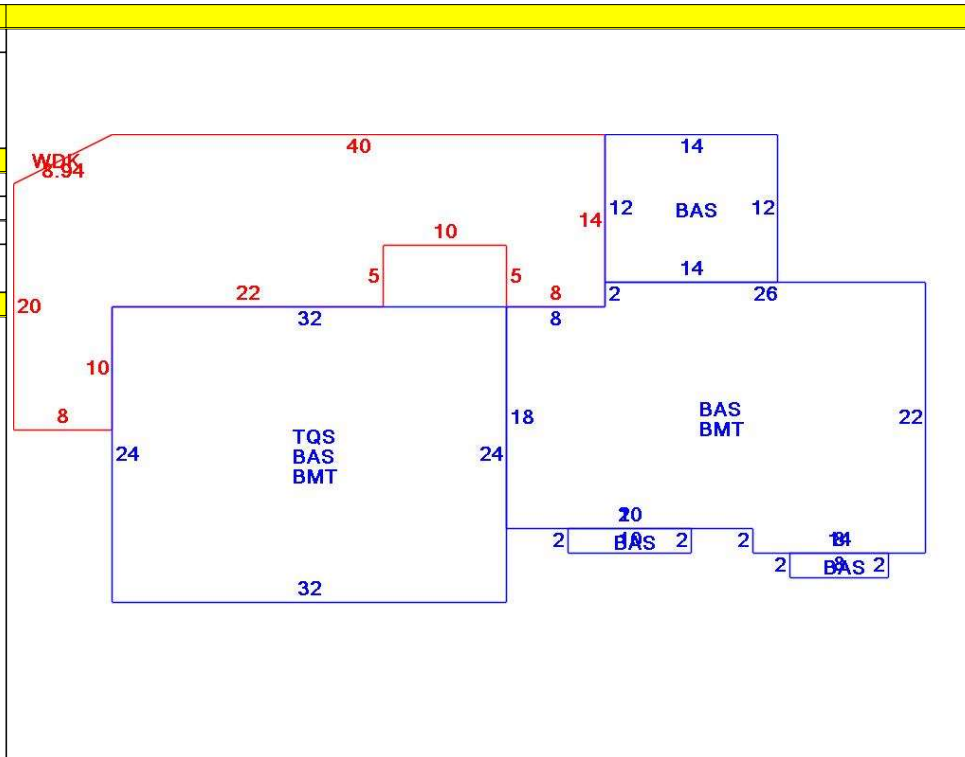

OB - OUTBUILDING & YARD ITEMS(L) / XF - BUILDING EXTRA FEATURES(B)										
Code	Description	L/B	Units	Unit Price	Yr Blt	Cond. Cd	% Gd	Grade	Grade Adj.	Appr. Value
BFA	Bsmt Fin-Avg	B	168	17.36	1999		83		0.00	2,400
WDC	Wood Decking	L	686	20.00	1993		48		0.00	6,000
BMT	Basement-Unfi	B	1,460	26.01	1999		83		0.00	28,900
SHD2	Shed w/Elec	L	120	26.00	1994		50		0.00	1,600
GEN	Emergency Ge	L	1	5550.00	2022		100		0.00	5,600

BUILDING SUB-AREA SUMMARY SECTION						
Code	Description	Living Area	Floor Area	Eff Area	Unit Cost	Undeprec Value
BAS	First Floor	1,664	1,664	1,664	247.40	411,674
BMT	Basement Area	0	1,460	0	0.00	0
TQS	Three Quarter Story	499	768	499	160.75	123,453
WDC	Wood Deck	0	686	0	0.00	0
Ttl Gross Liv / Lease Area		2,163	4,578	2,163		535,127

