

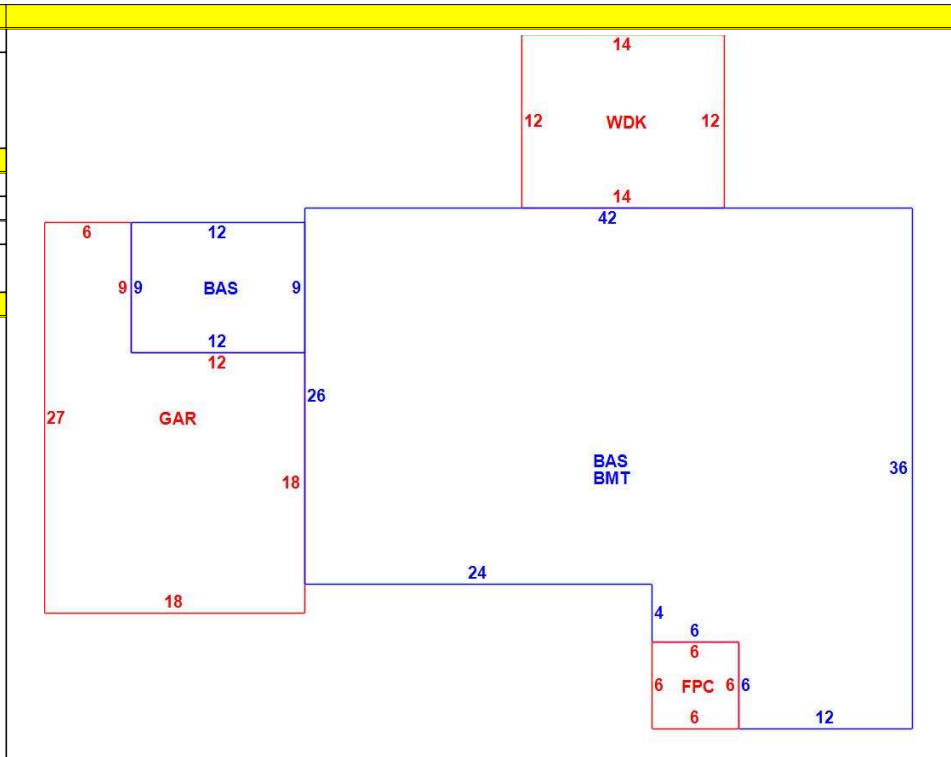

CONSTRUCTION DETAIL			CONSTRUCTION DETAIL (CONTINUED)		
Element	Cd	Description	Element	Cd	Description
Style	01	Ranch			
Model	01	Residential			
Grade:	C+	Average Plus			
Stories	1	1 Story			
Exterior Wall 1	14	Wood Shingle			
Exterior Wall 2	25	Vinyl Siding			
RooF Structure	03	Gable/Hip			
RooF Cover	03	Asph/F Gls/Cmp			
Interior Wall 1	05	Drywall			
Interior Wall 2					
Interior Floor 1	12	Hardwood			
Interior Floor 2					
Heat Fuel	03	Gas			
Heat Type	04	Hot Air			
AC Type	01	None			
Bedrooms	03	3 Bedrooms			
Full Baths	2				
Half Baths	0				
Extra Fixtures					
Total Rooms	6	6 Rooms			
Bath Style					
Kitchen Style					
Occupancy					
UsrflD 105					
Accessory Apt					
Foundation Alt	01	Poured Conc.			
Rms Prts					
Bath Split	20	2 Full-0 Half			

CONDO DATA				
Parcel Id		C	Ownr	0.0
Adjust Type	Code	Description	Factor%	
Condo Flr				
Condo Unit				

COST / MARKET VALUATION		
Building Value New		409,709
Year Built		1963
Effective Year Built		1997
Depreciation Code		VG
Remodel Rating		
Year Remodeled		
Depreciation %		17
Functional Obsol		0
External Obsol		0
Trend Factor		1
Condition		
Condition %		
Percent Good		83
RCNLD		340,100
Dep % Ovr		
Dep Ovr Comment		
Misc Imp Ovr		
Misc Imp Ovr Comment		
Cost to Cure Ovr		
Cost to Cure Ovr Comment		



OB - OUTBUILDING & YARD ITEMS(L) / XF - BUILDING EXTRA FEATURES(B)										
Code	Description	L/B	Units	Unit Price	Yr Blt	Cond. Cd	% Gd	Grade	Grade Adj.	Appr. Value
FPL1	Fireplace 1 sto	B	1	5000.00	1999		83		0.00	4,200
WDC	Wood Decking	L	168	20.00	1999		60		0.00	2,600
FOPC	Open Prch-roo	B	36	55.00	1999		83		0.00	1,900
GAR	Attached Gara	B	378	40.00	1999		83		0.00	12,900
BMT	Basement-Unfi	B	1,236	26.01	1999		83		0.00	25,400

BUILDING SUB-AREA SUMMARY SECTION						
Code	Description	Living Area	Floor Area	Eff Area	Unit Cost	Undeprec Value
BAS	First Floor	1,344	1,344	1,344	304.84	409,709
BMT	Basement Area	0	1,236	0	0.00	0
FPC	Open Porch Conc. Floor	0	36	0	0.00	0
GAR	Attached Garage	0	378	0	0.00	0
WDC	Wood Deck	0	168	0	0.00	0
Ttl Gross Liv / Lease Area		1,344	3,162	1,344		409,709

