

CURRENT OWNER		TOPO	UTILITIES	STRT / ROAD	LOCATION	CURRENT ASSESSMENT			
BROWN, PATRICIA A & CHARLOTTE 888 PHINNEY'S LANE CENTERVILLE MA 02632		1 Level	2 Public Water	1 Paved		Description	Code	Assessed	Assessed
			4 Gas			RESIDNTL	1010	259,000	259,000
			6 Septic			RES LAND	1010	151,900	151,900
SUPPLEMENTAL DATA						Total 410,900 410,900			
Alt Prcl ID		Split Zonin RC-1;RD-1		Plan Ref. Land Ct# 30367-A (SH 2)					
BID Parcel		ResExpt Q		#SR					
#DL 1 LOT 24		#DL 2		Life Estate PP STATU					
GIS ID F_978166_2706539		Assoc Pid#							

801
 FY2024
 BARNSTABLE, MA

VISION

RECORD OF OWNERSHIP		BK-VOL/PAGE	SALE DATE	Q/U	V/I	SALE PRIC	VC	PREVIOUS ASSESSMENTS (HISTORY)						
BROWN, PATRICIA A & CHARLOTTE A II		C211535	0	12-07-2016	Q	I	200,000	00	Year	Code	Assessed	Year	Code	Assessed
LOUNSBERY, ANNE ELIZABETH		C164526	0	03-11-2002	U	I	100	1A	2023	1010	229,800	2022	1010	193,100
LOUNSBERY, ANN & ALLEN B		93P1114F	0	04-14-1994	U	I	0	1A		1010	138,100		1010	102,300
LOUNSBERY, RUTH A		C77434	0	03-15-1979	Q	V	29,500	00	Total		367,900	Total		295,400
				Total						Total				267,100

EXEMPTIONS			OTHER ASSESSMENTS					
Year	Code	Description	Amount	Code	Description	Number	Amount	Comm Int
Total			0.00					

This signature acknowledges a visit by a Data Collector or Assessor

ASSESSING NEIGHBORHOOD				APPRAISED VALUE SUMMARY		
Nbhd	Nbhd Name	B	Tracing	Batch		
0105				CENVIL		
NOTES					Appraised Bldg. Value (Card)	230,800
					Appraised Xf (B) Value (Bldg)	28,200
					Appraised Ob (B) Value (Bldg)	0
					Appraised Land Value (Bldg)	151,900
					Special Land Value	0
					Total Appraised Parcel Value	410,900
					Valuation Method	C
					Total Appraised Parcel Value	410,900

BUILDING PERMIT RECORD									VISIT / CHANGE HISTORY					
Permit Id	Issue Date	Type	Description	Amount	Insp Date	% Comp	Date Comp	Comments	Date	Id	Type	Is	Cd	Purpost/Result
17-758	03-22-2017	822	Insulation	3,500	06-30-2017	100	06-30-2017	Weatherization	11-02-2021	SR	02		03	Cycl Insp Comp
201503190	05-28-2015	NR	New Roof	3,500	06-30-2015	100	06-30-2016	RE-ROOF (STRIPPING OLD)	04-20-2020	WD			FR	Field Review
									01-31-2017	JR	03		20	Sale Review
									01-23-2017	AL	22		22	Change of Address
									02-21-2014	JR	03		16	In Office Review
									01-25-2001	PT	01		00	Meas/Listed-Interior Acces
									10-15-1989	ML	01		00	Meas/Listed-Interior Acces

LAND LINE VALUATION SECTION																	
B	Use Code	Description	Zone	LA	Land Units	Unit Price	Size Adj	AC Disc	Site Index	Cond.	Nbhd.	Nbhd. Adj	Notes	Location Adjustmen	Adj Unit P	Land Value	
1	1010	Single Fam M-0	SPLI	3	0.340	AC	176,344.00	2.53383	1.0000	5	1.00	0105	1.000		1.0000	446,820.4	151,900
Total Card Land Units					0.34	AC	Parcel Total Land Area					0.34	Total Land Value			151,900	

CONSTRUCTION DETAIL			CONSTRUCTION DETAIL (CONTINUED)		
Element	Cd	Description	Element	Cd	Description
Style	04	Cape Cod			
Model	01	Residential			
Grade:	C	Average			
Stories	1.75	1 3/4 Stories			
Exterior Wall 1	14	Wood Shingle			
Exterior Wall 2					
RooF Structure	03	Gable/Hip			
RooF Cover	03	Asph/F Gls/Cmp			
Interior Wall 1	03	Plastered			
Interior Wall 2	05	Drywall			
Interior Floor 1	14	Carpet			
Interior Floor 2					
Heat Fuel	03	Gas			
Heat Type	05	Hot Water			
AC Type	01	None			
Bedrooms	02	2 Bedrooms			
Full Baths	1				
Half Baths	1				
Extra Fixtures					
Total Rooms	5	5 Rooms			
Bath Style					
Kitchen Style					
Occupancy					
UsrflD 105					
Accessory Apt					
Foundation Alt	02	Conc. Block			
Rms Prts					
Bath Split	11	1 Full-1 Half			

CONDO DATA				
Parcel Id		C		Owne 0.0
			B	S
Adjust Type	Code	Description	Factor%	
Condo Flr				
Condo Unit				

COST / MARKET VALUATION	
Building Value New	355,071
Year Built	1930
Effective Year Built	1974
Depreciation Code	F
Remodel Rating	
Year Remodeled	
Depreciation %	35
Functional Obsol	0
External Obsol	0
Trend Factor	1
Condition	
Condition %	
Percent Good	65
RCNLD	230,800
Dep % Ovr	
Dep Ovr Comment	
Misc Imp Ovr	
Misc Imp Ovr Comment	
Cost to Cure Ovr	
Cost to Cure Ovr Comment	

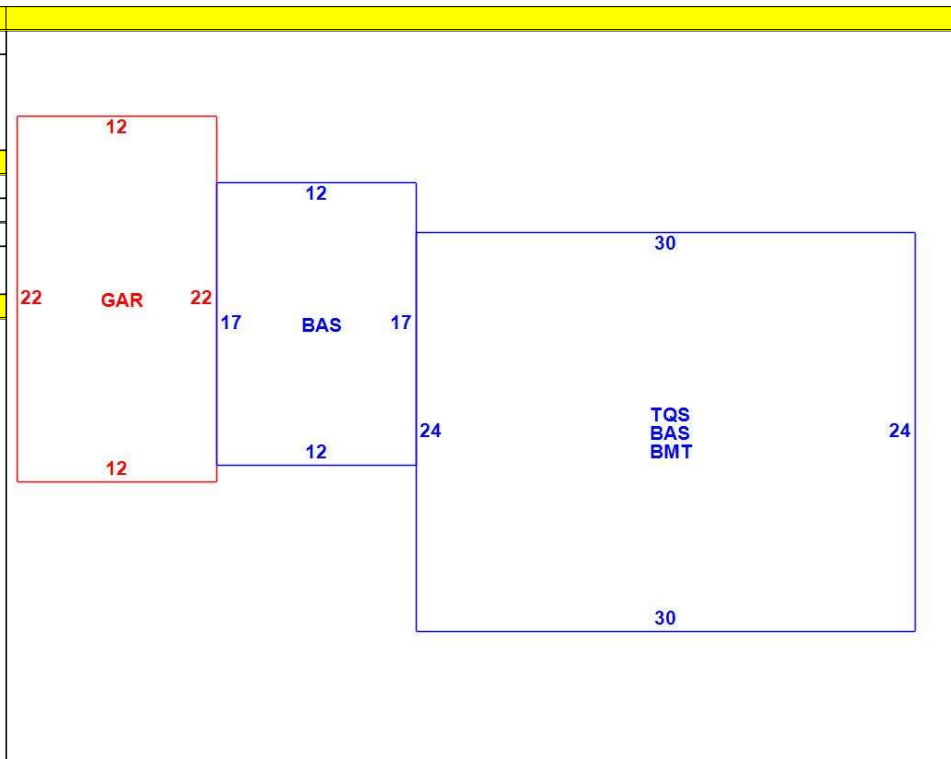

OB - OUTBUILDING & YARD ITEMS(L) / XF - BUILDING EXTRA FEATURES(B)										
Code	Description	L/B	Units	Unit Price	Yr Blt	Cond. Cd	% Gd	Grade	Grade Adj.	Appr. Value
FPL2	Fireplace 1.5 s	B	1	6000.00	1974		65		0.00	3,900
GAR	Attached Gara	B	264	40.00	1974		65		0.00	7,900
BMT	Basement-Unfi	B	924	26.01	1974		65		0.00	16,400

BUILDING SUB-AREA SUMMARY SECTION						
Code	Description	Living Area	Floor Area	Eff Area	Unit Cost	Undeprec Value
BAS	First Floor	924	924	924	255.08	235,694
BMT	Basement Area	0	720	0	0.00	0
GAR	Attached Garage	0	264	0	0.00	0
TQS	Three Quarter Story	468	720	468	165.80	119,377
Ttl Gross Liv / Lease Area		1,392	2,628	1,392		355,071

