

CURRENT OWNER		TOPO	UTILITIES	STRT / ROAD	LOCATION	CURRENT ASSESSMENT			
FLYNN, EDWARD P & KATHLEEN I 23 LAURA ROAD CENTERVILLE MA 02632		1 Level	2 Public Water	1 Paved		Description	Code	Assessed	Assessed
			4 Gas			RESIDENTL	1010	367,900	367,900
			6 Septic			RES LAND	1010	147,800	147,800
SUPPLEMENTAL DATA									
Alt Prcl ID		Split Zonin RC-1;RD-1		Plan Ref. Land Ct# 30367-A					
BID Parcel		ResExpt Q		#SR					
#DL 1 LOT 15				Life Estate PP STATU					
#DL 2				Assoc Pid#					
GIS ID F_977925_2705546						Total 515,700 515,700			

801
 FY2024
 BARNSTABLE, MA

VISION

RECORD OF OWNERSHIP		BK-VOL/PAGE	SALE DATE	Q/U	V/I	SALE PRIC	VC	PREVIOUS ASSESSMENTS (HISTORY)						
FLYNN, EDWARD P & KATHLEEN I		C176846	0	05-31-2005	Q	I	391,000	00	Year	Code	Assessed	Year	Code	Assessed
ADAMS, ROBERT A & JUDY M		C51833	0	07-07-1971	U		0		2023	1010	330,800	2022	1010	278,500
										1010	134,400		1010	99,500
													1010	2,600
									Total		465,200	Total		378,000
									Total			Total		340,500

EXEMPTIONS			OTHER ASSESSMENTS					
Year	Code	Description	Amount	Code	Description	Number	Amount	Comm Int
Total			0.00					

This signature acknowledges a visit by a Data Collector or Assessor

ASSESSING NEIGHBORHOOD			
Nbhd	Nbhd Name	B	Tracing
0105			CENVIL

BUILDING PERMIT RECORD									VISIT / CHANGE HISTORY					
Permit Id	Issue Date	Type	Description	Amount	Insp Date	% Comp	Date Comp	Comments	Date	Id	Type	Is	Cd	Purpost/Result
16-1388	06-16-2016	839	Solar Panel-Re	9,724	08-16-2016	100	06-30-2017	Install roof mounted pv solar s	04-21-2020	WD			FR	Field Review
201006225	11-23-2010	RE	Remodel	11,400	06-30-2011	100	06-30-2011	BTHRM REMOD, SAME LAY	04-10-2017	JR	02		02	Bldg Permit Completed
B32442	11-01-1988	AD	Addition	10,000	02-15-1989	100	12-31-1989	CE ADD'N	04-14-2014	JR	03		16	In Office Review
									04-06-2011	NF	03		02	Bldg Permit Completed
									06-07-2010	PT	02		14	Cyclical Inspection
									01-12-2006	PT	02		49	N/C - Cyclical Insp.
									10-03-2005	JK	22		22	Change of Address

LAND LINE VALUATION SECTION																	
B	Use Code	Description	Zone	LA	Land Units	Unit Price	Size Adj	AC Disc	Site Index	Cond.	Nbhd.	Nbhd. Adj	Notes	Location Adjustmen	Adj Unit P	Land Value	
1	1010	Single Fam M-0	SPLI	3	0.240	AC	176,344.00	3.49265	1.0000	5	1.00	0105	1.000		1.0000	615,916.6	147,800
Total Card Land Units					0.24	AC	Parcel Total Land Area					0.24	Total Land Value			147,800	

CONSTRUCTION DETAIL			CONSTRUCTION DETAIL (CONTINUED)		
Element	Cd	Description	Element	Cd	Description
Style	04	Cape Cod			
Model	01	Residential			
Grade:	C	Average			
Stories	1.75	1 3/4 Stories			
Exterior Wall 1	14	Wood Shingle			
Exterior Wall 2	11	Clapboard			
RooF Structure	03	Gable/Hip			
RooF Cover	03	Asph/F Gls/Cmp			
Interior Wall 1	05	Drywall			
Interior Wall 2					
Interior Floor 1	14	Carpet			
Interior Floor 2	05	Vinyl/Asphalt			
Heat Fuel	03	Gas			
Heat Type	05	Hot Water			
AC Type	01	None			
Bedrooms	04	4 Bedrooms			
Full Baths	2				
Half Baths	0				
Extra Fixtures					
Total Rooms	8	8 Rooms			
Bath Style					
Kitchen Style					
Occupancy					
Usrflid 105					
Accessory Apt					
Foundation Alt	01	Poured Conc.			
Rms Prts					
Bath Split	20	2 Full-0 Half			

CONDO DATA				
Parcel Id		C		Ownr 0.0
			B	S
Adjust Type	Code	Description	Factor%	
Condo Flr				
Condo Unit				

COST / MARKET VALUATION	
Building Value New	396,047
Year Built	1971
Effective Year Built	1996
Depreciation Code	G
Remodel Rating	
Year Remodeled	
Depreciation %	18
Functional Obsol	0
External Obsol	0
Trend Factor	1
Condition	
Condition %	
Percent Good	82
RCNLD	324,800
Dep % Ovr	
Dep Ovr Comment	
Misc Imp Ovr	
Misc Imp Ovr Comment	
Cost to Cure Ovr	
Cost to Cure Ovr Comment	

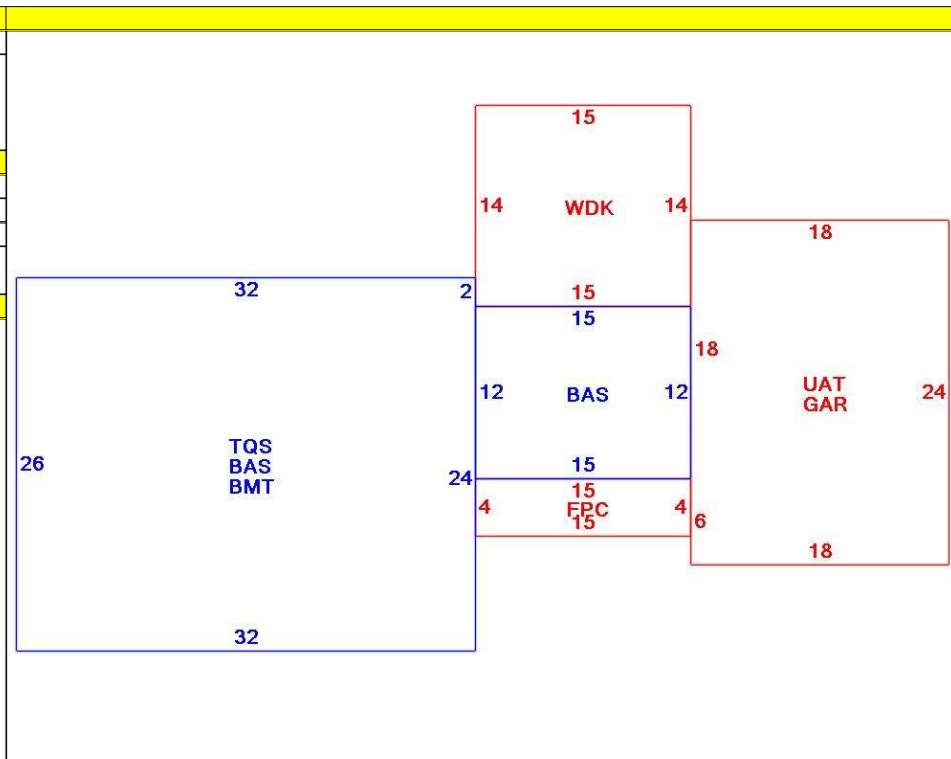

OB - OUTBUILDING & YARD ITEMS(L) / XF - BUILDING EXTRA FEATURES(B)										
Code	Description	L/B	Units	Unit Price	Yr Blt	Cond. Cd	% Gd	Grade	Grade Adj.	Appr. Value
FPL2	Fireplace 1.5 s	B	1	6000.00	1998		82		0.00	4,900
WDC	Wood Decking	L	210	20.00	1996		54		0.00	2,600
FOPC	Open Prch-roo	B	60	55.00	1998		82		0.00	2,700
GAR	Attached Gara	B	432	40.00	1998		82		0.00	13,800
BMT	Basement-Unfi	B	832	26.01	1998		82		0.00	19,100
SOL1	Solar PV Pane	B	17	860.00	1998		0		0.00	0

BUILDING SUB-AREA SUMMARY SECTION						
Code	Description	Living Area	Floor Area	Eff Area	Unit Cost	Undeprec Value
BAS	First Floor	1,012	1,012	1,012	248.15	251,128
BMT	Basement Area	0	832	0	0.00	0
FPC	Open Porch Conc. Floor	0	60	0	0.00	0
GAR	Attached Garage	0	432	0	0.00	0
TQS	Three Quarter Story	541	832	541	161.36	134,249
UAT	Attic, Unfinished	0	432	43	24.70	10,670
WDK	Wood Deck	0	210	0	0.00	0
Ttl Gross Liv / Lease Area		1,553	3,810	1,596		396,047

