

CURRENT OWNER		TOPO	UTILITIES	STRT / ROAD	LOCATION	CURRENT ASSESSMENT			
MULDOON-ELLSWORTH, JANET & J  16 EAST VIEW DR  SIMSBURY CT 06070		3 Below Street	2 Public Water	1 Paved	1 Lake/Pond Fro	Description	Code	Assessed	Assessed
			4 Gas		1 Excel View	RESIDNTL	1010	119,000	119,000
			6 Septic			RES LAND	1010	819,400	819,400
<b>SUPPLEMENTAL DATA</b>									
Alt Prcl ID Split Zonin BID Parcel ResExpt Q #DL 1 LOT 52 #DL 2 GIS ID F_977653_2707645				Plan Ref. 21/93 Land Ct# #SR Life Estate PP STATU Assoc Pid#		Total 938,400 938,400			

801  
 FY2024  
 BARNSTABLE, MA

**VISION**

RECORD OF OWNERSHIP		BK-VOL/PAGE	SALE DATE	Q/U	V/I	SALE PRIC	VC	PREVIOUS ASSESSMENTS (HISTORY)					
MULDOON-ELLSWORTH, JANET & JOAN	20382	0236	10-20-2005	U	I	1	1A	Year	Code	Assessed	Year	Code	Assessed
MULDOON, PERSIS S ESTATE OF	7875	0048	02-15-1992	U	I	1	A	2023	1010	116,700	2022	1010	83,000
MULDOON, PERSIS S TR	7388	0008	12-15-1990	U	I	1	A		1010	677,200		1010	441,400
MULDOON, PERSIS S	0461	0550	02-23-1929	U		0		Total		793,900	Total		524,400
								Total		484,300	Total		484,300

EXEMPTIONS			OTHER ASSESSMENTS					
Year	Code	Description	Amount	Code	Description	Number	Amount	Comm Int
		Total	0.00					

This signature acknowledges a visit by a Data Collector or Assessor

ASSESSING NEIGHBORHOOD			
Nbhd	Nbhd Name	B	Tracing
0112			CENVIL

APPRAISED VALUE SUMMARY	
Appraised Bldg. Value (Card)	92,300
Appraised Xf (B) Value (Bldg)	9,300
Appraised Ob (B) Value (Bldg)	17,400
Appraised Land Value (Bldg)	819,400
Special Land Value	0
Total Appraised Parcel Value	938,400
Valuation Method	C
Total Appraised Parcel Value	938,400

BUILDING PERMIT RECORD								VISIT / CHANGE HISTORY						
Permit Id	Issue Date	Type	Description	Amount	Insp Date	% Comp	Date Comp	Comments	Date	Id	Type	Is	Cd	Purpost/Result
18558	06-11-1996	AD	Addition	4,500	01-01-1997	100		10x12 WD	04-21-2020	WD			FR	Field Review
15757	06-10-1996	AD	Addition	3,500	01-01-1997	100		9 x 10 WD	01-20-2017	KM	02		03	Cycl Insp Comp
									10-20-2000	PT	01		00	Meas/Listed-Interior Acces

LAND LINE VALUATION SECTION																	
B	Use Code	Description	Zone	LA	Land Units	Unit Price	Size Adj	AC Disc	Site Index	Cond.	Nbhd.	Nbhd. Adj	Notes	Location Adjustmen	Adj Unit P	Land Value	
1	1010	Single Fam M-0	RD-	3	0.250 AC	176,344.00	3.37919	1.0000	5	1.00	0112	5.500	WEQUAQUET LAKE		1.0000	3,277,441	819,400
Total Card Land Units					0.25	AC	Parcel Total Land Area					0.25	Total Land Value			819,400	

CONSTRUCTION DETAIL			CONSTRUCTION DETAIL (CONTINUED)		
Element	Cd	Description	Element	Cd	Description
Style	36	Cottage			
Model	01	Residential			
Grade:	C	Average			
Stories	1	1 Story			
Exterior Wall 1	14	Wood Shingle			
Exterior Wall 2					
RooF Structure	03	Gable/Hip			
RooF Cover	03	Asph/F Gls/Cmp			
Interior Wall 1	05	Drywall			
Interior Wall 2					
Interior Floor 1	14	Carpet			
Interior Floor 2					
Heat Fuel	08	Propane			
Heat Type	01	None			
AC Type	01	None			
Bedrooms	02	2 Bedrooms			
Full Baths	2				
Half Baths	0				
Extra Fixtures					
Total Rooms	4	4 Rooms			
Bath Style					
Kitchen Style					
Occupancy					
Usrflid 105					
Accessory Apt					
Foundation Alt	09	Blk/Pour Ftgs			
Rms Prts					
Bath Split	20	2 Full-0 Half			

CONDO DATA			
Parcel Id		C	Ownr 0.0
		B	S
Adjust Type	Code	Description	Factor%
Condo Flr			
Condo Unit			

COST / MARKET VALUATION	
Building Value New	126,424
Year Built	1929
Effective Year Built	1984
Depreciation Code	G
Remodel Rating	
Year Remodeled	
Depreciation %	27
Functional Obsol	0
External Obsol	0
Trend Factor	1
Condition	
Condition %	
Percent Good	73
RCNLD	92,300
Dep % Ovr	
Dep Ovr Comment	
Misc Imp Ovr	
Misc Imp Ovr Comment	
Cost to Cure Ovr	
Cost to Cure Ovr Comment	

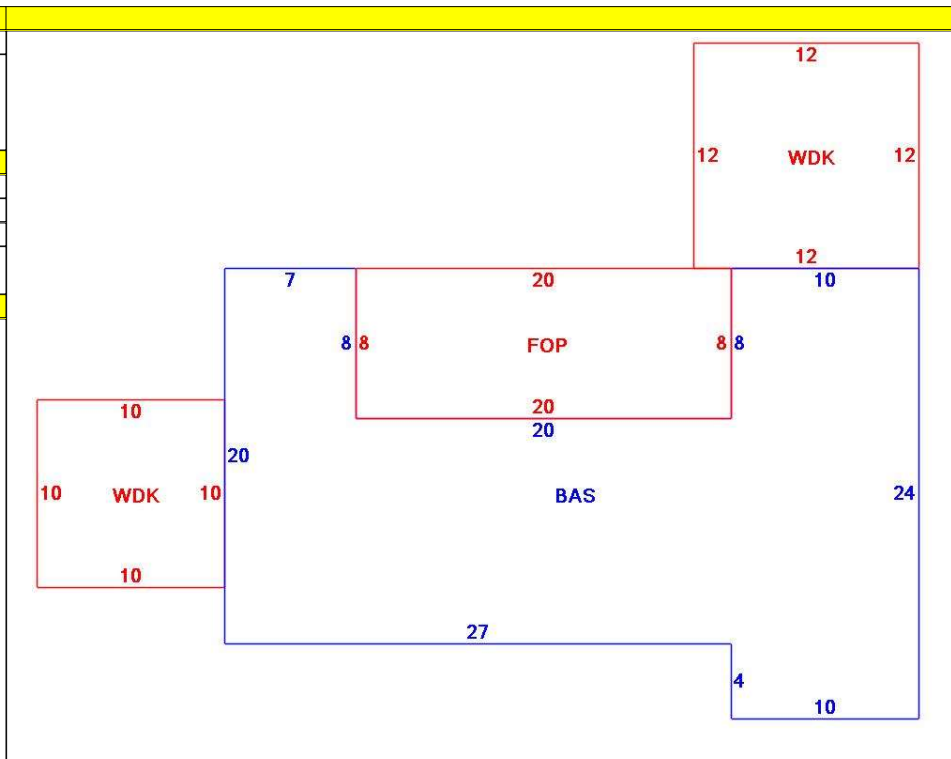

OB - OUTBUILDING & YARD ITEMS(L) / XF - BUILDING EXTRA FEATURES(B)										
Code	Description	L/B	Units	Unit Price	Yr Blt	Cond. Cd	% Gd	Grade	Grade Adj.	Appr. Value
FPL1	Fireplace 1 sto	B	1	5000.00	1984		73		0.00	3,700
DKPA	Pond Dock-Av	L	1	32500.00	1993		48		0.00	15,600
WDC	Wood Decking	L	244	20.00	1986		34		0.00	1,800
FOP	Open Porch-ro	B	160	55.00	1984		73		0.00	5,600

BUILDING SUB-AREA SUMMARY SECTION						
Code	Description	Living Area	Floor Area	Eff Area	Unit Cost	Undeprec Value
BAS	First Floor	620	620	620	203.91	126,424
FOP	Open Porch	0	160	0	0.00	0
WDK	Wood Deck	0	244	0	0.00	0
Ttl Gross Liv / Lease Area		620	1,024	620		126,424

