



CONSTRUCTION DETAIL			CONSTRUCTION DETAIL (CONTINUED)		
Element	Cd	Description	Element	Cd	Description
Style	01	Ranch			
Model	01	Residential			
Grade:	C+	Average Plus			
Stories	1	1 Story			
Exterior Wall 1	14	Wood Shingle			
Exterior Wall 2	11	Clapboard			
RooF Structure	03	Gable/Hip			
RooF Cover	03	Asph/F Gls/Cmp			
Interior Wall 1	05	Drywall			
Interior Wall 2					
Interior Floor 1	14	Carpet			
Interior Floor 2	12	Hardwood			
Heat Fuel	03	Gas			
Heat Type	04	Hot Air			
AC Type	03	Central			
Bedrooms	03	3 Bedrooms			
Full Baths	2				
Half Baths	0				
Extra Fixtures					
Total Rooms	7	7 Rooms			
Bath Style					
Kitchen Style					
Occupancy					
Usrflid 105					
Accessory Apt					
Foundation Alt	01	Poured Conc.			
Rms Prts					
Bath Split	20	2 Full-0 Half			

CONDO DATA				
Parcel Id		C	Owne	0.0
Adjust Type	Code	Description	Factor%	
Condo Flr				
Condo Unit				

COST / MARKET VALUATION		
Building Value New		542,171
Year Built		1995
Effective Year Built		2008
Depreciation Code		G
Remodel Rating		
Year Remodeled		
Depreciation %		9
Functional Obsol		0
External Obsol		0
Trend Factor		1
Condition		
Condition %		
Percent Good		91
RCNLD		493,400
Dep % Ovr		
Dep Ovr Comment		
Misc Imp Ovr		
Misc Imp Ovr Comment		
Cost to Cure Ovr		
Cost to Cure Ovr Comment		

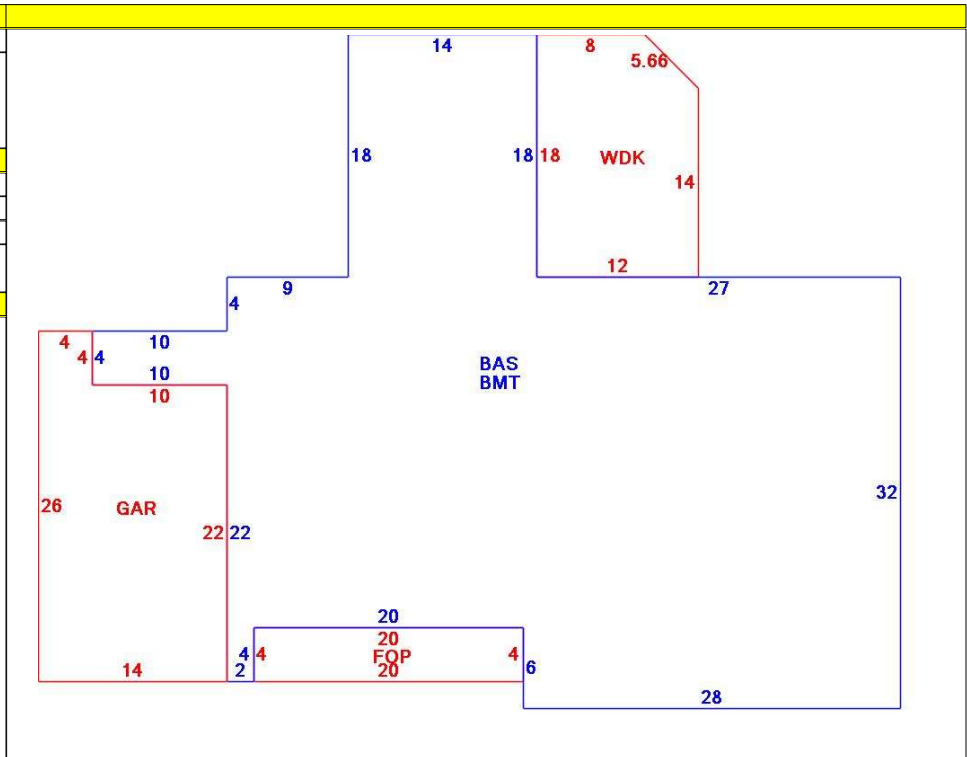

OB - OUTBUILDING & YARD ITEMS(L) / XF - BUILDING EXTRA FEATURES(B)										
Code	Description	L/B	Units	Unit Price	Yr Blt	Cond. Cd	% Gd	Grade	Grade Adj.	Appr. Value
FPL1	Fireplace 1 sto	B	1	5000.00	2010		91		0.00	4,600
WDC	Deck comp w	L	208	28.00	2003		68		0.00	4,600
FOP	Open Porch-ro	B	80	55.00	2010		91		0.00	4,300
GAR	Attached Gara	B	324	40.00	2010		91		0.00	12,800
BMT	Basement-Unfi	B	1,768	26.01	2010		91		0.00	36,700
SHED	Shed	L	96	18.00	2016		94		0.00	1,600

BUILDING SUB-AREA SUMMARY SECTION						
Code	Description	Living Area	Floor Area	Eff Area	Unit Cost	Undeprec Value
BAS	First Floor	1,768	1,768	1,768	306.66	542,171
BMT	Basement Area	0	1,768	0	0.00	0
FOP	Open Porch	0	80	0	0.00	0
GAR	Attached Garage	0	324	0	0.00	0
WDK	Wood Deck	0	208	0	0.00	0
Ttl Gross Liv / Lease Area		1,768	4,148	1,768		542,171

