

CURRENT OWNER		TOPO	UTILITIES	STRT / ROAD	LOCATION	CURRENT ASSESSMENT				801 FY2024 BARNSTABLE, MA
JUDGE, DORIS M TR DORIS JUDGE REVOC TRUST AGMT 624 LAKE ORCHID CIRCLE		1 Level	6 Septic	1 Paved		Description	Code	Assessed	Assessed	
			4 Gas			RESIDNTL	1010	529,500	529,500	
VERO BEACH FL 32960		SUPPLEMENTAL DATA				RES LAND	1010	259,400	259,400	<b>VISION</b>
		Alt Prcl ID	Plan Ref.	Land Ct#	36669-C (SH 2)					
		Split Zonin		#SR						
		BID Parcel		Life Estate						
		ResExpt Q		PP STATU						
		#DL 1 LOT 42		Assoc Pid#						
		#DL 2								
		GIS ID F_978882_2708450				Total	788,900	788,900		

RECORD OF OWNERSHIP		BK-VOL/PAGE	SALE DATE	Q/U	V/I	SALE PRIC	VC	PREVIOUS ASSESSMENTS (HISTORY)					
JUDGE, DORIS M TR	C207101	0	08-12-2015	U	I	1	1F	Year	Code	Assessed	Year	Code	Assessed
JUDGE, DORIS	#D12759	0	08-12-2015	U	I	0	1A	2023	1010	475,100	2022	1010	399,000
JUDGE, WILLIAM J & DORIS	C159474	0	10-24-2000	Q	I	353,750	00		1010	256,600	2021	1010	164,400
RUSSELL, BERNARD	C156995	0	03-23-2000	U	I	331,000	1						
DACEY, BRIAN T TR	C134960	0	09-12-1994	U	V	100	B						
								Total	731,700	Total	563,400	Total	518,900

EXEMPTIONS			OTHER ASSESSMENTS				This signature acknowledges a visit by a Data Collector or Assessor								
Year	Code	Description	Amount	Code	Description	Number	Amount	Comm Int							
		Total	0.00												

ASSESSING NEIGHBORHOOD				APPRAISED VALUE SUMMARY			
Nbhd	Nbhd Name	B	Tracing	Batch			
0108				HYAN	Appraised Bldg. Value (Card)	472,300	
					Appraised Xf (B) Value (Bldg)	53,300	
					Appraised Ob (B) Value (Bldg)	3,900	
					Appraised Land Value (Bldg)	259,400	
					Special Land Value	0	
					Total Appraised Parcel Value	788,900	
					Valuation Method	C	
					Total Appraised Parcel Value	788,900	

BUILDING PERMIT RECORD								VISIT / CHANGE HISTORY						
Permit Id	Issue Date	Type	Description	Amount	Insp Date	% Comp	Date Comp	Comments	Date	Id	Type	Is	Cd	Purpost/Result
40086	07-30-1999	DW	Dwelling	101,750	05-26-2000	100	01-01-2000		04-21-2020	WD			FR	Field Review
									10-11-2016	KM	02		03	Cycl Insp Comp
									08-05-2014	JR	03		16	In Office Review
									10-12-2011	RB	03		16	In Office Review
									05-04-2010	NF	03		16	In Office Review
									05-04-2010	NF	03		16	In Office Review
									10-05-2000	PT	01		00	Meas/Listed-Interior Acces

LAND LINE VALUATION SECTION																		
B	Use Code	Description	Zone	LA	Land Units	Unit Price	Size Adj	AC Disc	Site Index	Cond.	Nbhd.	Nbhd. Adj	Notes	Location Adjustmen	Adj Unit P	Land Value		
1	1010	Single Fam M-0	RC-	4	0.360 AC	176,344.00	2.40337	1.0000	5	1.00	0108	1.700		1.0000	720,488.6	259,400		
					Total Card Land Units	0.36 AC						Parcel Total Land Area	0.36				Total Land Value	259,400

CONSTRUCTION DETAIL			CONSTRUCTION DETAIL (CONTINUED)		
Element	Cd	Description	Element	Cd	Description
Style	04	Cape Cod			
Model	01	Residential			
Grade:	C+	Average Plus			
Stories	1.75	1 3/4 Stories			
Exterior Wall 1	14	Wood Shingle			
Exterior Wall 2					
RooF Structure	03	Gable/Hip			
RooF Cover	03	Asph/F Gls/Cmp			
Interior Wall 1	05	Drywall			
Interior Wall 2					
Interior Floor 1	12	Hardwood			
Interior Floor 2					
Heat Fuel	03	Gas			
Heat Type	04	Hot Air			
AC Type	03	Central			
Bedrooms	03	3 Bedrooms			
Full Baths	2				
Half Baths	1				
Extra Fixtures					
Total Rooms	6	6 Rooms			
Bath Style					
Kitchen Style					
Occupancy					
Usrflid 105					
Accessory Apt					
Foundation Alt	01	Poured Conc.			
Rms Prts					
Bath Split	21	2 Full-1 Half			
<b>CONDO DATA</b>			<b>COST / MARKET VALUATION</b>		
Parcel Id		C	Owne	0.0	
Adjust Type	Code	Description	Factor%		
Condo Flr					
Condo Unit					
Building Value New			530,672		
Year Built			1999		
Effective Year Built			2005		
Depreciation Code			A		
Remodel Rating					
Year Remodeled					
Depreciation %			11		
Functional Obsol			0		
External Obsol			0		
Trend Factor			1		
Condition					
Condition %					
Percent Good			89		
RCNLD			472,300		
Dep % Ovr					
Dep Ovr Comment					
Misc Imp Ovr					
Misc Imp Ovr Comment					
Cost to Cure Ovr					
Cost to Cure Ovr Comment					

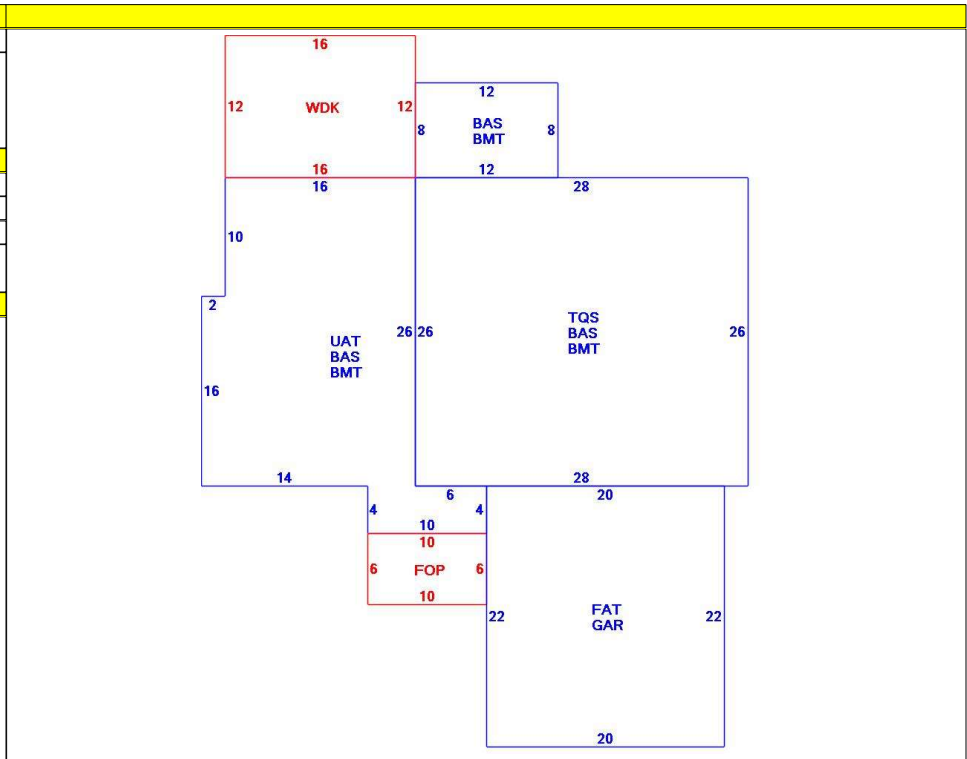

OB - OUTBUILDING & YARD ITEMS(L) / XF - BUILDING EXTRA FEATURES(B)										
Code	Description	L/B	Units	Unit Price	Yr Blt	Cond. Cd	% Gd	Grade	Grade Adj.	Appr. Value
FPL2	Fireplace 1.5 s	B	1	6000.00	2007		89		0.00	5,300
WDC	Wood Decking	L	256	20.00	2005		72		0.00	3,900
FOP	Open Porch-ro	B	60	55.00	2007		89		0.00	3,400
GAR	Attached Gara	B	440	40.00	2007		89		0.00	15,200
BMT	Basement-Unfi	B	1,360	26.01	2007		89		0.00	29,400

BUILDING SUB-AREA SUMMARY SECTION						
Code	Description	Living Area	Floor Area	Eff Area	Unit Cost	Undeprec Value
BAS	First Floor	1,312	1,312	1,312	279.30	366,443
BMT	Basement Area	0	1,312	0	0.00	0
FAT	Attic, Finished	66	440	66	41.90	18,434
FOP	Open Porch	0	60	0	0.00	0
GAR	Attached Garage	0	440	0	0.00	0
TQS	Three Quarter Story	473	728	473	181.47	132,109
UAT	Attic, Unfinished	0	488	49	28.04	13,686
WDK	Wood Deck	0	192	0	0.00	0
Ttl Gross Liv / Lease Area		1,851	4,972	1,900		530,672

