

CURRENT OWNER		TOPO	UTILITIES	STRT / ROAD	LOCATION	CURRENT ASSESSMENT			
KENNEDY, STACEY A TR OLCOTT FAMILY IRREVOCABLE TRU 37 CRESTVIEW CIRCLE CENTERVILLE MA 02632		1 Level	6 Septic	1 Paved		Description	Code	Assessed	Assessed
			4 Gas			RESIDNTL	1010	531,200	531,200
			2 Public Water			RES LAND	1010	251,300	251,300
SUPPLEMENTAL DATA									
		Alt Prcl ID Split Zonin BID Parcel ResExpt Q #DL 1 LOT 52 #DL 2 GIS ID F_978696_2708435		Plan Ref. 505/78 Land Ct# #SR Life Estate PP STATU Assoc Pid#		Total 782,500 782,500			

801
 FY2024
 BARNSTABLE, MA

VISION

RECORD OF OWNERSHIP		BK-VOL/PAGE	SALE DATE	Q/U	V/I	SALE PRIC	VC	PREVIOUS ASSESSMENTS (HISTORY)								
KENNEDY, STACEY A TR OLCOTT, JACK R & JUDITH E DACEY, BRIAN T TR		29504 0174	03-11-2016	U	I	10	1A	Year	Code	Assessed	Year	Code	Assessed			
		12659 0026	11-12-1999	U	I	271,000	1	2023	1010	460,900	2022	1010	394,500			
		C134765 0	08-15-1994	U	V	1,024,000	B		1010	248,600	2021	1010	159,300			
								Total		709,500	Total		553,800	Total		491,200

EXEMPTIONS			OTHER ASSESSMENTS						
Year	Code	Description	Amount	Code	Description	Number	Amount	Comm Int	
		Total	0.00					This signature acknowledges a visit by a Data Collector or Assessor	

ASSESSING NEIGHBORHOOD				APPRAISED VALUE SUMMARY		
Nbhd	Nbhd Name	B	Tracing	Batch		
0108				HYAN		
NOTES					Appraised Bldg. Value (Card)	473,700
					Appraised Xf (B) Value (Bldg)	54,200
					Appraised Ob (B) Value (Bldg)	3,300
					Appraised Land Value (Bldg)	251,300
					Special Land Value	0
					Total Appraised Parcel Value	782,500
					Valuation Method	C
					Total Appraised Parcel Value	782,500

BUILDING PERMIT RECORD									VISIT / CHANGE HISTORY						
Permit Id	Issue Date	Type	Description	Amount	Insp Date	% Comp	Date Comp	Comments	Date	Id	Type	Is	Cd	Purpost/Result	
18-985	04-20-2018	822	Insulation	6,225	06-30-2019	100	06-30-2019	Insulation & Air Sealing.	11-05-2021	SR	02		03	Cycl Insp Comp	
88410	11-15-2005	AD	Addition	45,000	10-10-2006	100	06-30-2007		04-21-2020	WD				FR	Field Review
39341	06-24-1999	DW	Dwelling	84,700	05-26-2000	100	01-01-2000		03-14-2007	JG	03			52	New Construction
									10-10-2006	MF	02			02	Bldg Permit Completed
									03-29-2006	MF	02			13	CALL BACK
									10-05-2000	PT	01			00	Meas/Listed-Interior Acces
									05-26-2000	DD	02			01	Meas/Est

LAND LINE VALUATION SECTION																	
B	Use Code	Description	Zone	LA	Land Units	Unit Price	Size Adj	AC Disc	Site Index	Cond.	Nbhd.	Nbhd. Adj	Notes	Location Adjustmen	Adj Unit P	Land Value	
1	1010	Single Fam M-0	RC-	4	0.240 AC	176,344.00	3.49265	1.0000	5	1.00	0108	1.700	SPLIT FD		1.0000	1,047,042	251,300
Total Card Land Units					0.24	AC	Parcel Total Land Area					0.24	Total Land Value				251,300

CONSTRUCTION DETAIL			CONSTRUCTION DETAIL (CONTINUED)		
Element	Cd	Description	Element	Cd	Description
Style	01	Ranch			
Model	01	Residential			
Grade:	C+	Average Plus			
Stories	1	1 Story			
Exterior Wall 1	14	Wood Shingle			
Exterior Wall 2	11	Clapboard			
RooF Structure	03	Gable/Hip			
RooF Cover	03	Asph/F Gls/Cmp			
Interior Wall 1	05	Drywall			
Interior Wall 2					
Interior Floor 1	12	Hardwood			
Interior Floor 2					
Heat Fuel	03	Gas			
Heat Type	04	Hot Air			
AC Type	03	Central			
Bedrooms	03	3 Bedrooms			
Full Baths	2				
Half Baths	0				
Extra Fixtures					
Total Rooms	6	6 Rooms			
Bath Style					
Kitchen Style					
Occupancy					
UsrflD 105					
Accessory Apt					
Foundation Alt	01	Poured Conc.			
Rms Prts					
Bath Split	20	2 Full-0 Half			
CONDO DATA			COST / MARKET VALUATION		
Parcel Id		C	Owne	0.0	
Adjust Type	Code	Description	Factor%		
Condo Flr					
Condo Unit					
Building Value New		532,205			
Year Built		1999			
Effective Year Built		2005			
Depreciation Code		A			
Remodel Rating					
Year Remodeled					
Depreciation %		11			
Functional Obsol		0			
External Obsol		0			
Trend Factor		1			
Condition					
Condition %					
Percent Good		89			
RCNLD		473,700			
Dep % Ovr					
Dep Ovr Comment					
Misc Imp Ovr					
Misc Imp Ovr Comment					
Cost to Cure Ovr					
Cost to Cure Ovr Comment					

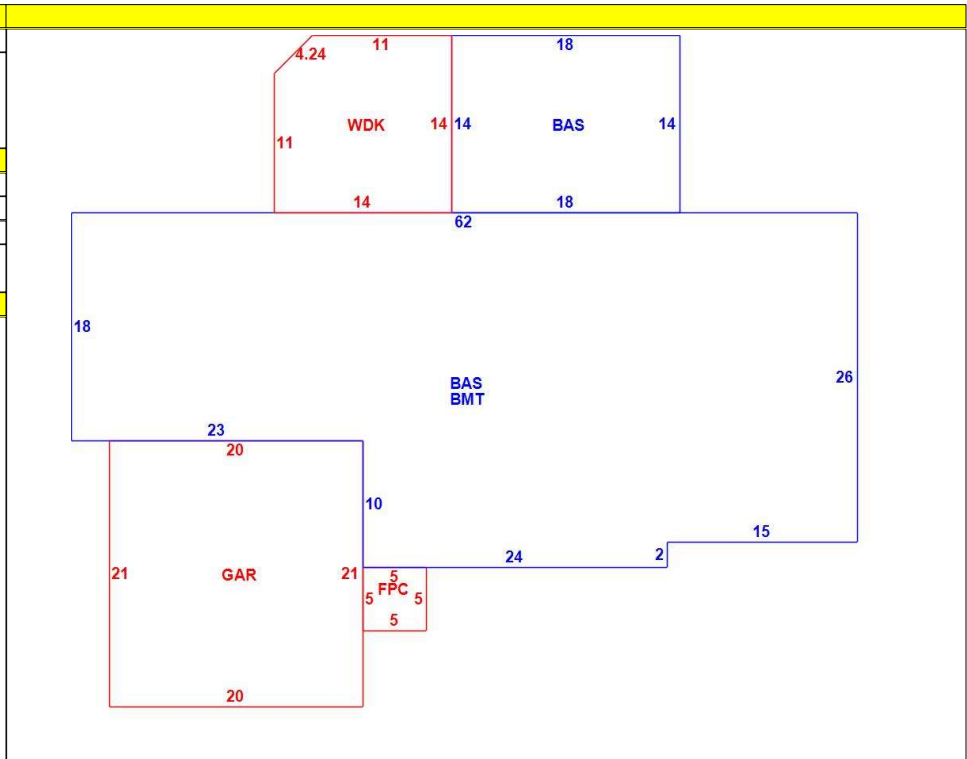

OB - OUTBUILDING & YARD ITEMS(L) / XF - BUILDING EXTRA FEATURES(B)										
Code	Description	L/B	Units	Unit Price	Yr Blt	Cond. Cd	% Gd	Grade	Grade Adj.	Appr. Value
FPL1	Fireplace 1 sto	B	1	5000.00	2007		89		0.00	4,500
WDC	Wood Decking	L	192	20.00	2005		72		0.00	3,300
FOPC	Open Prch-roo	B	25	55.00	2007		89		0.00	1,600
GAR	Attached Gara	B	420	40.00	2007		89		0.00	14,700
BMT	Basement-Unfi	B	1,476	26.01	2007		89		0.00	31,200
FPLG	Gas Fireplace-	B	1	2500.00	2007		89		0.00	2,200

BUILDING SUB-AREA SUMMARY SECTION						
Code	Description	Living Area	Floor Area	Eff Area	Unit Cost	Undeprec Value
BAS	First Floor	1,728	1,728	1,728	307.99	532,205
BMT	Basement Area	0	1,476	0	0.00	0
FPC	Open Porch Conc. Floor	0	25	0	0.00	0
GAR	Attached Garage	0	420	0	0.00	0
WDK	Wood Deck	0	192	0	0.00	0
Ttl Gross Liv / Lease Area		1,728	3,841	1,728		532,205

