

| CURRENT OWNER | | TOPO | | UTILITIES | | STRT / ROAD | | LOCATION | | CURRENT ASSESSMENT | | | | 801 FY2024 BARNSTABLE, MA VISION | | | | | | | |
|--|------------|-----------------------|-------------|-------------------|--------------|-------------|------------------------|---|------------|-------------------------------|-------|--------------------------------|------------------|--|----------------------------|----------------------|--------------|--------------------|--------------------|------|----------|
| PATRICK, LESLIE G & MIYA T P O BOX 432 BARNSTABLE MA 02630 | | 1 | Level | 2 | Public Water | 1 | Paved | | | Description | Code | Assessed | Assessed | | | RESIDNTL RES LAND | 1010 1010 | 736,600 327,700 | 736,600 327,700 | | |
| | | | | 4 | Gas | | | | | | | | | | | | | | | | |
| | | | | 6 | Septic | | | | | | | | | | | | | | | | |
| SUPPLEMENTAL DATA | | | | | | | | | | Total | | 1,064,300 | 1,064,300 | | | | | | | | |
| Alt Prcl ID | | Split Zonin | | Plan Ref. | | Land Ct# | | | | | | | | | | | | | | | |
| BID Parcel | | ResExpt Q YES: | | Life Estate | | PP STATU | | | | | | | | | | | | | | | |
| #DL 1 | | | | Assoc Pid# | | | | | | | | | | | | | | | | | |
| #DL 2 | | | | | | | | | | | | | | | | | | | | | |
| GIS ID | | F_978266_2719629 | | | | | | | | | | | | | | | | | | | |
| RECORD OF OWNERSHIP | | | | BK-VOL/PAGE | | SALE DATE | | Q/U V/I | | SALE PRIC | | VC | | PREVIOUS ASSESSMENTS (HISTORY) | | | | | | | |
| PATRICK, LESLIE G & MIYA T | | | | 3816 | 0169 | 08-15-1983 | | Q | I | 125,000 | | U | Year | Code | Assessed | Year | Code | Assessed | Year | Code | Assessed |
| | | | | | | | | | | | | | 2023 | 1010 | 624,500 | 2022 | 1010 | 505,800 | 2021 | 1010 | 449,400 |
| | | | | | | | | | | | | | | 1010 | 304,700 | | 1010 | 210,700 | | 1010 | 230,700 |
| | | | | | | | | | | | | | | | | | | | | 1010 | 7,000 |
| | | | | | | | | | | | | | Total | | 929,200 | Total | | 716,500 | Total | | 687,100 |
| EXEMPTIONS | | | | OTHER ASSESSMENTS | | | | This signature acknowledges a visit by a Data Collector or Assessor | | | | | | | | | | | | | |
| Year | Code | Description | | Amount | | Code | Description | Number | Amount | Comm Int | | | | | | | | | | | |
| 2010 | 5C | RESIDENTIAL EXEMPTION | | 0.00 | | | | | | | | | | | | | | | | | |
| Total | | | | 0.00 | | | | | | | | | | | | | | | | | |
| ASSESSING NEIGHBORHOOD | | | | | | | | | | | | APPRAISED VALUE SUMMARY | | | | | | | | | |
| Nbhd | | Nbhd Name | | B | | Tracing | | Batch | | Appraised Bldg. Value (Card) | | | | 692,400 | | | | | | | |
| 0109 | | | | | | | | BARNs | | Appraised Xf (B) Value (Bldg) | | | | 37,200 | | | | | | | |
| | | | | | | | | | | | | Appraised Ob (B) Value (Bldg) | | 7,000 | | | | | | | |
| | | | | | | | | | | | | Appraised Land Value (Bldg) | | 327,700 | | | | | | | |
| | | | | | | | | | | | | Special Land Value | | 0 | | | | | | | |
| | | | | | | | | | | | | Total Appraised Parcel Value | | 1,064,300 | | | | | | | |
| | | | | | | | | | | | | Valuation Method | | C | | | | | | | |
| | | | | | | | | | | | | Total Appraised Parcel Value | | 1,064,300 | | | | | | | |
| BUILDING PERMIT RECORD | | | | | | | | | | VISIT / CHANGE HISTORY | | | | | | | | | | | |
| Permit Id | Issue Date | Type | Description | Amount | Insp Date | % Comp | Date Comp | Comments | | Date | Id | Type | Is | Cd | Purpost/Result | | | | | | |
| 12528 | 12-29-1995 | SH | Shed | 5,000 | 01-01-1997 | 100 | 01-01-1997 | SHEDS | | 05-12-2020 | DM | | | FR | Field Review | | | | | | |
| 12528A | 12-01-1995 | SH | Shed | 5,000 | 01-15-1996 | 100 | 06-30-1996 | BA SHED | | 03-13-2017 | JR | 03 | | 03 | Cycl Insp Comp | | | | | | |
| B34081 | 11-01-1990 | AD | Addition | 5,000 | 01-15-1991 | 100 | 06-30-1991 | BA DORMER | | 07-21-2015 | JR | 03 | | 16 | In Office Review | | | | | | |
| B27714 | 04-01-1985 | AD | Addition | 13,000 | 01-15-1987 | 100 | 06-30-1987 | BA 1 STOR | | 05-19-2008 | TP | 03 | | 16 | In Office Review | | | | | | |
| | | | | | | | | | | 07-07-2006 | JR | 03 | | 15 | Abatement Review | | | | | | |
| | | | | | | | | | | 08-29-2000 | PT | 01 | | 00 | Meas/Listed-Interior Acces | | | | | | |
| | | | | | | | | | | 01-15-1991 | ME | 02 | | 01 | Meas/Est | | | | | | |
| LAND LINE VALUATION SECTION | | | | | | | | | | | | | | | | | | | | | |
| B | Use Code | Description | Zone | LA | Land Units | Unit Price | Size Adj | AC Disc | Site Index | Cond. | Nbhd. | Nbhd. Adj | Notes | Location Adjustmen | Adj Unit P | Land Value | | | | | |
| 1 | 1010 | Single Fam M-0 | R-2 | 1 | 0.250 | AC | 176,344.00 | 3.37919 | 1.0000 | 5 | 1.00 | 0109 | 2.200 | | 1.0000 | 1,310,976 | 327,700 | | | | |
| Total Card Land Units | | | | | 0.25 | AC | Parcel Total Land Area | | | | | 0.25 | Total Land Value | | | | | 327,700 | | | |

| CONSTRUCTION DETAIL | | | CONSTRUCTION DETAIL (CONTINUED) | | |
|---------------------|----|----------------|---------------------------------|----|-------------|
| Element | Cd | Description | Element | Cd | Description |
| Style | 03 | Colonial | | | |
| Model | 01 | Residential | | | |
| Grade: | C+ | Average Plus | | | |
| Stories | 2 | 2 Stories | | | |
| Exterior Wall 1 | 14 | Wood Shingle | | | |
| Exterior Wall 2 | | | | | |
| Roof Structure | 03 | Gable/Hip | | | |
| Roof Cover | 10 | Wood Shingle | | | |
| Interior Wall 1 | 03 | Plastered | | | |
| Interior Wall 2 | | | | | |
| Interior Floor 1 | 09 | Pine/Soft Wood | | | |
| Interior Floor 2 | | | | | |
| Heat Fuel | 03 | Gas | | | |
| Heat Type | 04 | Hot Air | | | |
| AC Type | 01 | None | | | |
| Bedrooms | 05 | 5 Bedrooms | | | |
| Full Baths | 3 | | | | |
| Half Baths | 0 | | | | |
| Extra Fixtures | | | | | |
| Total Rooms | 14 | 14 Rooms | | | |
| Bath Style | | | | | |
| Kitchen Style | | | | | |
| Occupancy | | | | | |
| Usrflid 105 | | | | | |
| Accessory Apt | | | | | |
| Foundation Alt | 11 | Stone Ftgs | | | |
| Rms Prts | | | | | |
| Bath Split | 30 | 3 Full-0 Half | | | |

| CONDO DATA | | | | |
|-------------|------|-------------|---------|----------|
| Parcel Id | | C | | Ownr 0.0 |
| Adjust Type | Code | Description | Factor% | |
| Condo Flr | | | | |
| Condo Unit | | | | |

| COST / MARKET VALUATION | | |
|--------------------------|--|---------|
| Building Value New | | 899,248 |
| Year Built | | 1802 |
| Effective Year Built | | 1989 |
| Depreciation Code | | VG |
| Remodel Rating | | |
| Year Remodeled | | |
| Depreciation % | | 23 |
| Functional Obsol | | 0 |
| External Obsol | | 0 |
| Trend Factor | | 1 |
| Condition | | |
| Condition % | | |
| Percent Good | | 77 |
| RCNLD | | 692,400 |
| Dep % Ovr | | |
| Dep Ovr Comment | | |
| Misc Imp Ovr | | |
| Misc Imp Ovr Comment | | |
| Cost to Cure Ovr | | |
| Cost to Cure Ovr Comment | | |

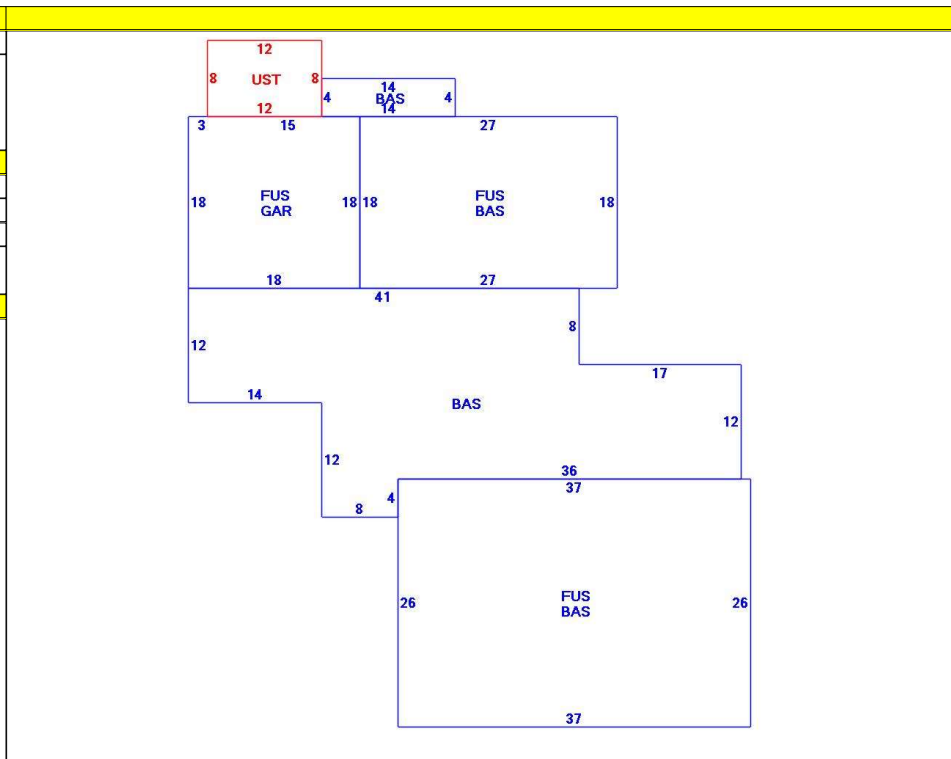

| OB - OUTBUILDING & YARD ITEMS(L) / XF - BUILDING EXTRA FEATURES(B) | | | | | | | | | | |
|--|------------------|-----|-------|------------|--------|----------|------|-------|------------|-------------|
| Code | Description | L/B | Units | Unit Price | Yr Blt | Cond. Cd | % Gd | Grade | Grade Adj. | Appr. Value |
| FPL3 | Fireplace 2 sto | B | 3 | 7000.00 | 1989 | | 77 | | 0.00 | 16,200 |
| GAR | Attached Gara | B | 324 | 40.00 | 1989 | | 77 | | 0.00 | 10,800 |
| UST | Utility Storage- | B | 96 | 17.11 | 1989 | | 77 | | 0.00 | 1,000 |
| FPL2 | Fireplace 1.5 s | B | 1 | 6000.00 | 1989 | | 77 | | 0.00 | 4,600 |
| FPO | Ext FP Openin | B | 3 | 2000.00 | 1989 | | 77 | | 0.00 | 4,600 |
| SHD3 | Shed-High Qu | L | 352 | 25.00 | 1999 | | 80 | | 0.00 | 7,000 |

| BUILDING SUB-AREA SUMMARY SECTION | | | | | | |
|-----------------------------------|-------------------|-------------|------------|----------|-----------|----------------|
| Code | Description | Living Area | Floor Area | Eff Area | Unit Cost | Undeprec Value |
| BAS | First Floor | 2,448 | 2,448 | 2,448 | 213.09 | 521,649 |
| FUS | Upper Story | 1,772 | 1,772 | 1,772 | 213.09 | 377,599 |
| GAR | Attached Garage | 0 | 324 | 0 | 0.00 | 0 |
| UST | Utility Enclosure | 0 | 96 | 0 | 0.00 | 0 |
| Ttl Gross Liv / Lease Area | | 4,220 | 4,640 | 4,220 | | 899,248 |

