

CONSTRUCTION DETAIL			CONSTRUCTION DETAIL (CONTINUED)		
Element	Cd	Description	Element	Cd	Description
Style	04	Cape Cod			
Model	01	Residential			
Grade:	B+	Custom Plus			
Stories	1.5	1 1/2 Stories			
Exterior Wall 1	14	Wood Shingle			
Exterior Wall 2					
RooF Structure	03	Gable/Hip			
RooF Cover	10	Wood Shingle			
Interior Wall 1	03	Plastered			
Interior Wall 2					
Interior Floor 1	14	Carpet			
Interior Floor 2	12	Hardwood			
Heat Fuel	03	Gas			
Heat Type	05	Hot Water			
AC Type	01	None			
Bedrooms	06	6 Bedrooms			
Full Baths	4				
Half Baths	0				
Extra Fixtures					
Total Rooms	10	10 Rooms			
Bath Style					
Kitchen Style					
Occupancy					
UsrflD 105					
Accessory Apt					
Foundation Alt	09	Blk/Pour Ftgs			
Rms Prts					
Bath Split	40	4 Full-0 Half			
			CONDO DATA		
			Parcel Id	C	Owne 0.0
			Adjust Type Code Description Factor%		
			Condo Flr Condo Unit		
			COST / MARKET VALUATION		
			Building Value New	1,211,025	
			Year Built	1900	
			Effective Year Built	1984	
			Depreciation Code	G	
			Remodel Rating		
			Year Remodeled		
			Depreciation %	27	
			Functional Obsol	0	
			External Obsol	0	
			Trend Factor	1	
			Condition		
			Condition %		
			Percent Good	73	
			RCNLD	884,000	
			Dep % Ovr		
			Dep Ovr Comment		
			Misc Imp Ovr		
			Misc Imp Ovr Comment		
			Cost to Cure Ovr		
			Cost to Cure Ovr Comment		

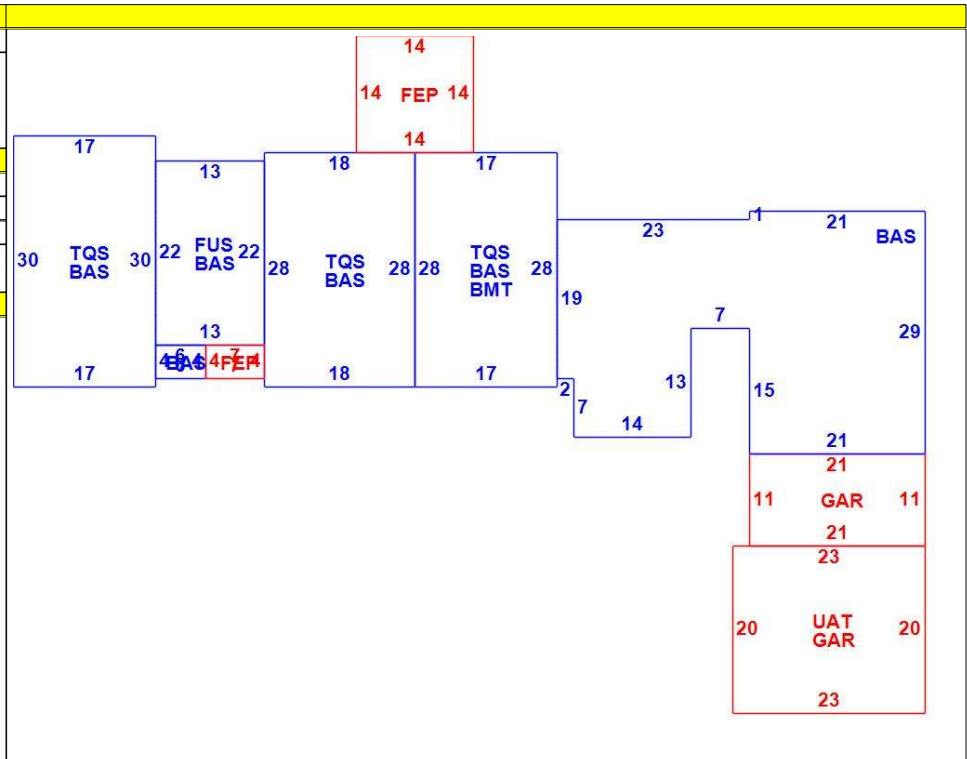

OB - OUTBUILDING & YARD ITEMS(L) / XF - BUILDING EXTRA FEATURES(B)										
Code	Description	L/B	Units	Unit Price	Yr Blt	Cond. Cd	% Gd	Grade	Grade Adj.	Appr. Value
FPL2	Fireplace 1.5 s	B	2	6000.00	1984		73		0.00	8,800
FPO	Ext FP Openin	B	1	2000.00	1984		73		0.00	1,500
SHED	Shed	L	288	18.00	1990		42		0.00	2,200
FEP	Enclosed porc	B	224	70.00	1984		73		0.00	9,900
GAR	Attached Gara	B	691	40.00	1984		73		0.00	17,000
BMT	Basement-Unfi	B	476	26.01	1984		73		0.00	11,900

BUILDING SUB-AREA SUMMARY SECTION						
Code	Description	Living Area	Floor Area	Eff Area	Unit Cost	Undeprec Value
BAS	First Floor	2,902	2,902	2,902	288.13	836,163
BMT	Basement Area	0	476	0	0.00	0
FEP	Enclosed Porch	0	224	0	0.00	0
FUS	Upper Story	286	286	286	288.13	82,406
GAR	Attached Garage	0	691	0	0.00	0
TQS	Three Quarter Story	969	1,490	969	187.38	279,201
UAT	Attic, Unfinished	0	460	46	28.81	13,254
Ttl Gross Liv / Lease Area		4,157	6,529	4,203		1,211,024

