

CURRENT OWNER			TOPO	UTILITIES	STRT / ROAD	LOCATION	CURRENT ASSESSMENT					
MCCARTHY, THOMAS J & NANCY J 1580 W LINCOLN STREET							Description	Code	Assessed	Assessed	801 FY2024 BARNSTABLE, MA	
							RESIDENTL	1010	492,800	492,800		
BIRMINGHAM MI 48009			SUPPLEMENTAL DATA				RES LAND	1010	1,059,100	1,059,100	VISION	
			Alt Prcl ID	Split Zonin	BID Parcel	ResExpt Q	#DL 1 UNNUM LOT	#DL 2	GIS ID F_982318_2694499	Plan Ref. 85/35		Land Ct#
							Total		1,551,900	1,551,900		

RECORD OF OWNERSHIP			BK-VOL/PAGE	SALE DATE	Q/U	V/I	SALE PRIC	VC	PREVIOUS ASSESSMENTS (HISTORY)									
MCCARTHY, THOMAS J & NANCY J			31606	0195	10-19-2018	U	I	710,000	1	Year	Code	Assessed	Year	Code	Assessed			
SCOTTI, LYNN D			31606	0191	10-19-2018	U	I	1	1F	2023	1010	416,200	2022	1010	349,100			
SCOTTI, LYNN TR			29093	0032	08-24-2015	U	I	0	1A		1010	947,500		1010	498,100			
SCOTTI, MICHAEL R & LYNN TRS			12586	0201	10-05-1999	U	I	0	1F					1010	41,200			
SCOTTI, ROSE M TR			3444	0115	03-15-1982	U		0		Total		1,363,700	Total		847,200	Total		828,100

EXEMPTIONS			OTHER ASSESSMENTS					
Year	Code	Description	Amount	Code	Description	Number	Amount	Comm Int
Total			0.00					

ASSESSING NEIGHBORHOOD			NOTES			
Nbhd	Nbhd Name	B	Tracing	Batch		
0114				HYAN		

BUILDING PERMIT RECORD									VISIT / CHANGE HISTORY					
Permit Id	Issue Date	Type	Description	Amount	Insp Date	% Comp	Date Comp	Comments	Date	Id	Type	Is	Cd	Purpost/Result
19-328	02-12-2019	804	Addn Alt-Res	20,371	06-04-2019	100	06-30-2019	KITCHEN REMODEL. DEMO	03-23-2023	CK	22		22	Change of Address
200704318	07-13-2007	NR	New Roof	5,000	06-30-2008	100	06-30-2008	REROOF, STRP OLD SHINGL	06-01-2021	BM	22		22	Change of Address
20065474	12-28-2006	NR	New Roof	5,000	06-30-2007	100	06-30-2007	REROOF, RESIDE, STRP OL	05-22-2020	WD			FR	Field Review
22859	05-05-1997	AD	Addition	3,500	12-31-1997	100	12-31-1997	RESHINGLE, ADD DORMER	09-26-2019	CK	03		16	In Office Review
									09-17-2019	SR	01		02	Bldg Permit Completed
									06-09-2016	JR	03		16	In Office Review
									08-24-2015	AL	03		16	In Office Review

LAND LINE VALUATION SECTION																	
B	Use Code	Description	Zone	LA	Land Units	Unit Price	Size Adj	AC Disc	Site Index	Cond.	Nbhd.	Nbhd. Adj	Notes	Location Adjustmen	Adj Unit P	Land Value	
1	1010	Single Fam M-0	RF-1	4	0.660	AC	176,344.00	1.44436	1.0000	5	1.00	0113	6.300		1.0000	1,604,642	1,059,100
Total Card Land Units					0.66	AC	Parcel Total Land Area					0.66	Total Land Value			1,059,100	

CONSTRUCTION DETAIL			CONSTRUCTION DETAIL (CONTINUED)		
Element	Cd	Description	Element	Cd	Description
Style	63	Gambrel			
Model	01	Residential			
Grade:	C+	Average Plus			
Stories	2.15	2 Stories w/FA			
Exterior Wall 1	14	Wood Shingle			
Exterior Wall 2	16	Stucco on Wood			
Roof Structure	07	Gambrel			
Roof Cover	03	Asph/F Gls/Cmp			
Interior Wall 1	03	Plastered			
Interior Wall 2					
Interior Floor 1	12	Hardwood			
Interior Floor 2					
Heat Fuel	02	Oil			
Heat Type	04	Hot Air			
AC Type	01	None			
Bedrooms	03	3 Bedrooms			
Full Baths	2				
Half Baths	1				
Extra Fixtures					
Total Rooms	7				
Bath Style					
Kitchen Style					
Occupancy					
Usrflid 105					
Accessory Apt					
Foundation Alt	09	Blk/Pour Ftgs			
Rms Prts					
Bath Split	21	2 Full-1 Half			
			CONDO DATA		
			Parcel Id	C	Owne 0.0
				B	S
			Adjust Type	Code	Description
			Condo Flr		Factor%
			Condo Unit		
			COST / MARKET VALUATION		
			Building Value New		513,097
			Year Built		1930
			Effective Year Built		1999
			Depreciation Code		E
			Remodel Rating		
			Year Remodeled		
			Depreciation %		16
			Functional Obsol		0
			External Obsol		0
			Trend Factor		1
			Condition		
			Condition %		
			Percent Good		84
			RCNLD		431,000
			Dep % Ovr		
			Dep Ovr Comment		
			Misc Imp Ovr		
			Misc Imp Ovr Comment		
			Cost to Cure Ovr		
			Cost to Cure Ovr Comment		

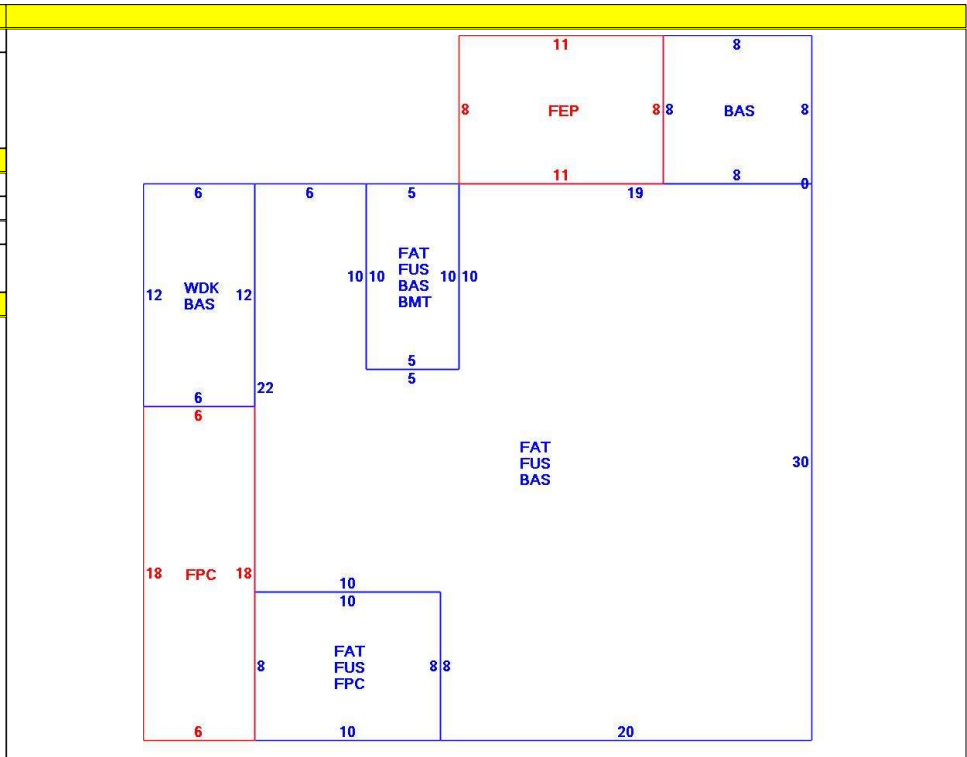

OB - OUTBUILDING & YARD ITEMS(L) / XF - BUILDING EXTRA FEATURES(B)										
Code	Description	L/B	Units	Unit Price	Yr Blt	Cond. Cd	% Gd	Grade	Grade Adj.	Appr. Value
FPL3	Fireplace 2 sto	B	1	7000.00	1999		84		0.00	5,900
GAR2	Det Gar-w/FH	L	720	85.00	1983		64	00	1.00	39,200
WDC	Wood Decking	L	72	20.00	1986		34		0.00	1,100
FOPC	Open Prch-roo	B	188	55.00	1999		84		0.00	6,200
FOPG	Open Prch-rf-c	L	16	49.37	1987		68	C	1.00	900
FEP	Enclosed porc	B	88	70.00	1999		84		0.00	6,500
BMT	Basement-Unfi	B	50	26.01	1999		84		0.00	2,000

BUILDING SUB-AREA SUMMARY SECTION						
Code	Description	Living Area	Floor Area	Eff Area	Unit Cost	Undeprec Value
BAS	First Floor	956	956	956	257.71	246,369
BMT	Basement Area	0	50	0	0.00	0
FAT	Attic, Finished	135	900	135	38.66	34,791
FEP	Enclosed Porch	0	88	0	0.00	0
FPC	Open Porch Conc. Floor	0	188	0	0.00	0
FUS	Upper Story	900	900	900	257.71	231,937
WDK	Wood Deck	0	72	0	0.00	0
Ttl Gross Liv / Lease Area		1,991	3,154	1,991		513,097

