

CURRENT OWNER				TOPO	UTILITIES	STRT / ROAD	LOCATION	CURRENT ASSESSMENT				
KELLY, MARGARET E 55 HIGH VIEW CIRCLE MARSTONS MIL MA 02648				1 Level	6 Septic	1 Paved	1 Marginal View	Description	Code	Assessed	Assessed	801 FY2024 BARNSTABLE, MA VISION
					4 Gas			RESIDNTL	1010	347,200	347,200	
					2 Public Water			RES LAND	1010	172,400	172,400	
SUPPLEMENTAL DATA								Total		519,600	519,600	
Alt Prcl ID				Split Zonin		Plan Ref. 222/157						
BID Parcel				ResExpt Q YES:		Land Ct#						
#DL 1 LOT 74				#DL 2		Life Estate MARGARET E KE						
GIS ID F_944694_2706914				Assoc Pid#								

RECORD OF OWNERSHIP				BK-VOL/PAGE	SALE DATE	Q/U	V/I	SALE PRIC	VC	PREVIOUS ASSESSMENTS (HISTORY)						
KELLY, MARGARET E				30148	0279	12-09-2016	U	I	10	1F	Year	Code	Assessed	Year	Code	Assessed
KELLY, MARGARET E				5636	0021	03-15-1987	Q	I	175,000	U	2023	1010	347,200	2022	1010	296,400
JOAKIM CONSTRUCTION INC				4877	0262	01-15-1986	U	V	90,000	N		1010	156,700		1010	116,100
MORGAN, ROGER P				1843	0013	04-19-1973	U		0						1010	8,500
Total											503,900	Total	412,500	Total	376,300	

EXEMPTIONS				OTHER ASSESSMENTS				
Year	Code	Description	Amount	Code	Description	Number	Amount	Comm Int
2024	5C	RESIDENTIAL EXEMPTION	0.00					
Total			0.00					

ASSESSING NEIGHBORHOOD			
Nbhd	Nbhd Name	B	Tracing
0105			MARSTM

NOTES			
This signature acknowledges a visit by a Data Collector or Assessor			

APPRAISED VALUE SUMMARY			
Appraised Bldg. Value (Card)	309,600		
Appraised Xf (B) Value (Bldg)	29,100		
Appraised Ob (B) Value (Bldg)	8,500		
Appraised Land Value (Bldg)	172,400		
Special Land Value	0		
Total Appraised Parcel Value	519,600		
Valuation Method	C		
Total Appraised Parcel Value	519,600		

BUILDING PERMIT RECORD									VISIT / CHANGE HISTORY					
Permit Id	Issue Date	Type	Description	Amount	Insp Date	% Comp	Date Comp	Comments	Date	Id	Type	Is	Cd	Purpost/Result
EXPR-21-1 B29233	11-30-2021 04-01-1986	835 DW	Sid/Wind/Roof/ Dwelling	12,000 75,000	06-30-2022 01-15-1987	100 100	06-30-2022 06-30-1987	remove and install full-adhere MM 2 STOR	07-28-2023 12-02-2022 05-20-2020 04-10-2018 12-16-2014 10-02-2014 05-17-2005	EG SR LS MS SR SR PT	03 02 03 02 02 01		16 03 FR 16 03 03 00	In Office Review Cycl Insp Comp Field Review In Office Review Cycl Insp Comp Cycl Insp Comp Meas/Listed-Interior Acces

LAND LINE VALUATION SECTION																	
B	Use Code	Description	Zone	LA	Land Units	Unit Price	Size Adj	AC Disc	Site Index	Cond.	Nbhd.	Nbhd. Adj	Notes	Location Adjustmen	Adj Unit P	Land Value	
1	1010	Single Fam M-0	RF	3	0.760 AC	176,344.00	1.28647	1.0000	5	1.00	0105	1.000		1.0000	226,866.5	172,400	
Total Card Land Units					0.76 AC	Parcel Total Land Area					0.76	Total Land Value					172,400

CONSTRUCTION DETAIL			CONSTRUCTION DETAIL (CONTINUED)		
Element	Cd	Description	Element	Cd	Description
Style	05	Saltbox			
Model	01	Residential			
Grade:	C	Average			
Stories	2	2 Stories			
Exterior Wall 1	14	Wood Shingle			
Exterior Wall 2	11	Clapboard			
RooF Structure	03	Gable/Hip			
RooF Cover	03	Asph/F Gls/Cmp			
Interior Wall 1	05	Drywall			
Interior Wall 2					
Interior Floor 1	12	Hardwood			
Interior Floor 2	14	Carpet			
Heat Fuel	03	Gas			
Heat Type	05	Hot Water			
AC Type	03	Central			
Bedrooms	03	3 Bedrooms			
Full Baths	2				
Half Baths	1				
Extra Fixtures					
Total Rooms	6	6 Rooms			
Bath Style					
Kitchen Style					
Occupancy					
Usrflid 105					
Accessory Apt					
Foundation Alt	01	Poured Conc.			
Rms Prts					
Bath Split	21	2 Full-1 Half			
CONDO DATA					
Parcel Id		C	Ownr	0.0	
			B	S	
Adjust Type	Code	Description	Factor%		
Condo Flr					
Condo Unit					
COST / MARKET VALUATION					
Building Value New		368,531			
Year Built		1986			
Effective Year Built		1999			
Depreciation Code		A			
Remodel Rating					
Year Remodeled					
Depreciation %		16			
Functional Obsol		0			
External Obsol		0			
Trend Factor		1			
Condition					
Condition %					
Percent Good		84			
RCNLD		309,600			
Dep % Ovr					
Dep Ovr Comment					
Misc Imp Ovr					
Misc Imp Ovr Comment					
Cost to Cure Ovr					
Cost to Cure Ovr Comment					

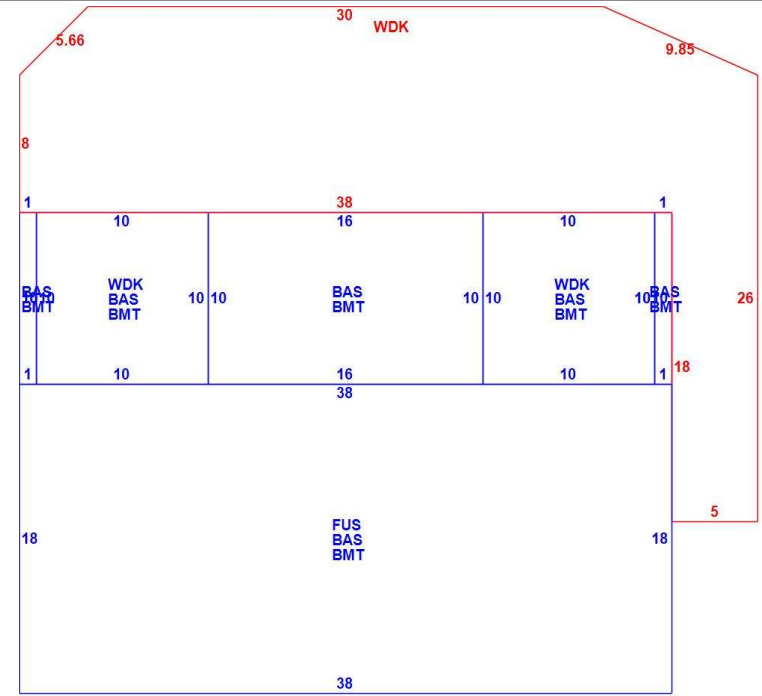

OB - OUTBUILDING & YARD ITEMS(L) / XF - BUILDING EXTRA FEATURES(B)										
Code	Description	L/B	Units	Unit Price	Yr Blt	Cond. Cd	% Gd	Grade	Grade Adj.	Appr. Value
FPL3	Fireplace 2 sto	B	1	7000.00	2001		84		0.00	5,900
WDC	Wood Decking	L	780	20.00	1999		60		0.00	8,500
BMT	Basement-Unfi	B	1,064	26.01	2001		84		0.00	23,200

BUILDING SUB-AREA SUMMARY SECTION							
Code	Description	Living Area	Floor Area	Eff Area	Unit Cost	Undeprec Value	
BAS	First Floor	1,064	1,064	1,064	210.83	224,323	
BMT	Basement Area	0	1,064	0	0.00	0	
FUS	Upper Story	684	684	684	210.83	144,208	
WDK	Wood Deck	0	780	0	0.00	0	
Ttl Gross Liv / Lease Area		1,748	3,592	1,748		368,531	