

CONSTRUCTION DETAIL			CONSTRUCTION DETAIL (CONTINUED)		
Element	Cd	Description	Element	Cd	Description
Style	01	Ranch			
Model	01	Residential			
Grade:	C	Average			
Stories	1	1 Story			
Exterior Wall 1	14	Wood Shingle			
Exterior Wall 2	25	Vinyl Siding			
RooF Structure	03	Gable/Hip			
RooF Cover	03	Asph/F Gls/Cmp			
Interior Wall 1	05	Drywall			
Interior Wall 2					
Interior Floor 1	14	Carpet			
Interior Floor 2					
Heat Fuel	03	Gas			
Heat Type	05	Hot Water			
AC Type	01	None			
Bedrooms	02	2 Bedrooms			
Full Baths	2				
Half Baths	0				
Extra Fixtures					
Total Rooms	6	6 Rooms			
Bath Style					
Kitchen Style					
Occupancy					
Usrflid 105					
Accessory Apt					
Foundation Alt	01	Poured Conc.			
Rms Prts					
Bath Split	20	2 Full-0 Half			

CONDO DATA			
Parcel Id		C	Owne 0.0
Adjust Type	Code	Description	Factor%
Condo Flr			
Condo Unit			

COST / MARKET VALUATION	
Building Value New	361,701
Year Built	1971
Effective Year Built	1996
Depreciation Code	G
Remodel Rating	
Year Remodeled	
Depreciation %	18
Functional Obsol	0
External Obsol	0
Trend Factor	1
Condition	
Condition %	
Percent Good	82
RCNLD	296,600
Dep % Ovr	
Dep Ovr Comment	
Misc Imp Ovr	
Misc Imp Ovr Comment	
Cost to Cure Ovr	
Cost to Cure Ovr Comment	

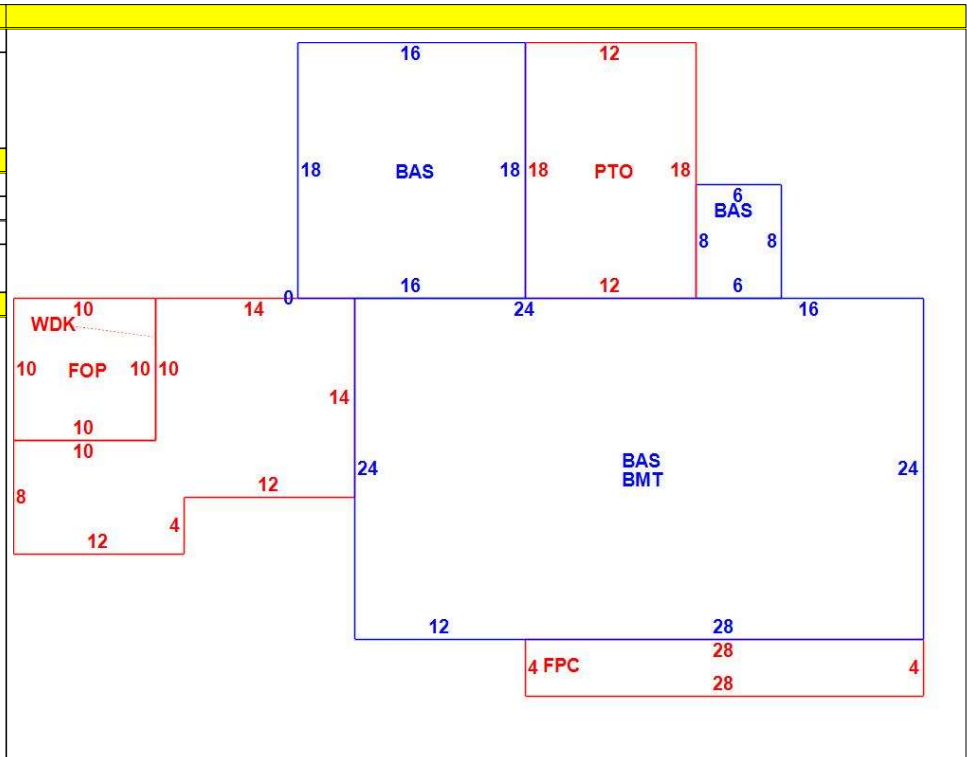

OB - OUTBUILDING & YARD ITEMS(L) / XF - BUILDING EXTRA FEATURES(B)										
Code	Description	L/B	Units	Unit Price	Yr Blt	Cond. Cd	% Gd	Grade	Grade Adj.	Appr. Value
FPL1	Fireplace 1 sto	B	1	5000.00	1998		82		0.00	4,100
WDC	Wood Decking	L	284	20.00	2000		62		0.00	3,600
PAT1	Patio- Average	L	216	5.89	2000		81		0.00	1,100
FOP	Open Porch-ro	B	100	55.00	1998		82		0.00	4,500
BMT	Basement-Unfi	B	960	26.01	1998		82		0.00	21,200
FOPC	Open Prch-roo	B	112	55.00	1998		82		0.00	4,100

BUILDING SUB-AREA SUMMARY SECTION						
Code	Description	Living Area	Floor Area	Eff Area	Unit Cost	Undeprec Value
BAS	First Floor	1,296	1,296	1,296	279.09	361,701
BMT	Basement Area	0	960	0	0.00	0
FOP	Open Porch	0	100	0	0.00	0
FPC	Open Porch Conc. Floor	0	0	0	0.00	0
PTO	Patio	0	216	0	0.00	0
WDK	Wood Deck	0	284	0	0.00	0
Ttl Gross Liv / Lease Area		1,296	2,968	1,296		361,701

