

CURRENT OWNER		TOPO	UTILITIES	STRT / ROAD	LOCATION	CURRENT ASSESSMENT				801 FY2024 BARNSTABLE, MA	
FLEMING, PENNY J  18 MONTE VISTA AVE  NEWINGTON CT 06111		1 Level	2 Public Water	1 Paved		Description	Code	Assessed	Assessed		
			4 Gas			RESIDNTL	1010	366,400	366,400		
			6 Septic			RES LAND	1010	146,700	146,700		
<b>SUPPLEMENTAL DATA</b>						Total				513,100	513,100
Alt Prcl ID Split Zonin BID Parcel ResExpt Q #DL 1 LOT 54 #DL 2 GIS ID F_980822_2696638				Plan Ref. 250/143 Land Ct# #SR Life Estate PP STATU Assoc Pid#							

**VISION**

RECORD OF OWNERSHIP		BK-VOL/PAGE	SALE DATE	Q/U	V/I	SALE PRIC	VC	PREVIOUS ASSESSMENTS (HISTORY)								
FLEMING, PENNY J		33600 0218	03-05-2020	U	I	0	1F	Year	Code	Assessed	Year	Code	Assessed	Year	Code	Assessed
FLEMING, JAMES C & PENNY J		10149 0263	04-15-1996	Q	I	96,000	U	2023	1010	317,300	2022	1010	272,100	2021	1010	214,500
VIOLA, ALFRED & JOY D		2842 0034	12-18-1978	U		0			1010	133,300		1010	98,800		1010	98,800
								Total		450,600	Total		370,900	Total		320,000

EXEMPTIONS			OTHER ASSESSMENTS					This signature acknowledges a visit by a Data Collector or Assessor					
Year	Code	Description	Amount	Code	Description	Number	Amount	Comm Int					
Total			0.00										

ASSESSING NEIGHBORHOOD					APPRAISED VALUE SUMMARY					
Nbhd	Nbhd Name	B	Tracing	Batch						
0105				HYAN	Appraised Bldg. Value (Card)					332,700
					Appraised Xf (B) Value (Bldg)					27,000
					Appraised Ob (B) Value (Bldg)					6,700
					Appraised Land Value (Bldg)					146,700
					Special Land Value					0
					Total Appraised Parcel Value					513,100
					Valuation Method					C
					Total Appraised Parcel Value					513,100

NOTES										VISIT / CHANGE HISTORY					
Permit Id	Issue Date	Type	Description	Amount	Insp Date	% Comp	Date Comp	Comments		Date	Id	Type	Is	Cd	Purpost/Result
										05-22-2020	WD			FR	Field Review
										01-13-2015	SR	02		14	Cyclical Inspection
										01-04-2002	PT	01		00	Meas/Listed-Interior Acces
										11-15-1991	ML	01		00	Meas/Listed-Interior Acces

LAND LINE VALUATION SECTION																
B	Use Code	Description	Zone	LA	Land Units	Unit Price	Size Adj	AC Disc	Site Index	Cond.	Nbhd.	Nbhd. Adj	Notes	Location Adjustmen	Adj Unit P	Land Value
1	1010	Single Fam M-0	RB	4	0.230 AC	176,344.00	3.61599	1.0000	5	1.00	0105	1.000		1.0000	637,659.9	146,700

Total Card Land Units					0.23	AC	Parcel Total Land Area					0.23	Total Land Value					146,700
-----------------------	--	--	--	--	------	----	------------------------	--	--	--	--	------	------------------	--	--	--	--	---------

CONSTRUCTION DETAIL			CONSTRUCTION DETAIL (CONTINUED)		
Element	Cd	Description	Element	Cd	Description
Style	01	Ranch			
Model	01	Residential			
Grade:	C	Average			
Stories	1	1 Story			
Exterior Wall 1	14	Wood Shingle			
Exterior Wall 2	11	Clapboard			
RooF Structure	03	Gable/Hip			
RooF Cover	03	Asph/F Gls/Cmp			
Interior Wall 1	05	Drywall			
Interior Wall 2					
Interior Floor 1	14	Carpet			
Interior Floor 2					
Heat Fuel	03	Gas			
Heat Type	04	Hot Air			
AC Type	03	Central			
Bedrooms	03	3 Bedrooms			
Full Baths	2				
Half Baths	0				
Extra Fixtures					
Total Rooms	6	6 Rooms			
Bath Style					
Kitchen Style					
Occupancy					
Usrflid 105					
Accessory Apt					
Foundation Alt	01	Poured Conc.			
Rms Prts					
Bath Split	20	2 Full-0 Half			

CONDO DATA			
Parcel Id		C	Ownr 0.0
		B	S
Adjust Type	Code	Description	Factor%
Condo Flr			
Condo Unit			

COST / MARKET VALUATION	
Building Value New	421,119
Year Built	1973
Effective Year Built	1992
Depreciation Code	A
Remodel Rating	
Year Remodeled	
Depreciation %	21
Functional Obsol	0
External Obsol	0
Trend Factor	1
Condition	
Condition %	
Percent Good	79
RCNLD	332,700
Dep % Ovr	
Dep Ovr Comment	
Misc Imp Ovr	
Misc Imp Ovr Comment	
Cost to Cure Ovr	
Cost to Cure Ovr Comment	

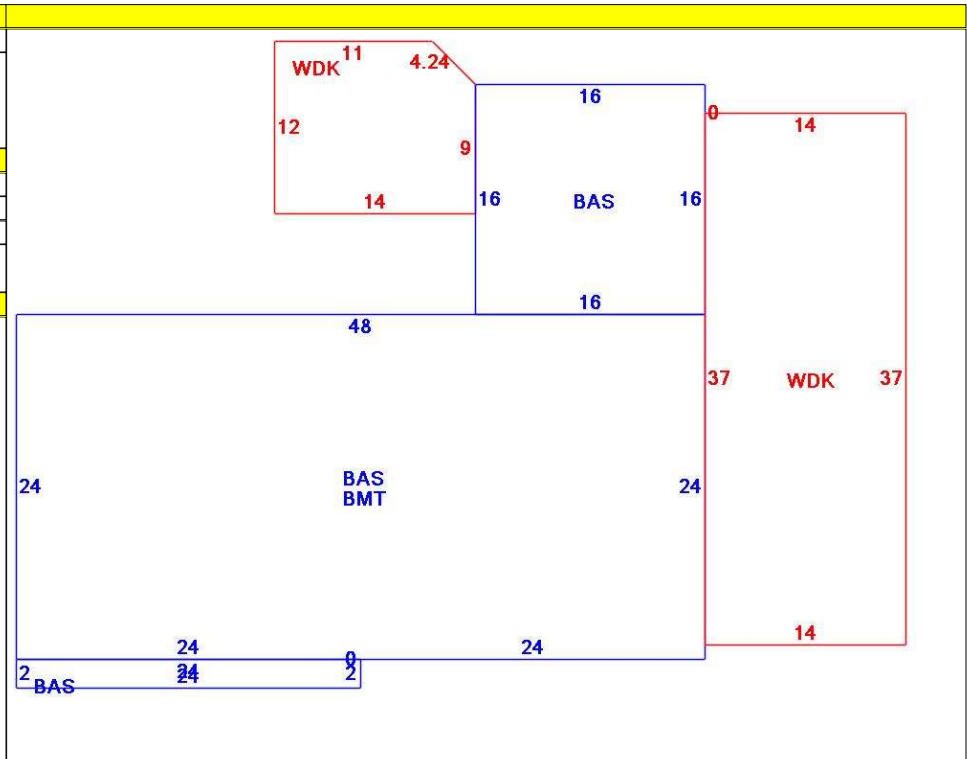

**OB - OUTBUILDING & YARD ITEMS(L) / XF - BUILDING EXTRA FEATURES(B)**

Code	Description	L/B	Units	Unit Price	Yr Blt	Cond. Cd	% Gd	Grade	Grade Adj.	Appr. Value
FPL1	Fireplace 1 sto	B	1	5000.00	1994		79		0.00	4,000
WDC	Wood Decking	L	682	20.00	1996		54		0.00	6,700
BMT	Basement-Unfi	B	1,152	26.01	1994		79		0.00	23,000

**BUILDING SUB-AREA SUMMARY SECTION**

Code	Description	Living Area	Floor Area	Eff Area	Unit Cost	Undeprec Value
BAS	First Floor	1,456	1,456	1,456	289.23	421,119
BMT	Basement Area	0	1,152	0	0.00	0
WDK	Wood Deck	0	682	0	0.00	0
Ttl Gross Liv / Lease Area		1,456	3,290	1,456		421,119

