

| CURRENT OWNER   |  | TOPO           | UTILITIES      | STRT / ROAD      | LOCATION | CURRENT ASSESSMENT |      |          |          | 801<br>FY2024<br>BARNSTABLE, MA<br><br><b>VISION</b> |         |
|---|--|----------------|----------------|------------------|----------|--------------------|------|----------|----------|--|---------|
| MORIN, LINDA C & CONWAY, GLENN<br><br>318 LAKE SHORE DRIVE<br><br>MARSTONS MIL MA 02648 |  | 1 Level        | 6 Septic       | 1 Paved          |          | Description        | Code | Assessed | Assessed |  |         |
|   |  |                | 4 Gas          |                  |          | RESIDNTL           | 1010 | 347,100  | 347,100  |  |         |
|   |  |                | 2 Public Water |                  |          | RES LAND           | 1010 | 155,900  | 155,900  |  |         |
| <b>SUPPLEMENTAL DATA</b>  |  |                |                |                  |          | Total              |      |          |          | 503,000  | 503,000 |
| Alt Prcl ID   |  | Split Zonin    |                | Plan Ref. 249/79 |          |                    |      |          |          |  |         |
| BID Parcel  |  | ResExpt Q YES: |                | Land Ct#         |          |                    |      |          |          |  |         |
| #DL 1 LOT 13  |  | #DL 2          |                | Life Estate      |          |                    |      |          |          |  |         |
| GIS ID F_943360_2707715   |  | Assoc Pid#     |                |                  |          |                    |      |          |          |  |         |

| RECORD OF OWNERSHIP               |       | BK-VOL/PAGE | SALE DATE  | Q/U  | V/I        | SALE PRIC | VC   | PREVIOUS ASSESSMENTS (HISTORY) |      |         |          |      |         |       |      |         |
|-----------------------------------|-------|-------------|------------|------|------------|-----------|------|--------------------------------|------|---------|----------|------|---------|-------|------|---------|
| Year                              | Code  | Assessed    | Year       | Code | Assessed V | Year      | Code | Assessed                       | Year | Code    | Assessed |      |         |       |      |         |
| CONWAY, GLENN ROY ALLEN           | 36027 | 199         | 09-12-2023 | U    | I          | 0         | 1F   |                                |      |         |          |      |         |       |      |         |
| MORIN, LINDA C & CONWAY, GLENN RO | 18917 | 0118        | 08-09-2004 | U    | I          | 100       | 1A   | 2023                           | 1010 | 312,100 | 2022     | 1010 | 262,400 | 2021  | 1010 | 224,400 |
| MORIN, LINDA C                    | 16344 | 0316        | 02-04-2003 | U    | I          | 1         | 1A   |                                | 1010 | 141,700 |          | 1010 | 105,000 |       | 1010 | 105,000 |
| CONWAY, LINDA                     | 6994  | 0177        | 12-18-1989 | U    |            | 0         |      |                                |      |         |          |      |         |       | 1010 | 2,500   |
| CONWAY, LINDA C                   | 6566  | 0323        | 12-18-1989 | U    | I          | 1         | 1A   | Total                          |      | 453,800 | Total    |      | 367,400 | Total |      | 331,900 |

| EXEMPTIONS |      |                       |        | OTHER ASSESSMENTS |             |        |        | This signature acknowledges a visit by a Data Collector or Assessor |  |  |  |  |  |  |  |  |  |  |  |  |
|------------|------|-----------------------|--------|-------------------|-------------|--------|--------|---|--|--|--|--|--|--|--|--|--|--|--|--|
| Year       | Code | Description           | Amount | Code              | Description | Number | Amount | Comm Int  |  |  |  |  |  |  |  |  |  |  |  |  |
| 2024       | 5C   | RESIDENTIAL EXEMPTION | 0.00   |                   |             |        |        |   |  |  |  |  |  |  |  |  |  |  |  |  |
| Total      |      |                       | 0.00   |                   |             |        |        |   |  |  |  |  |  |  |  |  |  |  |  |  |

| ASSESSING NEIGHBORHOOD |           |   |         | APPRAISED VALUE SUMMARY |                               |  |  |  |  |  |         |
|------------------------|-----------|---|---------|-------------------------|-------------------------------|--|--|--|--|--|---------|
| Nbhd                   | Nbhd Name | B | Tracing | Batch                   |                               |  |  |  |  |  |         |
| 0105                   |           |   | MARSTM  |                         | Appraised Bldg. Value (Card)  |  |  |  |  |  | 308,200 |
|                        |           |   |         |                         | Appraised Xf (B) Value (Bldg) |  |  |  |  |  | 36,400  |
|                        |           |   |         |                         | Appraised Ob (B) Value (Bldg) |  |  |  |  |  | 2,500   |
|                        |           |   |         |                         | Appraised Land Value (Bldg)   |  |  |  |  |  | 155,900 |
|                        |           |   |         |                         | Special Land Value            |  |  |  |  |  | 0       |
|                        |           |   |         |                         | Total Appraised Parcel Value  |  |  |  |  |  | 503,000 |
|                        |           |   |         |                         | Valuation Method              |  |  |  |  |  | C       |
|                        |           |   |         |                         | Total Appraised Parcel Value  |  |  |  |  |  | 503,000 |

| BUILDING PERMIT RECORD |            |      |             |        |            |        |            | VISIT / CHANGE HISTORY |            |    |      |    |    |                   |  |
|------------------------|------------|------|-------------|--------|------------|--------|------------|------------------------|------------|----|------|----|----|-------------------|--|
| Permit Id              | Issue Date | Type | Description | Amount | Insp Date  | % Comp | Date Comp  | Comments               | Date       | Id | Type | Is | Cd | Purpost/Result    |  |
| B15890                 | 02-01-1973 | DW   | Dwelling    | 0      | 06-15-1974 | 100    | 12-31-1974 | MM 11/2 S              | 07-20-2023 | JO | 03   |    | 16 | In Office Review  |  |
|                        |            |      |             |        |            |        |            |                        | 07-20-2023 | AG | 22   |    | 22 | Change of Address |  |
|                        |            |      |             |        |            |        |            |                        | 12-01-2022 | SR | 01   |    | 03 | Cycl Insp Comp    |  |
|                        |            |      |             |        |            |        |            |                        | 05-21-2020 | LS |      |    |    | Field Review      |  |
|                        |            |      |             |        |            |        |            |                        | 09-23-2014 | SR | 01   |    | 03 | Cycl Insp Comp    |  |
|                        |            |      |             |        |            |        |            |                        | 04-03-2014 | JR | 03   |    | 16 | In Office Review  |  |
|                        |            |      |             |        |            |        |            |                        | 03-29-2011 | MA | 22   |    | 22 | Change of Address |  |

| LAND LINE VALUATION SECTION |          |                |      |    |            |            |                        |         |            |       |       |           |                  |                    |            |            |         |
|-----------------------------|----------|----------------|------|----|------------|------------|------------------------|---------|------------|-------|-------|-----------|------------------|--------------------|------------|------------|---------|
| B                           | Use Code | Description    | Zone | LA | Land Units | Unit Price | Size Adj               | AC Disc | Site Index | Cond. | Nbhd. | Nbhd. Adj | Notes            | Location Adjustmen | Adj Unit P | Land Value |         |
| 1                           | 1010     | Single Fam M-0 | RF   | 3  | 0.460      | AC         | 176,344.00             | 1.92125 | 1.0000     | 5     | 1.00  | 0105      | 1.000            |                    | 1.0000     | 338,809.7  | 155,900 |
| Total Card Land Units       |          |                |      |    | 0.46       | AC         | Parcel Total Land Area |         |            |       |       | 0.46      | Total Land Value |                    |            | 155,900    |         |

| CONSTRUCTION DETAIL |      |                | CONSTRUCTION DETAIL (CONTINUED) |    |             |
|---------------------|------|----------------|---------------------------------|----|-------------|
| Element             | Cd   | Description    | Element                         | Cd | Description |
| Style               | 04   | Cape Cod       |                                 |    |             |
| Model               | 01   | Residential    |                                 |    |             |
| Grade:              | C    | Average        |                                 |    |             |
| Stories             | 1.66 |                |                                 |    |             |
| Exterior Wall 1     | 14   | Wood Shingle   |                                 |    |             |
| Exterior Wall 2     | 11   | Clapboard      |                                 |    |             |
| Roof Structure      | 03   | Gable/Hip      |                                 |    |             |
| Roof Cover          | 03   | Asph/F Gls/Cmp |                                 |    |             |
| Interior Wall 1     | 05   | Drywall        |                                 |    |             |
| Interior Wall 2     |      |                |                                 |    |             |
| Interior Floor 1    | 14   | Carpet         |                                 |    |             |
| Interior Floor 2    |      |                |                                 |    |             |
| Heat Fuel           | 03   | Gas            |                                 |    |             |
| Heat Type           | 05   | Hot Water      |                                 |    |             |
| AC Type             | 01   | None           |                                 |    |             |
| Bedrooms            | 04   | 4 Bedrooms     |                                 |    |             |
| Full Baths          | 1    |                |                                 |    |             |
| Half Baths          | 1    |                |                                 |    |             |
| Extra Fixtures      |      |                |                                 |    |             |
| Total Rooms         | 8    | 8 Rooms        |                                 |    |             |
| Bath Style          |      |                |                                 |    |             |
| Kitchen Style       |      |                |                                 |    |             |
| Occupancy           |      |                |                                 |    |             |
| Usrflid 105         |      |                |                                 |    |             |
| Accessory Apt       |      |                |                                 |    |             |
| Foundation Alt      | 01   | Poured Conc.   |                                 |    |             |
| Rms Prts            |      |                |                                 |    |             |
| Bath Split          | 11   | 1 Full-1 Half  |                                 |    |             |

| CONDO DATA  |      |             |          |
|-------------|------|-------------|----------|
| Parcel Id   |      | C           | Owne 0.0 |
|             |      | B           | S        |
| Adjust Type | Code | Description | Factor%  |
| Condo Flr   |      |             |          |
| Condo Unit  |      |             |          |

| COST / MARKET VALUATION  |         |
|--------------------------|---------|
| Building Value New       | 390,122 |
| Year Built               | 1973    |
| Effective Year Built     | 1992    |
| Depreciation Code        | A       |
| Remodel Rating           |         |
| Year Remodeled           |         |
| Depreciation %           | 21      |
| Functional Obsol         | 0       |
| External Obsol           | 0       |
| Trend Factor             | 1       |
| Condition                |         |
| Condition %              |         |
| Percent Good             | 79      |
| RCNLD                    | 308,200 |
| Dep % Ovr                |         |
| Dep Ovr Comment          |         |
| Misc Imp Ovr             |         |
| Misc Imp Ovr Comment     |         |
| Cost to Cure Ovr         |         |
| Cost to Cure Ovr Comment |         |

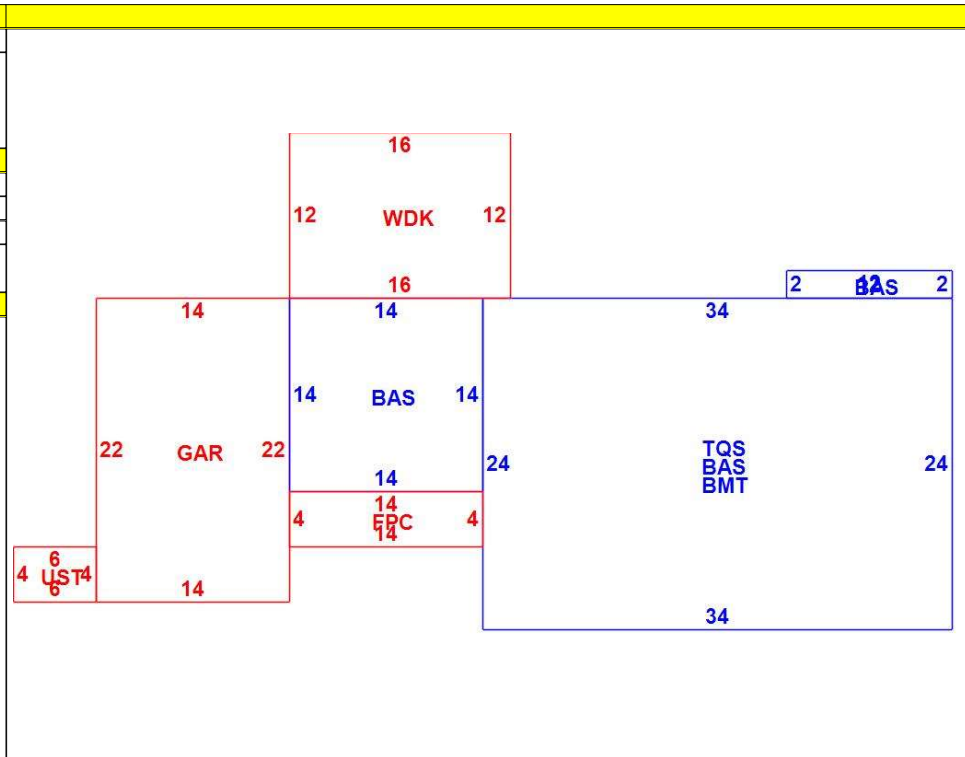

| OB - OUTBUILDING & YARD ITEMS(L) / XF - BUILDING EXTRA FEATURES(B) |                  |     |       |            |        |          |      |       |            |             |
|--|------------------|-----|-------|------------|--------|----------|------|-------|------------|-------------|
| Code   | Description      | L/B | Units | Unit Price | Yr Blt | Cond. Cd | % Gd | Grade | Grade Adj. | Appr. Value |
| FPL2   | Fireplace 1.5 s  | B   | 1     | 6000.00    | 1994   |          | 79   |       | 0.00       | 4,700       |
| WDC  | Wood Decking     | L   | 192   | 20.00      | 1996   |          | 54   |       | 0.00       | 2,500       |
| FOPC   | Open Prch-roo    | B   | 56    | 55.00      | 1994   |          | 79   |       | 0.00       | 2,400       |
| GAR  | Attached Gara    | B   | 308   | 40.00      | 1994   |          | 79   |       | 0.00       | 10,700      |
| UST  | Utility Storage- | B   | 24    | 17.11      | 1994   |          | 79   |       | 0.00       | 400         |
| BMT  | Basement-Unfi    | B   | 816   | 26.01      | 1994   |          | 79   |       | 0.00       | 18,200      |

| BUILDING SUB-AREA SUMMARY SECTION |                        |             |            |          |           |                |  |
|-----------------------------------|------------------------|-------------|------------|----------|-----------|----------------|--|
| Code                              | Description            | Living Area | Floor Area | Eff Area | Unit Cost | Undeprec Value |  |
| BAS                               | First Floor            | 1,036       | 1,036      | 1,036    | 249.12    | 258,088        |  |
| BMT                               | Basement Area          | 0           | 816        | 0        | 0.00      | 0              |  |
| FPC                               | Open Porch Conc. Floor | 0           | 56         | 0        | 0.00      | 0              |  |
| GAR                               | Attached Garage        | 0           | 308        | 0        | 0.00      | 0              |  |
| TQS                               | Three Quarter Story    | 530         | 816        | 530      | 161.81    | 132,034        |  |
| UST                               | Utility Enclosure      | 0           | 24         | 0        | 0.00      | 0              |  |
| WDK                               | Wood Deck              | 0           | 192        | 0        | 0.00      | 0              |  |
| Ttl Gross Liv / Lease Area        |                        | 1,566       | 3,248      | 1,566    |           | 390,122        |  |