

CURRENT OWNER		TOPO		UTILITIES		STRT / ROAD		LOCATION		CURRENT ASSESSMENT			
LANE, MAUREEN S  357 LEXINGTON ST  WOBURN MA 01801		1	Level	2	Public Water	1	Paved			Description	Code	Assessed	Assessed
		4	Gas							RESIDNTL	1010	358,800	358,800
		6	Septic							RES LAND	1010	147,800	147,800
<b>SUPPLEMENTAL DATA</b>										Total		506,600	506,600
Alt Prcl ID Split Zonin BID Parcel ResExpt Q #DL 1 LOT 53 #DL 2 GIS ID F_980583_2698278				Plan Ref. 340/92 Land Ct# #SR Life Estate PP STATU Assoc Pid#									

801  
 FY2024  
 BARNSTABLE, MA

**VISION**

RECORD OF OWNERSHIP		BK-VOL/PAGE		SALE DATE		Q/U		V/I		SALE PRIC		VC		PREVIOUS ASSESSMENTS (HISTORY)						
LANE, MAUREEN S		12795	0274	01-24-2000		Q	I			140,000	00	Year	Code	Assessed	Year	Code	Assessed	Year	Code	Assessed
FOLEY, M IRENE		6339	0342	07-15-1988		Q	I			138,000	U	2023	1010	309,600	2022	1010	268,000	2021	1010	218,200
COLETTI, RONALD D		5128	0283	06-15-1986		Q	I			132,000	U		1010	134,400		1010	99,500		1010	99,500
ANTIPOSTI, PAUL D		4724	0037	09-15-1985		Q	V			22,500	U								1010	3,000
ROSA, DOMINICK		3131	0093	07-31-1980		U				0		Total		444,000	Total		367,500	Total		320,700

EXEMPTIONS			OTHER ASSESSMENTS					
Year	Code	Description	Amount	Code	Description	Number	Amount	Comm Int
Total			0.00					

This signature acknowledges a visit by a Data Collector or Assessor

ASSESSING NEIGHBORHOOD				
Nbhd	Nbhd Name	B	Tracing	Batch
0105				HYAN

APPRAISED VALUE SUMMARY	
Appraised Bldg. Value (Card)	309,800
Appraised Xf (B) Value (Bldg)	46,000
Appraised Ob (B) Value (Bldg)	3,000
Appraised Land Value (Bldg)	147,800
Special Land Value	0
Total Appraised Parcel Value	506,600
Valuation Method	C
Total Appraised Parcel Value	506,600

NOTES							

BUILDING PERMIT RECORD								VISIT / CHANGE HISTORY						
Permit Id	Issue Date	Type	Description	Amount	Insp Date	% Comp	Date Comp	Comments	Date	Id	Type	Is	Cd	Purpost/Result
75950	04-12-2004	AD	Addition	18,000	10-22-2004	100	01-01-2005		05-22-2020	WD			FR	Field Review
72504	10-24-2003	AD	Addition		10-22-2004	100	01-01-2005		01-05-2015	SR	02		14	Cyclical Inspection
B28529	10-02-1985	DW	Dwelling	50,000	09-15-1986	100		HY 1 STOR	10-22-2004	MF	02		02	Bldg Permit Completed
B28529A	10-01-1985	DW	Dwelling	50,000		100		HY 1 STOR	06-09-2004	MF	02		02	Bldg Permit Completed
									01-17-2002	PT	01		00	Meas/Listed-Interior Acces
									05-04-2000	JG			03	Cycl Insp Comp
									09-15-1991	ME	02		01	Meas/Est

LAND LINE VALUATION SECTION																		
B	Use Code	Description	Zone	LA	Land Units	Unit Price	Size Adj	AC Disc	Site Index	Cond.	Nbhd.	Nbhd. Adj	Notes	Location Adjustmen	Adj Unit P	Land Value		
1	1010	Single Fam M-0	RB	4	0.240	AC	176,344.00	3.49265	1.0000	5	1.00	0105	1.000		1.0000	615,916.6	147,800	
Total Card Land Units					0.24	AC	Parcel Total Land Area					0.24	Total Land Value					147,800

CONSTRUCTION DETAIL			CONSTRUCTION DETAIL (CONTINUED)		
Element	Cd	Description	Element	Cd	Description
Style	01	Ranch			
Model	01	Residential			
Grade:	C	Average			
Stories	1	1 Story			
Exterior Wall 1	14	Wood Shingle			
Exterior Wall 2	11	Clapboard			
Roof Structure	03	Gable/Hip			
Roof Cover	03	Asph/F Gls/Cmp			
Interior Wall 1	05	Drywall			
Interior Wall 2					
Interior Floor 1	12	Hardwood			
Interior Floor 2					
Heat Fuel	03	Gas			
Heat Type	04	Hot Air			
AC Type	03	Central			
Bedrooms	03	3 Bedrooms			
Full Baths	2				
Half Baths	0				
Extra Fixtures					
Total Rooms	6				
Bath Style					
Kitchen Style					
Occupancy					
Usrflid 105					
Accessory Apt					
Foundation Alt	01	Poured Conc.			
Rms Prts					
Bath Split	20	2 Full-0 Half			

CONDO DATA			
Parcel Id	C	Owne	0.0
Adjust Type	Code	Description	Factor%
Condo Flr	Condo Unit		

COST / MARKET VALUATION	
Building Value New	368,859
Year Built	1985
Effective Year Built	1998
Depreciation Code	A
Remodel Rating	
Year Remodeled	
Depreciation %	16
Functional Obsol	0
External Obsol	0
Trend Factor	1
Condition	
Condition %	
Percent Good	84
RCNLD	309,800
Dep % Ovr	
Dep Ovr Comment	
Misc Imp Ovr	
Misc Imp Ovr Comment	
Cost to Cure Ovr	
Cost to Cure Ovr Comment	

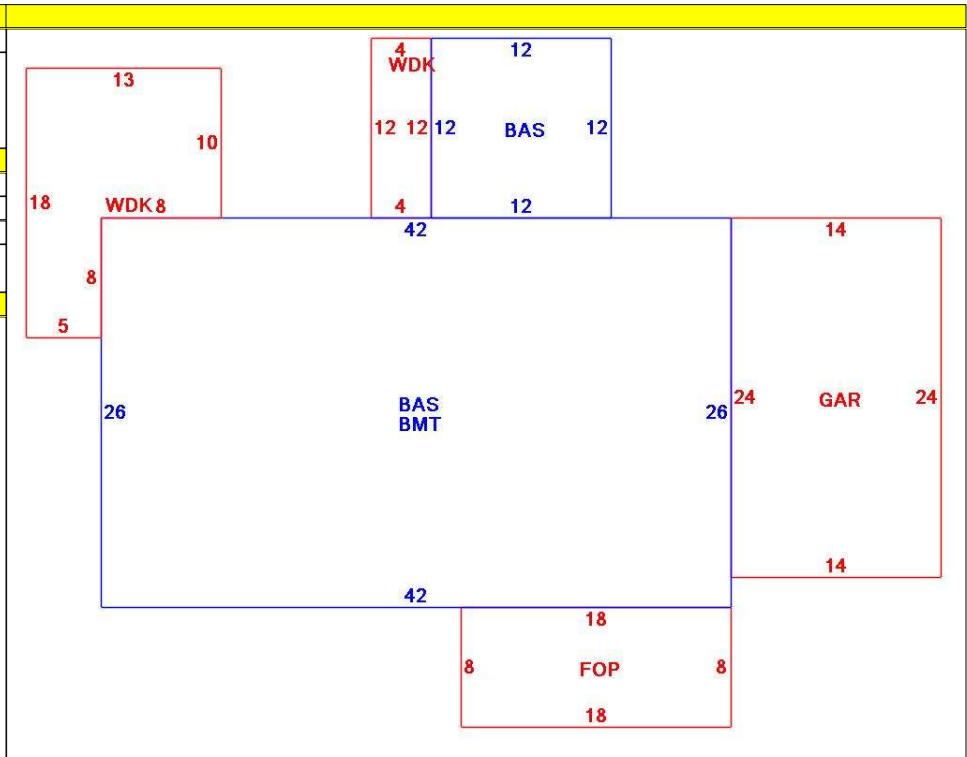

OB - OUTBUILDING & YARD ITEMS(L) / XF - BUILDING EXTRA FEATURES(B)										
Code	Description	L/B	Units	Unit Price	Yr Blt	Cond. Cd	% Gd	Grade	Grade Adj.	Appr. Value
FPL1	Fireplace 1 sto	B	1	5000.00	2000		84		0.00	4,200
WDC	Wood Decking	L	218	20.00	1999		60		0.00	3,000
FOP	Open Porch-ro	B	144	55.00	2000		84		0.00	6,000
GAR	Attached Gara	B	336	40.00	2000		84		0.00	12,100
BMT	Basement-Unfi	B	1,092	26.01	2000		84		0.00	23,700

BUILDING SUB-AREA SUMMARY SECTION						
Code	Description	Living Area	Floor Area	Eff Area	Unit Cost	Undeprec Value
BAS	First Floor	1,236	1,236	1,236	298.43	368,859
BMT	Basement Area	0	1,092	0	0.00	0
FOP	Open Porch	0	144	0	0.00	0
GAR	Attached Garage	0	336	0	0.00	0
WDC	Wood Deck	0	218	0	0.00	0
Ttl Gross Liv / Lease Area		1,236	3,026	1,236		368,859

