

CURRENT OWNER		TOPO	UTILITIES	STRT / ROAD	LOCATION	CURRENT ASSESSMENT				801 FY2024 BARNSTABLE, MA  <b>VISION</b>	
BARBOZA, VALDENIR S & RENATA S  156 FAWCETT LANE  HYANNIS MA 02601	1 Level	6 Septic	1 Paved			Description	Code	Assessed	Assessed		
		4 Gas				RESIDNTL	1010	279,600	279,600		
		2 Public Water				RES LAND	1010	138,800	138,800		
<b>SUPPLEMENTAL DATA</b>						Total				418,400	418,400
Alt Prcl ID		Split Zonin		Plan Ref.							
BID Parcel		ResExpt Q YES:		Land Ct# 22825-P (SH-1)							
#DL 1 LOT 76		#DL 2		Life Estate							
GIS ID F_982069_2700625		Assoc Pid#									

RECORD OF OWNERSHIP		BK-VOL/PAGE	SALE DATE	Q/U	V/I	SALE PRIC	VC	PREVIOUS ASSESSMENTS (HISTORY)									
BARBOZA, VALDENIR S & RENATA S	C169057	0	05-02-2003	Q	I	271,000	00	Year	Code	Assessed	Year	Code	Assessed	Year	Code	Assessed	
PIERCE, SHAUN	C158747	0	08-18-2000	Q	I	146,000	00	2023	1010	243,600	2022	1010	215,900	2021	1010	179,000	
FIRMIN, MICHAEL S & ANITA I	C128587	0	12-15-1992	Q	I	90,000	U		1010	133,200		1010	98,700		1010	93,500	
KEARNS, ROBERT J & DEBORAH	C115112	0	08-15-1988	Q	I	120,000	U										
LANGLOIS, CYNTHIA J	C103767	0	10-15-1985	Q	I	67,500	U										
Total								376,800		Total		314,600		Total		275,300	

EXEMPTIONS				OTHER ASSESSMENTS				This signature acknowledges a visit by a Data Collector or Assessor										
Year	Code	Description	Amount	Code	Description	Number	Amount	Comm Int										
2010	5C	RESIDENTIAL EXEMPTION	0.00															
Total			0.00															

ASSESSING NEIGHBORHOOD				APPRAISED VALUE SUMMARY				
Nbhd	Nbhd Name	B	Tracing	Batch				
0104				HYAN				

NOTES										APPRAISED VALUE SUMMARY							
										Appraised Bldg. Value (Card)							226,300
										Appraised Xf (B) Value (Bldg)							50,500
										Appraised Ob (B) Value (Bldg)							2,800
										Appraised Land Value (Bldg)							138,800
										Special Land Value							0
										Total Appraised Parcel Value							418,400
										Valuation Method							C
										Total Appraised Parcel Value							418,400

BUILDING PERMIT RECORD										VISIT / CHANGE HISTORY						
Permit Id	Issue Date	Type	Description	Amount	Insp Date	% Comp	Date Comp	Comments		Date	Id	Type	Is	Cd	Purpost/Result	
B32907	05-01-1989	SP	Swimming Pool	3,000	01-15-1990	100		HY SW.POO		04-23-2020	WD			FR	Field Review	
										02-12-2019	CL			16	In Office Review	
										02-09-2001	SM	01		00	Meas/Listed-Interior Acces	

LAND LINE VALUATION SECTION																		
B	Use Code	Description	Zone	LA	Land Units	Unit Price	Size Adj	AC Disc	Site Index	Cond.	Nbhd.	Nbhd. Adj	Notes		Location Adjustmen	Adj Unit P	Land Value	
1	1010	Single Fam M-0	RB	4	0.410	AC	176,344.00	2.13291	1.0000	5	1.00	0104	0.900			1.0000	338,509.9	138,800
Total Card Land Units					0.41	AC	Parcel Total Land Area					0.41	Total Land Value				138,800	

CONSTRUCTION DETAIL			CONSTRUCTION DETAIL (CONTINUED)		
Element	Cd	Description	Element	Cd	Description
Style	01	Ranch			
Model	01	Residential			
Grade:	C	Average			
Stories	1	1 Story			
Exterior Wall 1	14	Wood Shingle			
Exterior Wall 2					
RooF Structure	03	Gable/Hip			
RooF Cover	03	Asph/F Gls/Cmp			
Interior Wall 1	05	Drywall			
Interior Wall 2					
Interior Floor 1	12	Hardwood			
Interior Floor 2					
Heat Fuel	03	Gas			
Heat Type	04	Hot Air			
AC Type	01	None			
Bedrooms	02	2 Bedrooms			
Full Baths	1				
Half Baths	0				
Extra Fixtures					
Total Rooms	5	5 Rooms			
Bath Style					
Kitchen Style					
Occupancy					
Usrflid 105					
Accessory Apt					
Foundation Alt	01	Poured Conc.			
Rms Prts					
Bath Split	10	1 Full-0 Half			

CONDO DATA			
Parcel Id		C	Owne 0.0
Adjust Type	Code	Description	Factor%
Condo Flr			
Condo Unit			

COST / MARKET VALUATION	
Building Value New	293,901
Year Built	1968
Effective Year Built	1990
Depreciation Code	A
Remodel Rating	
Year Remodeled	
Depreciation %	23
Functional Obsol	0
External Obsol	0
Trend Factor	1
Condition	
Condition %	
Percent Good	77
RCNLD	226,300
Dep % Ovr	
Dep Ovr Comment	
Misc Imp Ovr	
Misc Imp Ovr Comment	
Cost to Cure Ovr	
Cost to Cure Ovr Comment	

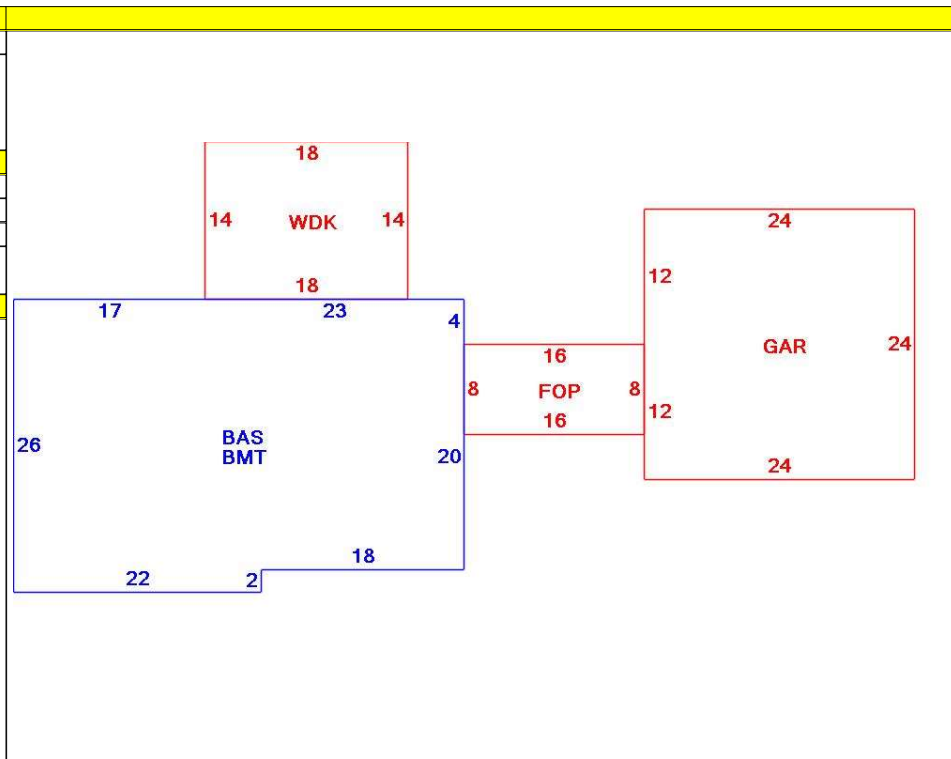

OB - OUTBUILDING & YARD ITEMS(L) / XF - BUILDING EXTRA FEATURES(B)										
Code	Description	L/B	Units	Unit Price	Yr Blt	Cond. Cd	% Gd	Grade	Grade Adj.	Appr. Value
FPL1	Fireplace 1 sto	B	1	5000.00	1992		77		0.00	3,900
BFA	Bsmt Fin-Avg	B	400	17.36	1992		77		0.00	5,300
WDC	Wood Decking	L	252	20.00	1995		52		0.00	2,800
FOP	Open Porch-ro	B	128	55.00	1992		77		0.00	5,100
GAR	Attached Gara	B	576	40.00	1992		77		0.00	15,700
BMT	Basement-Unfi	B	1,004	26.01	1992		77		0.00	20,500

BUILDING SUB-AREA SUMMARY SECTION						
Code	Description	Living Area	Floor Area	Eff Area	Unit Cost	Undeprec Value
BAS	First Floor	1,004	1,004	1,004	292.73	293,901
BMT	Basement Area	0	1,004	0	0.00	0
FOP	Open Porch	0	128	0	0.00	0
GAR	Attached Garage	0	576	0	0.00	0
WDC	Wood Deck	0	252	0	0.00	0
Ttl Gross Liv / Lease Area		1,004	2,964	1,004		293,901

