

CURRENT OWNER		TOPO	UTILITIES	STRT / ROAD	LOCATION	CURRENT ASSESSMENT				801 FY2024 BARNSTABLE, MA  <b>VISION</b>
KNOWLTON, GEOFFREY & DONNELL  48 PONTIAC STREET  HYANNIS MA 02601	1 Level	2 Public Water				Description	Code	Assessed	Assessed	
		4 Gas				RESIDNTL	1010	297,400	297,400	
		6 Septic				RES LAND	1010	134,700	134,700	
<b>SUPPLEMENTAL DATA</b>						Total				432,100
Alt Prcl ID Split Zonin BID Parcel ResExpt Q #DL 1 LOT 4 #DL 2 GIS ID F_981794_2699765				Plan Ref. 236/145 Land Ct# #SR Life Estate PP STATU Assoc Pid#						

RECORD OF OWNERSHIP		BK-VOL/PAGE	SALE DATE	Q/U	V/I	SALE PRIC	VC	PREVIOUS ASSESSMENTS (HISTORY)								
KNOWLTON, GEOFFREY & DONNELLY, KELLEY, PAMELA M HEIRS OF KELLEY, PAMELA M KELLEY, KAREN M	34989	180	03-21-2022	U	I	342,000	1	Year	Code	Assessed	Year	Code	Assessed			
	BA21P11	0	11-20-2020	U	I	0	1F	2023	1010	253,800	2022	1010	219,600			
	5279	0245	09-15-1986	Q	I	75,000	U		1010	129,200		1010	95,700			
	3358	0211	09-11-1981	U		0		Total		383,000	Total		315,300	Total		268,400

EXEMPTIONS			OTHER ASSESSMENTS				This signature acknowledges a visit by a Data Collector or Assessor							
Year	Code	Description	Amount	Code	Description	Number	Amount	Comm Int						
Total			0.00											

ASSESSING NEIGHBORHOOD				APPRAISED VALUE SUMMARY				
Nbhd	Nbhd Name	B	Tracing	Batch				
0104				HYAN				
NOTES				Appraised Bldg. Value (Card)				274,000
				Appraised Xf (B) Value (Bldg)				19,200
				Appraised Ob (B) Value (Bldg)				4,200
				Appraised Land Value (Bldg)				134,700
				Special Land Value				0
				Total Appraised Parcel Value				432,100
				Valuation Method				C
				Total Appraised Parcel Value				432,100

BUILDING PERMIT RECORD									VISIT / CHANGE HISTORY					
Permit Id	Issue Date	Type	Description	Amount	Insp Date	% Comp	Date Comp	Comments	Date	Id	Type	Is	Cd	Purpost/Result
81471	12-28-2004	RE	Remodel	5,120	07-08-2011	100	06-30-2011	HCAP BATH	04-23-2020	WD			FR	Field Review
61625	06-05-2002	AD	Addition	3,000	10-03-2002	100	01-01-2003	REPL GREENHOUSE w BAS	11-27-2017	SR	02		03	Cycl Insp Comp
									07-08-2011	NF	01		00	Meas/Listed-Interior Acces
									10-03-2002	MF	02		02	Bldg Permit Completed
									01-26-2001	PT	01		00	Meas/Listed-Interior Acces
									11-15-1990	ML	01		00	Meas/Listed-Interior Acces

LAND LINE VALUATION SECTION																	
B	Use Code	Description	Zone	LA	Land Units	Unit Price	Size Adj	AC Disc	Site Index	Cond.	Nbhd.	Nbhd. Adj	Notes	Location Adjustmen	Adj Unit P	Land Value	
1	1010	Single Fam M-0	RB	4	0.270	AC	176,344.00	3.14262	1.0000	5	1.00	0104	0.900		1.0000	498,771.3	134,700
Total Card Land Units					0.27	AC	Parcel Total Land Area					0.27	Total Land Value			134,700	

CONSTRUCTION DETAIL			CONSTRUCTION DETAIL (CONTINUED)		
Element	Cd	Description	Element	Cd	Description
Style	01	Ranch			
Model	01	Residential			
Grade:	C	Average			
Stories	1	1 Story			
Exterior Wall 1	14	Wood Shingle			
Exterior Wall 2	11	Clapboard			
Roof Structure	03	Gable/Hip			
Roof Cover	03	Asph/F Gls/Cmp			
Interior Wall 1	05	Drywall			
Interior Wall 2					
Interior Floor 1	09	Pine/Soft Wood			
Interior Floor 2	12	Hardwood			
Heat Fuel	03	Gas			
Heat Type	05	Hot Water			
AC Type	01	None			
Bedrooms	02	2 Bedrooms			
Full Baths	2				
Half Baths	0				
Extra Fixtures					
Total Rooms	5	5 Rooms			
Bath Style					
Kitchen Style					
Occupancy					
Usrflid 105					
Accessory Apt					
Foundation Alt	01	Poured Conc.			
Rms Prts					
Bath Split	20	2 Full-0 Half			

CONDO DATA				
Parcel Id		C	Ownr	0.0
Adjust Type	Code	Description	Factor%	
Condo Flr				
Condo Unit				

COST / MARKET VALUATION	
Building Value New	338,260
Year Built	1978
Effective Year Built	1995
Depreciation Code	A
Remodel Rating	
Year Remodeled	
Depreciation %	19
Functional Obsol	0
External Obsol	0
Trend Factor	1
Condition	
Condition %	
Percent Good	81
RCNLD	274,000
Dep % Ovr	
Dep Ovr Comment	
Misc Imp Ovr	
Misc Imp Ovr Comment	
Cost to Cure Ovr	
Cost to Cure Ovr Comment	

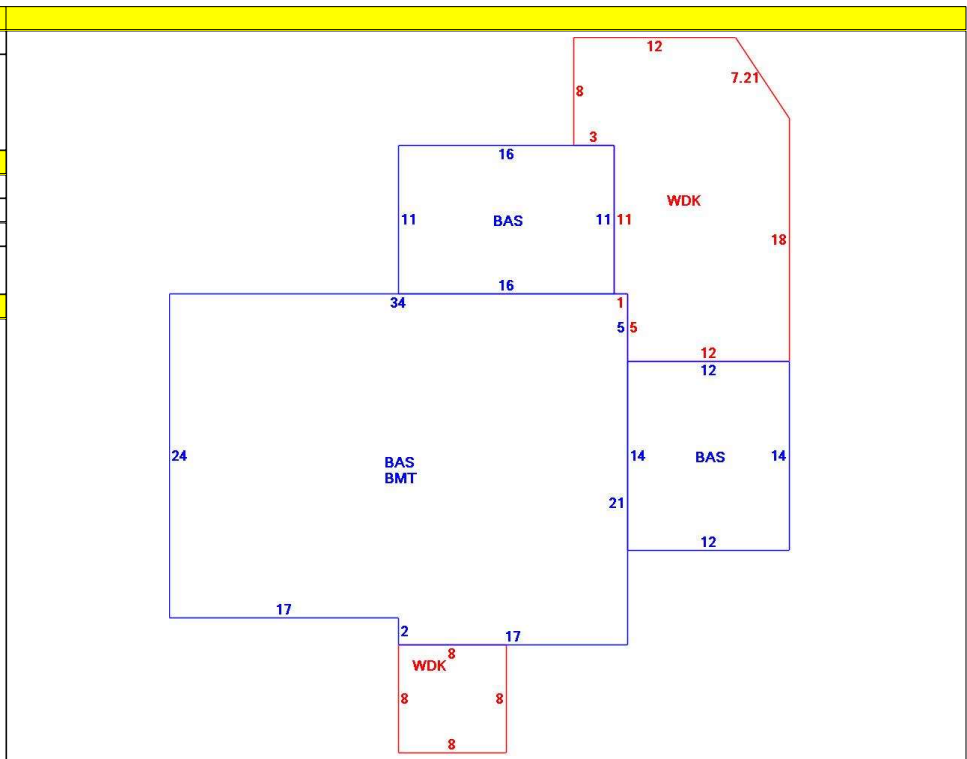

OB - OUTBUILDING & YARD ITEMS(L) / XF - BUILDING EXTRA FEATURES(B)										
Code	Description	L/B	Units	Unit Price	Yr Blt	Cond. Cd	% Gd	Grade	Grade Adj.	Appr. Value
WDC	Wood Decking	L	383	20.00	1997		56		0.00	4,200
BMT	Basement-Unfi	B	850	26.01	1997		81		0.00	19,200

BUILDING SUB-AREA SUMMARY SECTION						
Code	Description	Living Area	Floor Area	Eff Area	Unit Cost	Undeprec Value
BAS	First Floor	1,194	1,194	1,194	283.30	338,260
BMT	Basement Area	0	850	0	0.00	0
WDK	Wood Deck	0	383	0	0.00	0
Ttl Gross Liv / Lease Area		1,194	2,427	1,194		338,260

