

CURRENT OWNER		TOPO	UTILITIES	STRT / ROAD	LOCATION	CURRENT ASSESSMENT				801 FY2024 BARNSTABLE, MA VISION
CUMMINGS, KYLE J		1 Level	1 All Public	1 Paved		Description	Code	Assessed	Assessed	
295 SUDBURY LANE					RESIDENTL	1010	285,600	285,600		
HYANNIS MA 02601					RES LAND	1010	132,000	132,000		
SUPPLEMENTAL DATA										
Alt Prcl ID Split Zonin BID Parcel ResExpt Q NO APP: #DL 1 LOT 14 #DL 2 GIS ID F_981009_2700589				Plan Ref. Land Ct# 38570-B #SR Life Estate PP STATU Assoc Pid#						
						Total		417,600	417,600	

RECORD OF OWNERSHIP		BK-VOL/PAGE	SALE DATE	Q/U	V/I	SALE PRIC	VC	PREVIOUS ASSESSMENTS (HISTORY)								
CUMMINGS, KYLE J		C226205	0	05-10-2021	U	I	247,400	1A	Year	Code	Assessed	Year	Code	Assessed		
RICHTER, RYAN A & MEREDITH A		C188852	0	06-22-2009	Q	I	195,000	00	2023	1010	249,200	2022	1010	218,500		
EDGAR, BARBARA L TR		C171050	0	10-30-2003	U	I	1	1A		1010	126,700		1010	93,800		
EDGAR, BARBARA L		C165602	0	06-14-2002	U	I	209,400	1A					1010	2,300		
ARCIERI, ANTHONY J		#D73455	0	07-28-1998			0		Total		375,900	Total		312,300	Total	273,400

EXEMPTIONS				OTHER ASSESSMENTS				This signature acknowledges a visit by a Data Collector or Assessor								
Year	Code	Description	Amount	Code	Description	Number	Amount	Comm Int								
2023	N5C	NO RESIDENTIAL EXEMPTION	0.00													
Total			0.00													

ASSESSING NEIGHBORHOOD				APPRAISED VALUE SUMMARY			
Nbhd	Nbhd Name	B	Tracing	Batch			
0104				HYAN			
NOTES				Appraised Bldg. Value (Card)	228,700		
				Appraised Xf (B) Value (Bldg)	54,600		
				Appraised Ob (B) Value (Bldg)	2,300		
				Appraised Land Value (Bldg)	132,000		
				Special Land Value	0		
				Total Appraised Parcel Value	417,600		
				Valuation Method	C		
				Total Appraised Parcel Value	417,600		

BUILDING PERMIT RECORD								VISIT / CHANGE HISTORY							
Permit Id	Issue Date	Type	Description	Amount	Insp Date	% Comp	Date Comp	Comments	Date	Id	Type	Is	Cd	Purpost/Result	
EXPR-22-5	04-11-2022	835	Sid/Wind/Roof/	19,500		100		Install 10 windows - no structur AIR SEAL-INSULATE	03-06-2023	AG	22		22	Change of Address	
201105467	10-03-2011	IN	Insulation	3,700		100			02-04-2022	BM	03		16	In Office Review	
									04-23-2020	WD			FR	Field Review	
									11-28-2017	SR	02		03	Cycl Insp Comp	
									01-25-2013	GC	03		16	In Office Review	
									01-14-2013	TR	03		16	In Office Review	
									01-26-2010	TR	22		22	Change of Address	

LAND LINE VALUATION SECTION																	
B	Use Code	Description	Zone	LA	Land Units	Unit Price	Size Adj	AC Disc	Site Index	Cond.	Nbhd.	Nbhd. Adj	Notes	Location Adjustmen	Adj Unit P	Land Value	
1	1010	Single Fam M-0	RB	4	0.230	AC	176,344.00	3.61599	1.0000	5	1.00	0104	0.900		1.0000	573,893.9	132,000
Total Card Land Units					0.23	AC	Parcel Total Land Area					0.23	Total Land Value			132,000	

CONSTRUCTION DETAIL			CONSTRUCTION DETAIL (CONTINUED)		
Element	Cd	Description	Element	Cd	Description
Style	01	Ranch			
Model	01	Residential			
Grade:	C	Average			
Stories	1	1 Story			
Exterior Wall 1	14	Wood Shingle			
Exterior Wall 2	11	Clapboard			
Roof Structure	03	Gable/Hip			
Roof Cover	03	Asph/F Gls/Cmp			
Interior Wall 1	05	Drywall			
Interior Wall 2					
Interior Floor 1	14	Carpet			
Interior Floor 2					
Heat Fuel	03	Gas			
Heat Type	04	Hot Air			
AC Type	01	None			
Bedrooms	02	2 Bedrooms			
Full Baths	1				
Half Baths	1				
Extra Fixtures					
Total Rooms	4	4 Rooms			
Bath Style					
Kitchen Style					
Occupancy					
Usrflid 105					
Accessory Apt					
Foundation Alt	01	Poured Conc.			
Rms Prts					
Bath Split	11	1 Full-1 Half			

CONDO DATA			
Parcel Id		C	Owne 0.0
		B	S
Adjust Type	Code	Description	Factor%
Condo Flr			
Condo Unit			

COST / MARKET VALUATION		
Building Value New		272,232
Year Built		1984
Effective Year Built		1998
Depreciation Code		A
Remodel Rating		
Year Remodeled		
Depreciation %		16
Functional Obsol		0
External Obsol		0
Trend Factor		1
Condition		
Condition %		
Percent Good		84
RCNLD		228,700
Dep % Ovr		
Dep Ovr Comment		
Misc Imp Ovr		
Misc Imp Ovr Comment		
Cost to Cure Ovr		
Cost to Cure Ovr Comment		

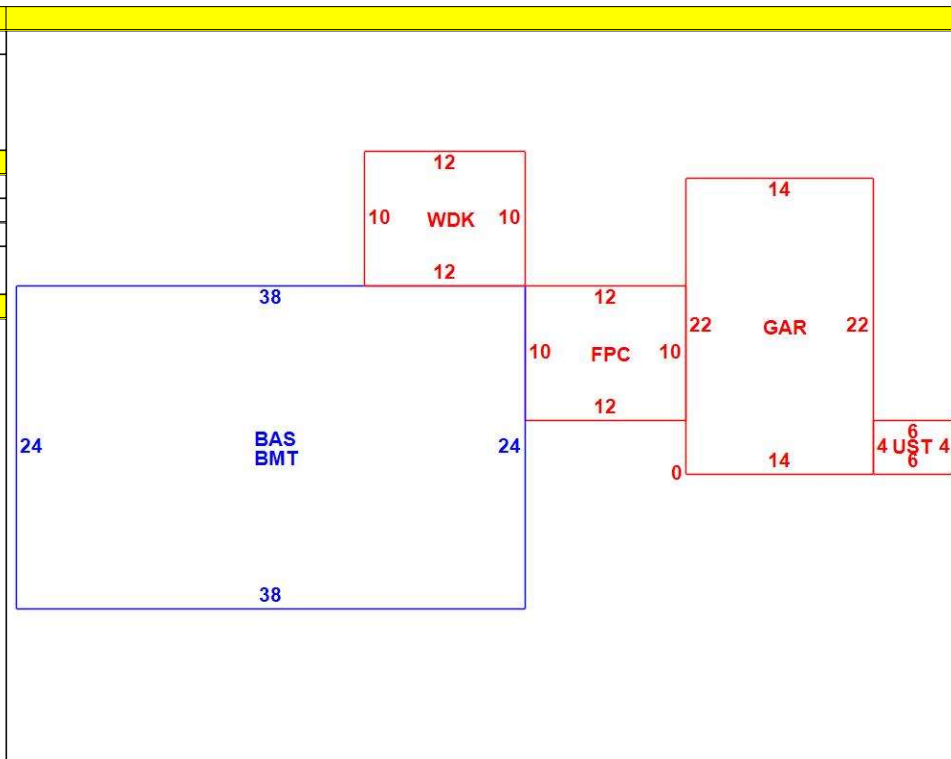

OB - OUTBUILDING & YARD ITEMS(L) / XF - BUILDING EXTRA FEATURES(B)										
Code	Description	L/B	Units	Unit Price	Yr Blt	Cond. Cd	% Gd	Grade	Grade Adj.	Appr. Value
FPL1	Fireplace 1 sto	B	1	5000.00	2000		84		0.00	4,200
BFA	Bsmt Fin-Avg	B	912	17.36	2000		84		0.00	13,300
WDC	Wood Decking	L	120	20.00	1999		60		0.00	2,300
FOPC	Open Prch-roo	B	120	55.00	2000		84		0.00	4,400
GAR	Attached Gara	B	308	40.00	2000		84		0.00	11,400
BMT	Basement-Unfi	B	912	26.01	2000		84		0.00	20,900
UST	Utility Storage-	B	24	17.11	2000		84		0.00	400

BUILDING SUB-AREA SUMMARY SECTION						
Code	Description	Living Area	Floor Area	Eff Area	Unit Cost	Undeprec Value
BAS	First Floor	912	912	912	298.50	272,232
BMT	Basement Area	0	912	0	0.00	0
FPC	Open Porch Conc. Floor	0	120	0	0.00	0
GAR	Attached Garage	0	308	0	0.00	0
UST	Utility Enclosure	0	24	0	0.00	0
WDK	Wood Deck	0	120	0	0.00	0
Ttl Gross Liv / Lease Area		912	2,396	912		272,232

