

| CURRENT OWNER           |  |  |  | TOPO    | UTILITIES    | STRT / ROAD         | LOCATION | CURRENT ASSESSMENT |      |          |          |                                 |
|-------------------------|--|--|--|---------|--------------|---------------------|----------|--------------------|------|----------|----------|---------------------------------|
| CREVIER-SMITH, JULIE A  |  |  |  | 1 Level | 1 All Public | 1 Paved             |          | Description        | Code | Assessed | Assessed | 801<br>FY2024<br>BARNSTABLE, MA |
| 37 WORCESTER LN         |  |  |  |         |              |                     |          | RESIDNTL           | 1010 | 376,300  | 376,300  |                                 |
| HYANNIS MA 02601        |  |  |  |         |              |                     |          | RES LAND           | 1010 | 135,300  | 135,300  |                                 |
| SUPPLEMENTAL DATA       |  |  |  |         |              |                     |          |                    |      |          |          | <b>VISION</b>                   |
| Alt Prcl ID             |  |  |  |         |              | Plan Ref. 383/30-32 |          | Total              |      |          |          |                                 |
| Split Zonin             |  |  |  |         |              | Land Ct#            |          | 511,600            |      |          |          |                                 |
| BID Parcel              |  |  |  |         |              | #SR                 |          |                    |      |          |          |                                 |
| ResExpt Q YES:          |  |  |  |         |              | Life Estate         |          |                    |      |          |          |                                 |
| #DL 1 LOT 18            |  |  |  |         |              | PP STATU            |          |                    |      |          |          |                                 |
| #DL 2                   |  |  |  |         |              | Assoc Pid#          |          |                    |      |          |          |                                 |
| GIS ID F_980796_2701788 |  |  |  |         |              |                     |          |                    |      |          |          |                                 |

| RECORD OF OWNERSHIP              |  |  |  |  |  |  | BK-VOL/PAGE | SALE DATE | Q/U        | V/I | SALE PRIC | VC      | PREVIOUS ASSESSMENTS (HISTORY) |      |       |          |       |      |          |      |       |          |
|----------------------------------|--|--|--|--|--|--|-------------|-----------|------------|-----|-----------|---------|--------------------------------|------|-------|----------|-------|------|----------|------|-------|----------|
| CREVIER-SMITH, JULIE A           |  |  |  |  |  |  | 13757       | 0226      | 04-25-2001 | U   | I         | 120,000 | 1                              | Year | Code  | Assessed | Year  | Code | Assessed | Year | Code  | Assessed |
| MEDEIROS, BRENDA A & EGAN, JAMES |  |  |  |  |  |  | 4889        | 0144      | 01-15-1986 | U   | I         | 1       | A                              | 2023 | 1010  | 323,800  | 2022  | 1010 | 279,500  | 2021 | 1010  | 220,600  |
| MEDEIROS, BRENDA A               |  |  |  |  |  |  | 4432        | 0064      | 02-15-1985 | Q   | I         | 68,950  | U                              |      | 1010  | 129,800  |       | 1010 | 96,100   |      | 1010  | 91,100   |
| FRANCO, NICHOLAS D TR            |  |  |  |  |  |  | 4204        | 0266      | 08-15-1984 | U   | V         | 0       | A                              |      |       |          |       |      |          |      | 1010  | 9,000    |
| Total                            |  |  |  |  |  |  |             |           |            |     |           |         | Total                          |      | Total |          | Total |      | Total    |      | Total |          |

| EXEMPTIONS |      |                       |        | OTHER ASSESSMENTS |             |        |        | This signature acknowledges a visit by a Data Collector or Assessor |  |  |  |  |  |  |  |  |  |  |  |  |
|------------|------|-----------------------|--------|-------------------|-------------|--------|--------|---|--|--|--|--|--|--|--|--|--|--|--|--|
| Year       | Code | Description           | Amount | Code              | Description | Number | Amount | Comm Int  |  |  |  |  |  |  |  |  |  |  |  |  |
| 2010       | 5C   | RESIDENTIAL EXEMPTION | 0.00   |                   |             |        |        |   |  |  |  |  |  |  |  |  |  |  |  |  |
| Total      |      |                       | 0.00   |                   |             |        |        |   |  |  |  |  |  |  |  |  |  |  |  |  |

| ASSESSING NEIGHBORHOOD               |           |  |   | APPRAISED VALUE SUMMARY |  |       |  |  |  |  |  |  |  |  |  |  |  |  |  |
|--------------------------------------|-----------|--|---|-------------------------|--|-------|--|--|--|--|--|--|--|--|--|--|--|--|--|
| Nbhd                                 | Nbhd Name |  | B | Tracing                 |  | Batch |  |  |  |  |  |  |  |  |  |  |  |  |  |
| 0104                                 |           |  |   |                         |  | HYAN  |  |  |  |  |  |  |  |  |  |  |  |  |  |
| NOTES                                |           |  |   |                         |  |       |  |  |  |  |  |  |  |  |  |  |  |  |  |
|                                      |           |  |   |                         |  |       |  |  |  |  |  |  |  |  |  |  |  |  |  |
| Appraised Bldg. Value (Card) 330,000 |           |  |   |                         |  |       |  |  |  |  |  |  |  |  |  |  |  |  |  |
| Appraised Xf (B) Value (Bldg) 37,300 |           |  |   |                         |  |       |  |  |  |  |  |  |  |  |  |  |  |  |  |
| Appraised Ob (B) Value (Bldg) 9,000  |           |  |   |                         |  |       |  |  |  |  |  |  |  |  |  |  |  |  |  |
| Appraised Land Value (Bldg) 135,300  |           |  |   |                         |  |       |  |  |  |  |  |  |  |  |  |  |  |  |  |
| Special Land Value 0                 |           |  |   |                         |  |       |  |  |  |  |  |  |  |  |  |  |  |  |  |
| Total Appraised Parcel Value 511,600 |           |  |   |                         |  |       |  |  |  |  |  |  |  |  |  |  |  |  |  |
| Valuation Method C                   |           |  |   |                         |  |       |  |  |  |  |  |  |  |  |  |  |  |  |  |
| Total Appraised Parcel Value 511,600 |           |  |   |                         |  |       |  |  |  |  |  |  |  |  |  |  |  |  |  |

| BUILDING PERMIT RECORD |            |      |             |        |            |        |           |          |  | VISIT / CHANGE HISTORY |    |      |    |    |                            |
|------------------------|------------|------|-------------|--------|------------|--------|-----------|----------|--|------------------------|----|------|----|----|----------------------------|
| Permit Id              | Issue Date | Type | Description | Amount | Insp Date  | % Comp | Date Comp | Comments |  | Date                   | Id | Type | Is | Cd | Purpost/Result             |
| B27137                 | 10-01-1984 | DW   | Dwelling    | 40,000 | 01-15-1985 | 100    |           | HY       |  | 04-23-2020             | WD |      |    | FR | Field Review               |
|                        |            |      |             |        |            |        |           |          |  | 11-20-2017             | SR | 02   |    | 03 | Cycl Insp Comp             |
|                        |            |      |             |        |            |        |           |          |  | 05-22-2002             | PT | 01   |    | 00 | Meas/Listed-Interior Acces |
|                        |            |      |             |        |            |        |           |          |  | 05-15-1990             | ML | 01   |    | 00 | Meas/Listed-Interior Acces |

| LAND LINE VALUATION SECTION |          |                |      |    |            |            |                        |         |            |       |       |           |                  |                    |            |            |         |
|-----------------------------|----------|----------------|------|----|------------|------------|------------------------|---------|------------|-------|-------|-----------|------------------|--------------------|------------|------------|---------|
| B                           | Use Code | Description    | Zone | LA | Land Units | Unit Price | Size Adj               | AC Disc | Site Index | Cond. | Nbhd. | Nbhd. Adj | Notes            | Location Adjustmen | Adj Unit P | Land Value |         |
| 1                           | 1010     | Single Fam M-0 | RB   | 4  | 0.290      | AC         | 176,344.00             | 2.93869 | 1.0000     | 5     | 1.00  | 0104      | 0.900            |                    | 1.0000     | 466,394.6  | 135,300 |
| Total Card Land Units       |          |                |      |    | 0.29       | AC         | Parcel Total Land Area |         |            |       |       | 0.29      | Total Land Value |                    |            |            | 135,300 |

| CONSTRUCTION DETAIL |    |                | CONSTRUCTION DETAIL (CONTINUED) |    |             |
|---------------------|----|----------------|---------------------------------|----|-------------|
| Element             | Cd | Description    | Element                         | Cd | Description |
| Style               | 01 | Ranch          |                                 |    |             |
| Model               | 01 | Residential    |                                 |    |             |
| Grade:              | C  | Average        |                                 |    |             |
| Stories             | 1  | 1 Story        |                                 |    |             |
| Exterior Wall 1     | 14 | Wood Shingle   |                                 |    |             |
| Exterior Wall 2     | 11 | Clapboard      |                                 |    |             |
| RooF Structure      | 03 | Gable/Hip      |                                 |    |             |
| RooF Cover          | 03 | Asph/F Gls/Cmp |                                 |    |             |
| Interior Wall 1     | 05 | Drywall        |                                 |    |             |
| Interior Wall 2     |    |                |                                 |    |             |
| Interior Floor 1    | 14 | Carpet         |                                 |    |             |
| Interior Floor 2    |    |                |                                 |    |             |
| Heat Fuel           | 03 | Gas            |                                 |    |             |
| Heat Type           | 04 | Hot Air        |                                 |    |             |
| AC Type             | 01 | None           |                                 |    |             |
| Bedrooms            | 02 | 2 Bedrooms     |                                 |    |             |
| Full Baths          | 2  |                |                                 |    |             |
| Half Baths          | 0  |                |                                 |    |             |
| Extra Fixtures      |    |                |                                 |    |             |
| Total Rooms         | 4  | 4 Rooms        |                                 |    |             |
| Bath Style          |    |                |                                 |    |             |
| Kitchen Style       |    |                |                                 |    |             |
| Occupancy           |    |                |                                 |    |             |
| Usrflid 105         |    |                |                                 |    |             |
| Accessory Apt       |    |                |                                 |    |             |
| Foundation Alt      | 01 | Poured Conc.   |                                 |    |             |
| Rms Prts            |    |                |                                 |    |             |
| Bath Split          | 20 | 2 Full-0 Half  |                                 |    |             |

| CONDO DATA  |      |             |          |
|-------------|------|-------------|----------|
| Parcel Id   |      | C           | Owne 0.0 |
| Adjust Type | Code | Description | Factor%  |
| Condo Flr   |      |             |          |
| Condo Unit  |      |             |          |

| COST / MARKET VALUATION  |         |
|--------------------------|---------|
| Building Value New       | 392,847 |
| Year Built               | 1985    |
| Effective Year Built     | 1998    |
| Depreciation Code        | A       |
| Remodel Rating           |         |
| Year Remodeled           |         |
| Depreciation %           | 16      |
| Functional Obsol         | 0       |
| External Obsol           | 0       |
| Trend Factor             | 1       |
| Condition                |         |
| Condition %              |         |
| Percent Good             | 84      |
| RCNLD                    | 330,000 |
| Dep % Ovr                |         |
| Dep Ovr Comment          |         |
| Misc Imp Ovr             |         |
| Misc Imp Ovr Comment     |         |
| Cost to Cure Ovr         |         |
| Cost to Cure Ovr Comment |         |

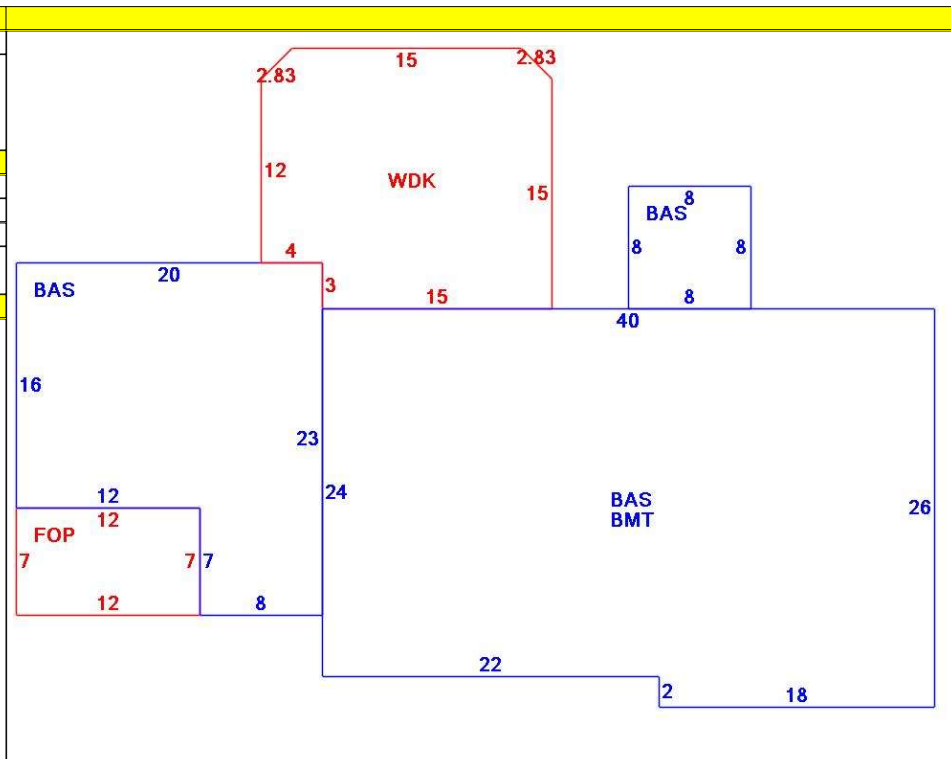

| OB - OUTBUILDING & YARD ITEMS(L) / XF - BUILDING EXTRA FEATURES(B) |               |     |       |            |        |          |      |       |            |             |
|--|---------------|-----|-------|------------|--------|----------|------|-------|------------|-------------|
| Code   | Description   | L/B | Units | Unit Price | Yr Blt | Cond. Cd | % Gd | Grade | Grade Adj. | Appr. Value |
| BFA  | Bsmt Fin-Avg  | B   | 747   | 17.36      | 2000   |          | 84   |       | 0.00       | 10,900      |
| WDC  | Wood Decking  | L   | 307   | 20.00      | 1999   |          | 60   |       | 0.00       | 3,700       |
| BMT  | Basement-Unfi | B   | 996   | 26.01      | 2000   |          | 84   |       | 0.00       | 22,300      |
| SHD2   | Shed w/Elec   | L   | 144   | 26.00      | 2017   |          | 96   |       | 0.00       | 3,600       |
| FOP  | Open Porch-ro | B   | 84    | 55.00      | 2000   |          | 84   |       | 0.00       | 4,100       |
| SHED   | Shed          | L   | 96    | 18.00      | 2017   |          | 96   |       | 0.00       | 1,700       |

| BUILDING SUB-AREA SUMMARY SECTION |               |             |            |          |           |                |
|-----------------------------------|---------------|-------------|------------|----------|-----------|----------------|
| Code                              | Description   | Living Area | Floor Area | Eff Area | Unit Cost | Undeprec Value |
| BAS                               | First Floor   | 1,436       | 1,436      | 1,436    | 273.57    | 392,847        |
| BMT                               | Basement Area | 0           | 996        | 0        | 0.00      | 0              |
| FOP                               | Open Porch    | 0           | 84         | 0        | 0.00      | 0              |
| WDK                               | Wood Deck     | 0           | 307        | 0        | 0.00      | 0              |
| Ttl Gross Liv / Lease Area        |               | 1,436       | 2,823      | 1,436    |           | 392,847        |

