

CURRENT OWNER		TOPO	UTILITIES	STRT / ROAD	LOCATION	CURRENT ASSESSMENT			
FONESI, LEONEL MARTINS 193 FAWCETT LANE HYANNIS MA 02601		1 Level	6 Septic	1 Paved		Description	Code	Assessed	Assessed
			4 Gas			RESIDENTL	1010	401,900	401,900
			2 Public Water			RES LAND	1010	132,000	132,000
SUPPLEMENTAL DATA									
Alt Prcl ID Split Zonin BID Parcel ResExpt Q NO APP: #DL 1 LOT 58 #DL 2			Plan Ref. Land Ct# 22825-P #SR Life Estate PP STATU						
GIS ID F_981991_2701018			Assoc Pid#			Total 533,900 533,900			

801
 FY2024
 BARNSTABLE, MA

VISION

RECORD OF OWNERSHIP		BK-VOL/PAGE	SALE DATE	Q/U	V/I	SALE PRIC	VC	PREVIOUS ASSESSMENTS (HISTORY)					
FONESI, LEONEL MARTINS	C225443	0	02-26-2021	Q	I	400,000	00	Year	Code	Assessed	Year	Code	Assessed
SCHLAGETER, REGINA R	C170946	0	10-20-2003	Q	I	279,900	00	2023	1010	356,200	2022	1010	298,800
MARSH, HEDDA M	C158803	0	08-25-2000	Q	I	157,000	00		1010	126,700		1010	93,800
ZICKO, BIETRE ESTATE OF	C77071	0	01-18-1979	U		0						1010	15,300
Total								482,900	Total	392,600	Total	346,600	

EXEMPTIONS				OTHER ASSESSMENTS			
Year	Code	Description	Amount	Code	Description	Number	Amount
2023	N5C	NO RESIDENTIAL EXEMPTION	0.00				
Total			0.00				

This signature acknowledges a visit by a Data Collector or Assessor

ASSESSING NEIGHBORHOOD			
Nbhd	Nbhd Name	B	Tracing
0104			Batch HYAN

APPRAISED VALUE SUMMARY	
Appraised Bldg. Value (Card)	361,000
Appraised Xf (B) Value (Bldg)	25,600
Appraised Ob (B) Value (Bldg)	15,300
Appraised Land Value (Bldg)	132,000
Special Land Value	0
Total Appraised Parcel Value	533,900
Valuation Method	C
Total Appraised Parcel Value	533,900

NOTES							

BUILDING PERMIT RECORD								VISIT / CHANGE HISTORY						
Permit Id	Issue Date	Type	Description	Amount	Insp Date	% Comp	Date Comp	Comments	Date	Id	Type	Is	Cd	Purpost/Result
201302886	05-07-2013	IN	Insulation	3,800	06-30-2013	100	06-30-2013	INSULATE-AIR SEAL	04-23-2020	WD			FR	Field Review
200903799	03-22-2010	RE	Remodel	0	11-01-2010	100	06-30-2011	AMNESTY APT IN GAR;1BDR	12-07-2017	SR	02		03	Cycl Insp Comp
200805761	11-06-2008	RE	Remodel	100	01-01-2009	100	06-30-2009		08-12-2014	JR	03		16	In Office Review
									03-11-2011	RB	03		02	Bldg Permit Completed
									11-01-2010	MK	02		52	New Construction
									12-15-2009	DR	03		16	In Office Review
									06-19-2009	NF	03		52	New Construction

LAND LINE VALUATION SECTION																	
B	Use Code	Description	Zone	LA	Land Units	Unit Price	Size Adj	AC Disc	Site Index	Cond.	Nbhd.	Nbhd. Adj	Notes	Location Adjustmen	Adj Unit P	Land Value	
1	1010	Single Fam M-0	RB	4	0.230 AC	176,344.00	3.61599	1.0000	5	1.00	0104	0.900		1.0000	573,893.9	132,000	
Total Card Land Units					0.23 AC	Parcel Total Land Area					0.23	Total Land Value					132,000

CONSTRUCTION DETAIL			CONSTRUCTION DETAIL (CONTINUED)		
Element	Cd	Description	Element	Cd	Description
Style	04	Cape Cod			
Model	01	Residential			
Grade:	C	Average			
Stories	1.75	1 3/4 Stories			
Exterior Wall 1	14	Wood Shingle			
Exterior Wall 2					
Roof Structure	03	Gable/Hip			
Roof Cover	03	Asph/F Gls/Cmp			
Interior Wall 1	05	Drywall			
Interior Wall 2					
Interior Floor 1	12	Hardwood			
Interior Floor 2					
Heat Fuel	03	Gas			
Heat Type	04	Hot Air			
AC Type	01	None			
Bedrooms	04	4 Bedrooms			
Full Baths	3				
Half Baths	0				
Extra Fixtures					
Total Rooms	9				
Bath Style					
Kitchen Style					
Occupancy					
Usrflid 105					
Accessory Apt	Y	Apt here			
Foundation Alt	08	Mixed			
Rms Prts					
Bath Split	30	3 Full-0 Half			

CONDO DATA				
Parcel Id	C	B	S	Owne 0.0
Adjust Type	Code	Description	Factor%	
Condo Flr				
Condo Unit				

COST / MARKET VALUATION	
Building Value New	468,863
Year Built	1967
Effective Year Built	1989
Depreciation Code	A
Remodel Rating	
Year Remodeled	
Depreciation %	23
Functional Obsol	0
External Obsol	0
Trend Factor	1
Condition	
Condition %	
Percent Good	77
RCNLD	361,000
Dep % Ovr	
Dep Ovr Comment	
Misc Imp Ovr	
Misc Imp Ovr Comment	
Cost to Cure Ovr	
Cost to Cure Ovr Comment	

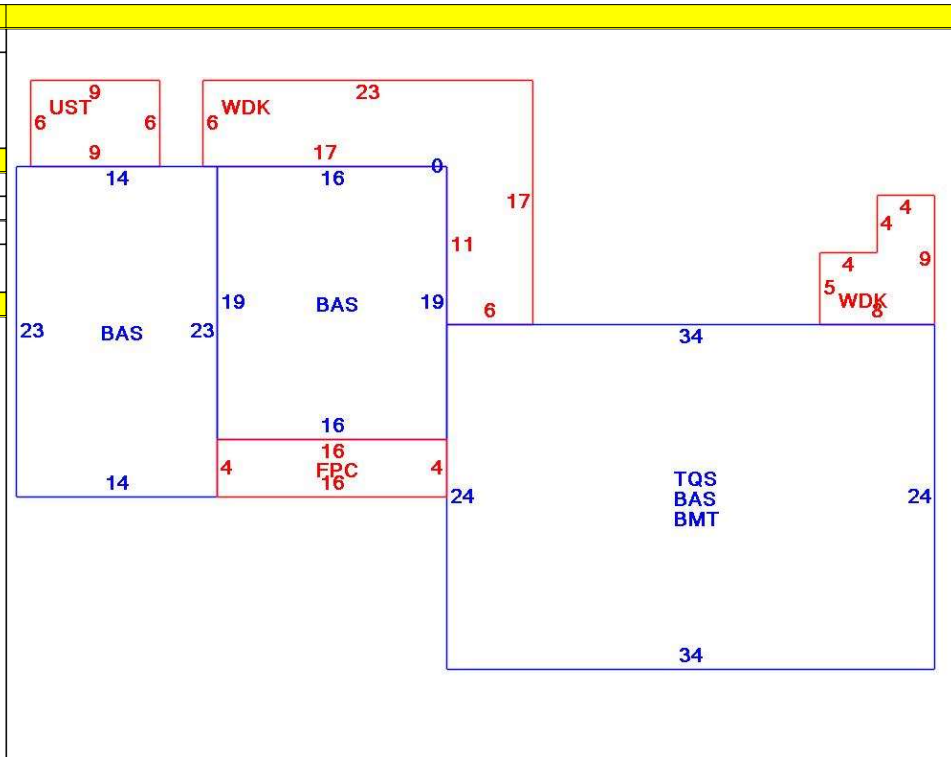

OB - OUTBUILDING & YARD ITEMS(L) / XF - BUILDING EXTRA FEATURES(B)										
Code	Description	L/B	Units	Unit Price	Yr Blt	Cond. Cd	% Gd	Grade	Grade Adj.	Appr. Value
FPL2	Fireplace 1.5 s	B	1	6000.00	1991		77		0.00	4,600
WDC	Wood Decking	L	260	20.00	1995		52		0.00	2,900
FOPC	Open Prch-roo	B	64	55.00	1991		77		0.00	2,600
UST	Utility Storage-	B	54	17.11	1991		77		0.00	700
BMT	Basement-Unfi	B	816	26.01	1991		77		0.00	17,700
GAZ1	Gazebo - Stan	L	1	12887.00	2017		96	C	1.00	12,400

BUILDING SUB-AREA SUMMARY SECTION						
Code	Description	Living Area	Floor Area	Eff Area	Unit Cost	Undeprec Value
BAS	First Floor	1,442	1,442	1,442	237.76	342,850
BMT	Basement Area	0	816	0	0.00	0
FPC	Open Porch Conc. Floor	0	64	0	0.00	0
TQS	Three Quarter Story	530	816	530	154.43	126,013
UST	Utility Enclosure	0	54	0	0.00	0
WDK	Wood Deck	0	260	0	0.00	0
Ttl Gross Liv / Lease Area		1,972	3,452	1,972		468,863

