

CURRENT OWNER		TOPO	UTILITIES	STRT / ROAD	LOCATION	CURRENT ASSESSMENT				801 FY2024 BARNSTABLE, MA VISION		
REIS, JUSTINO S PO BOX 2641 HYANNIS MA 02601	1 Level	6 Septic	1 Paved	9 Rear Location	Description	Code	Assessed	Assessed	RESIDENTL RES LAND		445,100 137,300	445,100 137,300
		4 Gas				1090	445,100	445,100				
		2 Public Water				1090	137,300	137,300				
SUPPLEMENTAL DATA						Total		582,400	582,400			
Alt Prcl ID		Split Zonin		Plan Ref. 116/55								
BID Parcel		ResExpt Q		Land Ct#								
#DL 1 LOT 2				#SR								
#DL 2				Life Estate								
GIS ID F_982200_2702328				PP STATU								
				Assoc Pid#								

RECORD OF OWNERSHIP		BK-VOL/PAGE	SALE DATE	Q/U	V/I	SALE PRIC	VC	PREVIOUS ASSESSMENTS (HISTORY)								
REIS, JUSTINO S	26380	0219	06-01-2012	U	I	106,000	1	Year	Code	Assessed	Year	Code	Assessed	Year	Code	Assessed
GREAT OAK REALTY PARTNERS LP	24715	0104	07-29-2010	U	I	133,000	1L	2023	1090	394,100	2022	1090	324,500	2021	1090	260,400
MCCLAIN, PATRICIA	20645	0156	01-11-2006	U	I	0	1A		1090	131,800		1090	97,600		1090	92,500
PEARSON, ELIZABETH	1765	0187	11-30-1972	U		0		Total		525,900	Total		422,100	Total		365,700

EXEMPTIONS			OTHER ASSESSMENTS					This signature acknowledges a visit by a Data Collector or Assessor										
Year	Code	Description	Amount	Code	Description	Number	Amount	Comm Int										
Total			0.00															

ASSESSING NEIGHBORHOOD				APPRAISED VALUE SUMMARY										
Nbhd	Nbhd Name	B	Tracing	Batch										
0104				HYAN										

NOTES										APPRAISED VALUE SUMMARY									
										Appraised Bldg. Value (Card)						404,700			
										Appraised Xf (B) Value (Bldg)						27,600			
										Appraised Ob (B) Value (Bldg)						12,800			
										Appraised Land Value (Bldg)						137,300			
										Special Land Value						0			
										Total Appraised Parcel Value						582,400			
										Valuation Method						C			
										Total Appraised Parcel Value						582,400			

BUILDING PERMIT RECORD										VISIT / CHANGE HISTORY									
Permit Id	Issue Date	Type	Description	Amount	Insp Date	% Comp	Date Comp	Comments		Date	Id	Type	Is	Cd	Purpost/Result				
16-621	03-21-2016	839	Solar Panel-Re	8,800	08-24-2106	100	06-30-2017	install solar panels on existing		12-09-2022	BM	22		22	Change of Address				
201500097	01-29-2015	DR	Dwelling Rebuil	100,000	01-20-2016	100	06-30-2016	REBUILD SINGLE FAMILY D		04-27-2020	WD			FR	Field Review				
201500096	01-29-2015	DE	Demolish	5,000	06-10-2015	100	06-30-2015	DEMO SINGLE FAMILY		04-11-2017	JR	01		02	Bldg Permit Completed				
201407890	11-18-2014	AD	Addition	60,000	01-20-2016	100	06-30-2016	ADDING 102 SQ FT TO ENLA		01-26-2016	SR	01		02	Bldg Permit Completed				
201308062	11-21-2013	OT	Other	1,000	06-30-2014	100	06-30-2014	RESTORE TO 1 FAM		06-12-2015	SR	01		13	CALLBACK				
										06-24-2013	TP	03		16	In Office Review				
										02-20-2001	SM	01		00	Meas/Listed-Interior Acces				

LAND LINE VALUATION SECTION																			
B	Use Code	Description	Zone	LA	Land Units	Unit Price	Size Adj	AC Disc	Site Index	Cond.	Nbhd.	Nbhd. Adj	Notes			Location Adjustmen	Adj Unit P	Land Value	
1	1090	Multi Hses M-01	RB	4	0.360	AC	176,344.00	2.40337	1.0000	5	1.00	0104	0.900				1.0000	381,432.0	137,300
Total Card Land Units					0.36	AC	Parcel Total Land Area					0.36	Total Land Value					137,300	

CONSTRUCTION DETAIL			CONSTRUCTION DETAIL (CONTINUED)		
Element	Cd	Description	Element	Cd	Description
Style	01	Ranch			
Model	01	Residential			
Grade:	C	Average			
Stories	1	1 Story			
Exterior Wall 1	14	Wood Shingle			
Exterior Wall 2					
Roof Structure	03	Gable/Hip			
Roof Cover	03	Asph/F Gls/Cmp			
Interior Wall 1	05	Drywall			
Interior Wall 2					
Interior Floor 1	12	Hardwood			
Interior Floor 2					
Heat Fuel	03	Gas			
Heat Type	04	Hot Air			
AC Type	03	Central			
Bedrooms	02	2 Bedrooms			
Full Baths	1				
Half Baths	0				
Extra Fixtures					
Total Rooms	4	4 Rooms			
Bath Style					
Kitchen Style					
Occupancy					
Usrflid 105	2				
Accessory Apt					
Foundation Alt	01	Poured Conc.			
Rms Prts					
Bath Split	10	1 Full-0 Half			

CONDO DATA			
Parcel Id		C	Owne 0.0
		B	S
Adjust Type	Code	Description	Factor%
Condo Flr			
Condo Unit			

COST / MARKET VALUATION	
Building Value New	346,552
Year Built	2015
Effective Year Built	2013
Depreciation Code	A
Remodel Rating	
Year Remodeled	
Depreciation %	5
Functional Obsol	0
External Obsol	0
Trend Factor	1
Condition	
Condition %	
Percent Good	95
RCNLD	329,200
Dep % Ovr	
Dep Ovr Comment	
Misc Imp Ovr	
Misc Imp Ovr Comment	
Cost to Cure Ovr	
Cost to Cure Ovr Comment	

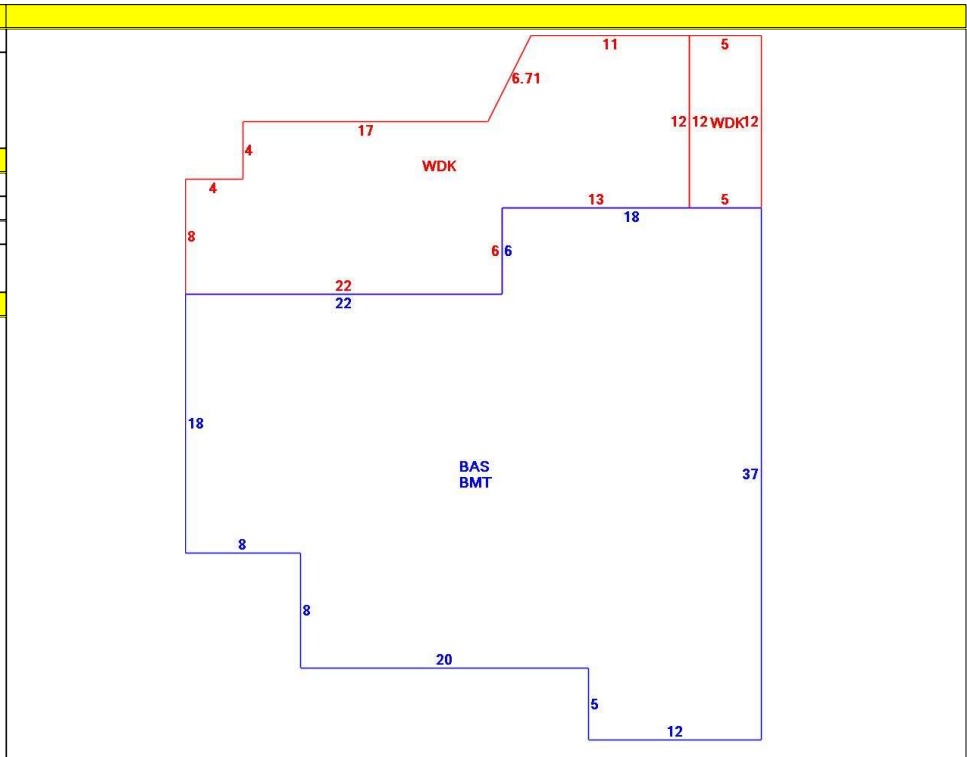

OB - OUTBUILDING & YARD ITEMS(L) / XF - BUILDING EXTRA FEATURES(B)

Code	Description	L/B	Units	Unit Price	Yr Blt	Cond. Cd	% Gd	Grade	Grade Adj.	Appr. Value
WDC	Wood Decking	L	401	20.00	2015		92		0.00	7,100
BMT	Basement-Unfi	B	1,144	26.01	2017		95		0.00	27,600
WDC	Wood Deck w/	L	60	18.00	2015		92		0.00	2,600
SOL1	Solar PV Pane	B	14	860.00	2017		0		0.00	0

BUILDING SUB-AREA SUMMARY SECTION

Code	Description	Living Area	Floor Area	Eff Area	Unit Cost	Undeprec Value
BAS	First Floor	1,144	1,144	1,144	302.93	346,552
BMT	Basement Area	0	1,144	0	0.00	0
WDC	Wood Deck	0	461	0	0.00	0
Ttl Gross Liv / Lease Area		1,144	2,749	1,144		346,552



8.24.2016

CURRENT OWNER		TOPO		UTILITIES		STRT / ROAD		LOCATION		CURRENT ASSESSMENT			
REIS, JUSTINO S PO BOX 2641 HYANNIS MA 02601		1	Level	6	Septic	1	Paved	9	Rear Location	Description	Code	Assessed	Assessed
				4	Gas					RESIDNTL	1090	445,100	445,100
				2	Public Water					RES LAND	1090	137,300	137,300
SUPPLEMENTAL DATA													
Alt Prcl ID Split Zonin BID Parcel ResExpt Q #DL 1 LOT 2 #DL 2 GIS ID F_982200_2702328						Plan Ref. 116/55 Land Ct# #SR Life Estate PP STATU Assoc Pid#				Total 582,400 582,400			

801
 FY2024
 BARNSTABLE, MA

VISION

RECORD OF OWNERSHIP		BK-VOL/PAGE		SALE DATE		Q/U		V/I		SALE PRIC		VC		PREVIOUS ASSESSMENTS (HISTORY)							
REIS, JUSTINO S		26380	0219	06-01-2012		U	I			106,000	1	Year	Code	Assessed	Year	Code	Assessed	Year	Code	Assessed	
GREAT OAK REALTY PARTNERS LP		24715	0104	07-29-2010		U	I			133,000	1L	2023	1090	394,100	2022	1090	324,500	2021	1090	260,400	
MCCLAIN, PATRICIA		20645	0156	01-11-2006		U	I			0	1A		1090	131,800		1090	97,600		1090	92,500	
PEARSON, ELIZABETH		1765	0187	11-30-1972		U				0									1090	12,800	
Total												525,900		Total		422,100		Total		365,700	

EXEMPTIONS				OTHER ASSESSMENTS				This signature acknowledges a visit by a Data Collector or Assessor											
Year	Code	Description	Amount	Code	Description	Number	Amount	Comm Int											
			Total					0.00											

ASSESSING NEIGHBORHOOD				
Nbhd	Nbhd Name	B	Tracing	Batch
0104				HYAN

NOTES												APPRAISED VALUE SUMMARY				
												Appraised Bldg. Value (Card)				404,700
												Appraised Xf (B) Value (Bldg)				27,600
												Appraised Ob (B) Value (Bldg)				12,800
												Appraised Land Value (Bldg)				137,300
												Special Land Value				0
												Total Appraised Parcel Value				582,400
												Valuation Method				C
												Total Appraised Parcel Value				582,400

BUILDING PERMIT RECORD										VISIT / CHANGE HISTORY					
Permit Id	Issue Date	Type	Description	Amount	Insp Date	% Comp	Date Comp	Comments		Date	Id	Type	Is	Cd	Purpost/Result

LAND LINE VALUATION SECTION																		
B	Use Code	Description	Zone	LA	Land Units	Unit Price	Size Adj	AC Disc	Site Index	Cond.	Nbhd.	Nbhd. Adj	Notes	Location Adjustmen	Adj Unit P	Land Value		
2	1090	Multi Hses M-01	RB	4	0 SF	0.00	1.00000	1.0000	5	1.00	0104	0.900		0.0000	0	0		
Total Card Land Units					0.00	SF	Parcel Total Land Area					0.36	Total Land Value					0

CONSTRUCTION DETAIL			CONSTRUCTION DETAIL (CONTINUED)		
Element	Cd	Description	Element	Cd	Description
Style	36	Cottage			
Model	01	Residential			
Grade:	C-	Average Minus			
Stories	1	1 Story			
Exterior Wall 1	14	Wood Shingle			
Exterior Wall 2					
RooF Structure	03	Gable/Hip			
RooF Cover	03	Asph/F Gls/Cmp			
Interior Wall 1	05	Drywall			
Interior Wall 2					
Interior Floor 1	12	Hardwood			
Interior Floor 2					
Heat Fuel	08	Propane			
Heat Type	04	Hot Air			
AC Type	01	None			
Bedrooms	02	2 Bedrooms			
Full Baths	1				
Half Baths	0				
Extra Fixtures					
Total Rooms	4	4 Rooms			
Bath Style					
Kitchen Style					
Occupancy					
UsrflD 105					
Accessory Apt					
Foundation Alt	09	Blk/Pour Ftgs			
Rms Prts					
Bath Split	10	1 Full-0 Half			

CONDO DATA				
Parcel Id		C	Owne	0.0
Adjust Type	Code	Description	Factor%	
Condo Flr				
Condo Unit				

COST / MARKET VALUATION	
Building Value New	109,357
Year Built	1900
Effective Year Built	1979
Depreciation Code	A
Remodel Rating	
Year Remodeled	
Depreciation %	31
Functional Obsol	0
External Obsol	0
Trend Factor	1
Condition	
Condition %	
Percent Good	69
RCNLD	75,500
Dep % Ovr	
Dep Ovr Comment	
Misc Imp Ovr	
Misc Imp Ovr Comment	
Cost to Cure Ovr	
Cost to Cure Ovr Comment	

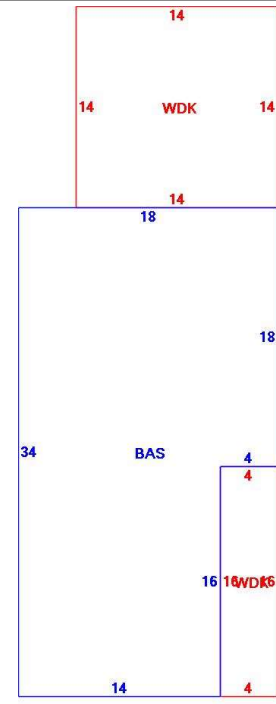

OB - OUTBUILDING & YARD ITEMS(L) / XF - BUILDING EXTRA FEATURES(B)										
Code	Description	L/B	Units	Unit Price	Yr Blt	Cond. Cd	% Gd	Grade	Grade Adj.	Appr. Value
WDC	Wood Decking	L	64	20.00	1986		34		0.00	1,100
WDC	Wood Decking	L	196	20.00	1990		42		0.00	2,000

BUILDING SUB-AREA SUMMARY SECTION						
Code	Description	Living Area	Floor Area	Eff Area	Unit Cost	Undeprec Value
BAS	First Floor	548	548	548	199.56	109,357
WDC	Wood Deck	0	260	0	0.00	0
Ttl Gross Liv / Lease Area		548	808	548		109,357

