

CURRENT OWNER				TOPO	UTILITIES	STRT / ROAD	LOCATION	CURRENT ASSESSMENT				
MCCARTHY, GEORGE M & HARRIET				1 Level	1 All Public	1 Paved		Description	Code	Assessed	Assessed	801 FY2024 BARNSTABLE, MA VISION
59 SEABOARD LN								RESIDNTL	1010	287,400	287,400	
HYANNIS MA 02601								RES LAND	1010	146,700	146,700	
SUPPLEMENTAL DATA												
Alt Prcl ID						Plan Ref.						
Split Zonin						Land Ct# 10614-Q						
BID Parcel						#SR						
ResExpt Q YES:						Life Estate						
#DL 1 LOT 102						PP STATU						
#DL 2						Assoc Pid#						
GIS ID F_979599_2700993								Total		434,100	434,100	

RECORD OF OWNERSHIP				BK-VOL/PAGE	SALE DATE	Q/U	V/I	SALE PRIC	VC	PREVIOUS ASSESSMENTS (HISTORY)									
MCCARTHY, GEORGE M & HARRIET E				C149105	0	06-26-1998	Q	I	95,500	00	Year	Code	Assessed	Year	Code	Assessed			
KELLY, JEAN C				C84453	0	01-30-1981	U		0		2023	1010	247,400	2022	1010	216,200			
												1010	133,300		1010	98,800			
															1010	4,500			
											Total		380,700	Total		315,000	Total		276,600

EXEMPTIONS				OTHER ASSESSMENTS				
Year	Code	Description	Amount	Code	Description	Number	Amount	Comm Int
2010	5C	RESIDENTIAL EXEMPTION	0.00					
Total			0.00					

ASSESSING NEIGHBORHOOD			
Nbhd	Nbhd Name	B	Tracing
0104			Batch HYAN

NOTES			
This signature acknowledges a visit by a Data Collector or Assessor			
APPRAISED VALUE SUMMARY			
Appraised Bldg. Value (Card)			251,400
Appraised Xf (B) Value (Bldg)			31,500
Appraised Ob (B) Value (Bldg)			4,500
Appraised Land Value (Bldg)			146,700
Special Land Value			0
Total Appraised Parcel Value			434,100
Valuation Method			C
Total Appraised Parcel Value			434,100

BUILDING PERMIT RECORD									VISIT / CHANGE HISTORY					
Permit Id	Issue Date	Type	Description	Amount	Insp Date	% Comp	Date Comp	Comments	Date	Id	Type	Is	Cd	Purpost/Result
EXPR-23-11	08-24-2023	835	Sid/Wind/Roof/	25,000		100		STRIP 16.15 SQ. ASPHALT S	04-22-2020	WD			FR	Field Review
EXPR-21-1	07-21-2021	835	Sid/Wind/Roof/	9,068		100		Installing 9 replacement windo	03-22-2019	JD	03		16	In Office Review
201408991	12-29-2014	IN	Insulation	2,700	06-30-2015	100	06-30-2016	WEATHERIZATION/INSULATI	12-13-2018	JB	03		16	In Office Review
									11-29-2017	SR	02		03	Cycl Insp Comp
									05-21-2002	PT	01		00	Meas/Listed-Interior Acces
									07-15-1990	ML	01		00	Meas/Listed-Interior Acces

LAND LINE VALUATION SECTION																	
B	Use Code	Description	Zone	LA	Land Units	Unit Price	Size Adj	AC Disc	Site Index	Cond.	Nbhd.	Nbhd. Adj	Notes	Location Adjustmen	Adj Unit P	Land Value	
1	1010	Single Fam M-0	RB	4	0.230 AC	176,344.00	3.61599	1.0000	5	1.00	0105	1.000		1.0000	637,659.9	146,700	
Total Card Land Units					0.23 AC	Parcel Total Land Area					0.23	Total Land Value					146,700

CONSTRUCTION DETAIL			CONSTRUCTION DETAIL (CONTINUED)		
Element	Cd	Description	Element	Cd	Description
Style	01	Ranch			
Model	01	Residential			
Grade:	C	Average			
Stories	1	1 Story			
Exterior Wall 1	25	Vinyl Siding			
Exterior Wall 2					
RooF Structure	03	Gable/Hip			
RooF Cover	03	Asph/F Gls/Cmp			
Interior Wall 1	05	Drywall			
Interior Wall 2					
Interior Floor 1	12	Hardwood			
Interior Floor 2					
Heat Fuel	03	Gas			
Heat Type	04	Hot Air			
AC Type	03	Central			
Bedrooms	02	2 Bedrooms			
Full Baths	1				
Half Baths	1				
Extra Fixtures					
Total Rooms	4	4 Rooms			
Bath Style					
Kitchen Style					
Occupancy					
Usrflid 105					
Accessory Apt					
Foundation Alt	01	Poured Conc.			
Rms Prts					
Bath Split	11	1 Full-1 Half			

CONDO DATA			
Parcel Id		C	Ownr 0.0
		B	S
Adjust Type	Code	Description	Factor%
Condo Flr			
Condo Unit			

COST / MARKET VALUATION	
Building Value New	306,595
Year Built	1980
Effective Year Built	1996
Depreciation Code	A
Remodel Rating	
Year Remodeled	
Depreciation %	18
Functional Obsol	0
External Obsol	0
Trend Factor	1
Condition	
Condition %	
Percent Good	82
RCNLD	251,400
Dep % Ovr	
Dep Ovr Comment	
Misc Imp Ovr	
Misc Imp Ovr Comment	
Cost to Cure Ovr	
Cost to Cure Ovr Comment	

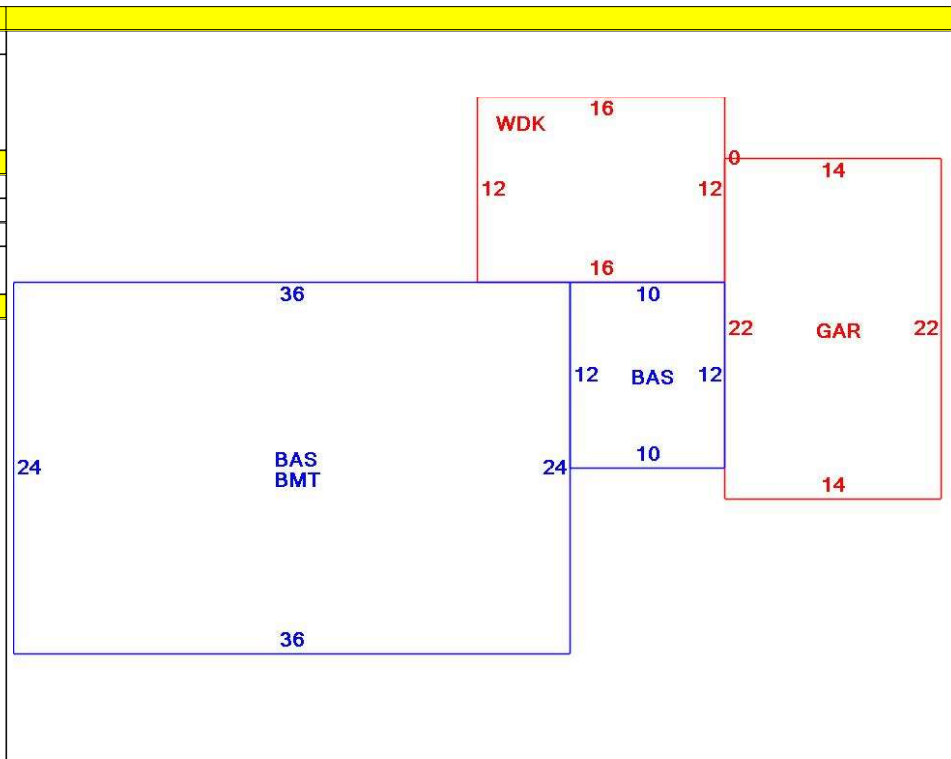

OB - OUTBUILDING & YARD ITEMS(L) / XF - BUILDING EXTRA FEATURES(B)										
Code	Description	L/B	Units	Unit Price	Yr Blt	Cond. Cd	% Gd	Grade	Grade Adj.	Appr. Value
GAR	Attached Gara	B	308	40.00	1998		82		0.00	11,100
BMT	Basement-Unfi	B	864	26.01	1998		82		0.00	19,700
BRR	Bsmt Rec Rm-	B	100	8.05	1998		82		0.00	700
WDC	Wood Decking	L	192	20.00	2017		96		0.00	4,500

BUILDING SUB-AREA SUMMARY SECTION						
Code	Description	Living Area	Floor Area	Eff Area	Unit Cost	Undeprec Value
BAS	First Floor	984	984	984	311.58	306,595
BMT	Basement Area	0	864	0	0.00	0
GAR	Attached Garage	0	308	0	0.00	0
WDC	Wood Deck	0	192	0	0.00	0
Ttl Gross Liv / Lease Area		984	2,348	984		306,595

