

CURRENT OWNER		TOPO	UTILITIES	STRT / ROAD	LOCATION	CURRENT ASSESSMENT				
LAKE, PATRICIA						Description	Code	Assessed	Assessed	801 FY2024 BARNSTABLE, MA
720 PITCHER'S WAY - UNIT 1A		<b>SUPPLEMENTAL DATA</b>				RESIDNTL	1020	239,900	239,900	
HYANNIS	MA 02601	Alt Prcl ID Split Zonin BID Parcel ResExpt Q #DL 1 #DL 2 GIS ID	YES: UNIT 1 BLDG A	Plan Ref. 447/55-56 Land Ct# #SR Life Estate PP STATU Assoc Pid#				Total	239,900	

**VISION**

RECORD OF OWNERSHIP		BK-VOL/PAGE	SALE DATE	Q/U	V/I	SALE PRICE	VC	PREVIOUS ASSESSMENTS (HISTORY)								
LAKE, PATRICIA		27358 0341	05-08-2013	U	I	0	1	Year	Code	Assessed	Year	Code	Assessed	Year	Code	Assessed
LAKE, HOWARD & PATRICIA		14169 0307	08-24-2001	Q	I	130,000	00	2023	1020	228,900	2022	1020	174,500	2021	1020	150,100
JUST, JENNIFER L		12730 0001	12-17-1999	Q	I	78,000	00								1020	3,100
TOUMPAS, NICHOLAS A & LINDA R		12061 0307	02-12-1999	Q	I	68,000	00									
GEMME, GAIL A		6237 0145	05-15-1988	Q	I	75,000	00									
								Total		228,900	Total		174,500	Total		153,200

EXEMPTIONS				OTHER ASSESSMENTS				This signature acknowledges a visit by a Data Collector or Assessor									
Year	Code	Description	Amount	Code	Description	Number	Amount	Comm	Int								
2013	5C	RESIDENTIAL EXEMPTION	0.00														
			Total				0.00										

ASSESSING NEIGHBORHOOD				APPRAISED VALUE SUMMARY									
Nbhd	Nbhd Name	B		Tracing		Batch							
0001						HYAN							
NOTES													
								Appraised Bldg. Value (Card)				229,800	
								Appraised Xf (B) Value (Bldg)				7,000	
								Appraised Ob (B) Value (Bldg)				3,100	
								Appraised Land Value (Bldg)				0	
								Special Land Value				0	
								Total Appraised Parcel Value				239,900	
								Valuation Method				C	
								Total Appraised Parcel Value				239,900	

BUILDING PERMIT RECORD										VISIT / CHANGE HISTORY					
Permit Id	Issue Date	Type	Description	Amount	Insp Date	% Comp	Date Comp	Comments		Date	Id	Type	Is	Cd	Purpost/Result
										04-23-2020	WD			FR	Field Review
										12-11-2018	SR	02		03	Cycl Insp Comp
										09-16-2013	TP	03		16	In Office Review
										05-17-2013	GC	03		16	In Office Review
										05-09-2013	DR	03		16	In Office Review
										05-25-2007	KLP	03		16	In Office Review
										05-16-2000	JG			03	Cycl Insp Comp

LAND LINE VALUATION SECTION																			
B	Use Code	Description	Zone	Dist	Land Type	Land Units	Unit Price	Size Adj	Site Index	Cond.	Nbhd.	Nbhd. Adj	Notes	Location Adjustmen	Adj Unit P	Land Value			
1	102U	Condominium M	RB	4		0 SF	0.00	1.00000	5	1.00	0001	1.000		0.0000	0	0			
Total Card Land Units						0	SF	Parcel Total Land Area						0.00	Total Land Value				0

CONSTRUCTION DETAIL			CONSTRUCTION DETAIL (CONTINUED)		
Element	Cd	Description	Element	Cd	Description
Style	55	Condominium			
Model	05	Res Condo			
Bedrm Func	C	Average			
Stories	1	1 Story			
Occupancy	0				
Interior Wall 1	05	Drywall			
Interior Wall 2					
Interior Floor 1	14	Carpet			
Interior Floor 2					
Heat Fuel	04	Electric			
Heat Type	07	Elec Baseboard			
AC Type	01	None			
Bedrooms	02	2 Bedrooms			
Full Baths	1	1 Full			
Half Baths	0				
Extra Fixtures					
Total Rooms	4	4 Rooms			
Bath Style					
Kitchen Style					
Master Deed L	1004				
Bath Split	10	1 Full-0 Half			
Foundation	08	Mixed			
AC Type Alt					
Sewer Occupan					
<b>CONDO DATA</b>					
Parcel Id	104288	C 0760	Owne	1.5	
	SEA MEADOW VIL	B 1	S 1		
Adjust Type	Code	Description	Factor%		
Condo Flr	1FE	FIRST FL END	100		
Condo Unit	MKT0	MKT0	100		
<b>COST / MARKET VALUATION</b>					
Building Value New		261,168			
Year Built		1988			
Effective Year Built		2003			
Depreciation Code		A			
Remodel Rating					
Year Remodeled		12			
Depreciation %		0			
Functional Obsol		0			
External Obsol		0			
Trend Factor		1			
Condition					
Condition %		88			
Percent Good		229,800			
Cns Sect Rcnd					
Dep % Ovr					
Dep Ovr Comment					
Misc Imp Ovr					
Misc Imp Ovr Comment					
Cost to Cure Ovr					
Cost to Cure Ovr Comment					

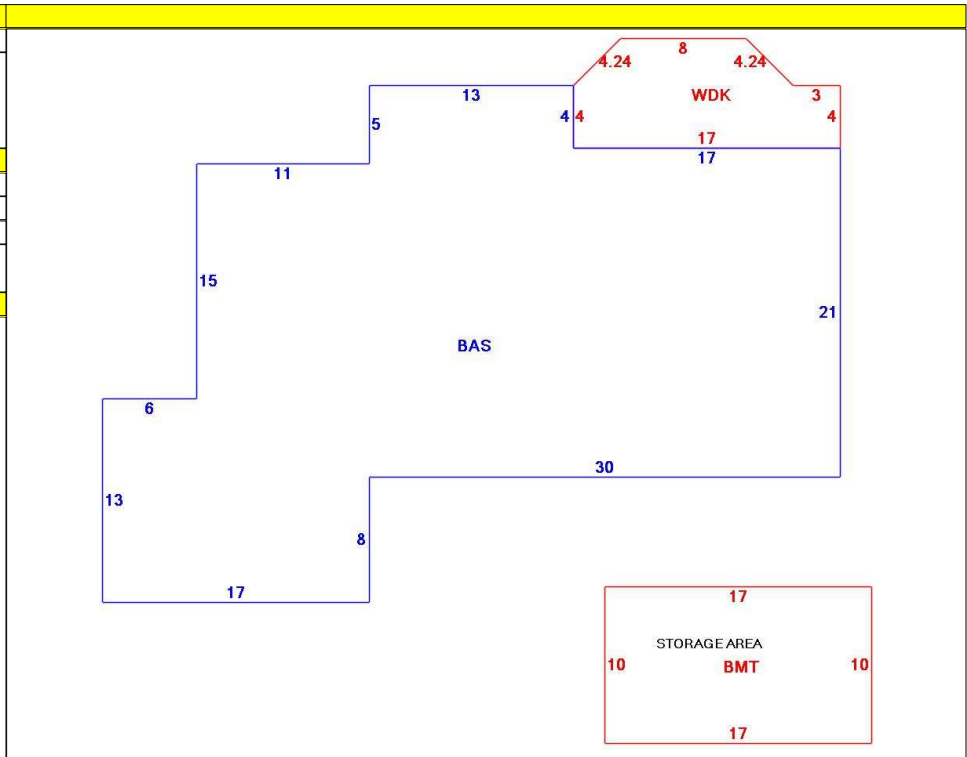

OB - OUTBUILDING & YARD ITEMS(L) / XF - BUILDING EXTRA FEATURES(B)										
Code	Description	L/B	Units	Unit Price	Yr Blt	Cond. Cd	% Gd	Grade	Grade Adj.	Appr. Value
BMT	Basement-Unfi	B	170	26.01	2005		88		0.00	7,000
WDC	Wood Deck w/	L	101	18.00	2018		98		0.00	3,100

BUILDING SUB-AREA SUMMARY SECTION						
Code	Description	Living Area	Floor Area	Eff Area	Unit Cost	Undeprec Value
BAS	First Floor	1,068	1,068	1,068	244.54	261,168
BMT	Basement Area	0	170	0	0.00	0
WDC	Wood Deck	0	101	0	0.00	0
Ttl Gross Liv / Lease Area		1,068	1,339	1,068		261,168

