

CURRENT OWNER		TOPO	UTILITIES	STRT / ROAD	LOCATION	CURRENT ASSESSMENT				
NEWTON, MAE L						Description	Code	Assessed	Assessed	801 FY2024 BARNSTABLE, MA
720 PITCHER'S WAY UNIT A3		<b>SUPPLEMENTAL DATA</b>				RESIDNTL	1020	137,800	137,800	
HYANNIS	MA	02601	Alt Prcl ID Split Zonin BID Parcel ResExpt Q #DL 1 #DL 2 GIS ID		Plan Ref. 447/55-56 Land Ct# #SR Life Estate PP STATU Assoc Pid#	Total 137,800 137,800				

**VISION**

RECORD OF OWNERSHIP		BK-VOL/PAGE	SALE DATE	Q/U	V/I	SALE PRICE	VC	PREVIOUS ASSESSMENTS (HISTORY)									
NEWTON, MAE L		32317 0334	09-23-2019	U	I	107,964	1	Year	Code	Assessed	Year	Code	Assessed V	Year	Code	Assessed	
SCHENA, JOSEPH A		31744 0200	12-21-2018	U	I	98,136	1	2023	1020	131,600	2022	1020	100,800	2021	1020	86,200	
ZIELINSKI, DEBORAH A ESTATE OF		31744 0194	06-19-2018	U	I	0	1F								1020	3,100	
ZIELINSKI, DEBORAH A		6236 0014	04-15-1988	Q	I	70,000	U										
SEA MEADOW VILLAGE ASSOC		6232 0003	04-15-1988	U	I		B										
Total								131,600		Total		100,800		Total		89,300	

EXEMPTIONS				OTHER ASSESSMENTS			
Year	Code	Description	Amount	Code	Description	Number	Amount
2021	5C	RESIDENTIAL EXEMPTION	0.00				
Total			0.00				

This signature acknowledges a visit by a Data Collector or Assessor

ASSESSING NEIGHBORHOOD			
Nbhd	Nbhd Name	B	Tracing
0001			Batch HYAN

APPRAISED VALUE SUMMARY	
Appraised Bldg. Value (Card)	129,900
Appraised Xf (B) Value (Bldg)	4,800
Appraised Ob (B) Value (Bldg)	3,100
Appraised Land Value (Bldg)	0
Special Land Value	0
Total Appraised Parcel Value	137,800
Valuation Method	C
Total Appraised Parcel Value	137,800

NOTES							

BUILDING PERMIT RECORD						VISIT / CHANGE HISTORY								
Permit Id	Issue Date	Type	Description	Amount	Insp Date	% Comp	Date Comp	Comments	Date	Id	Type	Is	Cd	Purpost/Result
									07-09-2020	LH	03		22	Change of Address
									07-06-2020	PK	03		16	In Office Review
									04-23-2020	WD			FR	Field Review
									02-13-2019	CK	22		22	Change of Address
									12-11-2018	SR	02		03	Cycl Insp Comp
									09-16-2013	TP	03		16	In Office Review

LAND LINE VALUATION SECTION																		
B	Use Code	Description	Zone	Dist	Land Type	Land Units	Unit Price	Size Adj	Site Index	Cond.	Nbhd.	Nbhd. Adj	Notes	Location Adjustmen	Adj Unit P	Land Value		
1	102U	Condominium M	RB	4		0 SF	0.00	1.00000	5	1.00	0001	1.000		0.0000	0	0		
Total Card Land Units						0 SF	Parcel Total Land Area						0.00	Total Land Value				0

CONSTRUCTION DETAIL			CONSTRUCTION DETAIL (CONTINUED)		
Element	Cd	Description	Element	Cd	Description
Style	55	Condominium			
Model	05	Res Condo			
Bedrm Func	C	Average			
Stories	1	1 Story			
Occupancy	0				
Interior Wall 1	05	Drywall			
Interior Wall 2					
Interior Floor 1	14	Carpet			
Interior Floor 2					
Heat Fuel	04	Electric			
Heat Type	07	Elec Baseboard			
AC Type	01	None			
Bedrooms	01	1 Bedroom			
Full Baths	1	1 Full			
Half Baths	0				
Extra Fixtures					
Total Rooms	3	3 Rooms			
Bath Style					
Kitchen Style					
Master Deed L	835				
Bath Split	10	1 Full-0 Half			
Foundation	08	Mixed			
AC Type Alt					
Sewer Occupan					
CONDO DATA					
Parcel Id	104288	C 0760	Owne	1.2	
	SEA MEADOW VIL	B 1	S 1		
Adjust Type	Code	Description	Factor%		
Condo Flr	1FU	FIRST FLOOR	100		
Condo Unit	MKT0	MKT0	100		
COST / MARKET VALUATION					
Building Value New			216,550		
Year Built			1988		
Effective Year Built			2003		
Depreciation Code			A		
Remodel Rating					
Year Remodeled			12		
Depreciation %			0		
Functional Obsol			0		
External Obsol			0		
Trend Factor			1		
Condition			H		
Condition %			28		
Percent Good			60		
Cns Sect Rcnld			129,900		
Dep % Ovr					
Dep Ovr Comment					
Misc Imp Ovr					
Misc Imp Ovr Comment					
Cost to Cure Ovr					
Cost to Cure Ovr Comment					

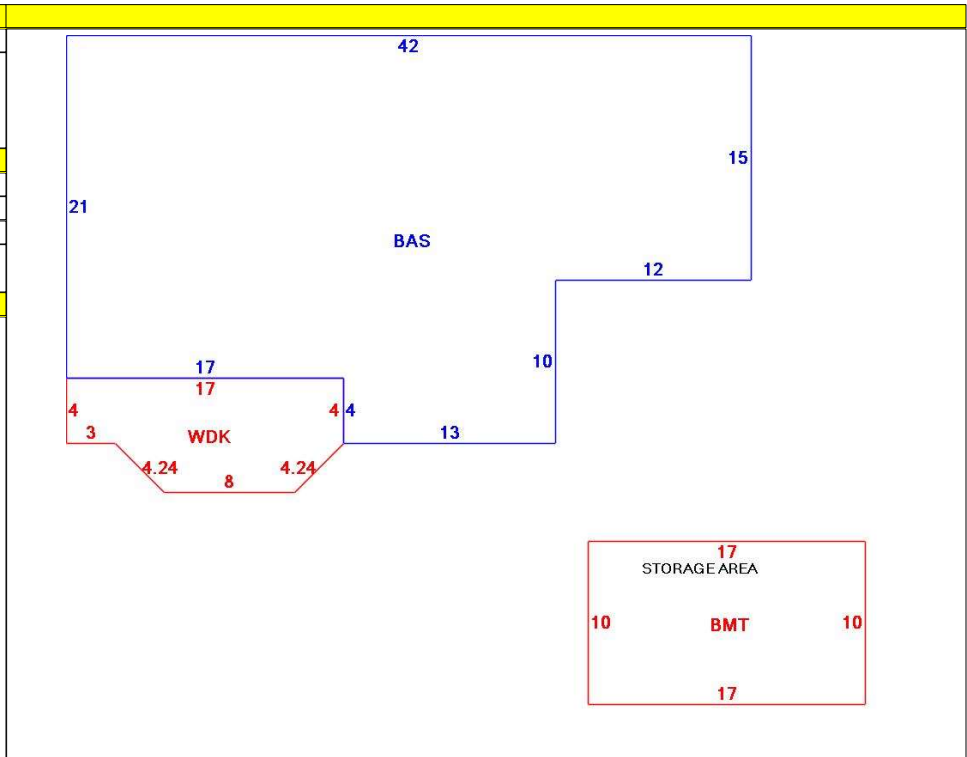

OB - OUTBUILDING & YARD ITEMS(L) / XF - BUILDING EXTRA FEATURES(B)										
Code	Description	L/B	Units	Unit Price	Yr Blt	Cond. Cd	% Gd	Grade	Grade Adj.	Appr. Value
BMT	Basement-Unfi	B	170	26.01	2005		60		0.00	4,800
WDC	Wood Deck w/	L	101	18.00	2018		98		0.00	3,100

BUILDING SUB-AREA SUMMARY SECTION							
Code	Description	Living Area	Floor Area	Eff Area	Unit Cost	Undeprec Value	
BAS	First Floor	862	862	862	251.22	216,550	
BMT	Basement Area	0	170	0	0.00	0	
WDK	Wood Deck	0	101	0	0.00	0	
Ttl Gross Liv / Lease Area		862	1,133	862		216,550	

