

CURRENT OWNER		TOPO	UTILITIES	STRT / ROAD	LOCATION	CURRENT ASSESSMENT				
MOSSAAD, SAMIR A						Description	Code	Assessed	Assessed	801 FY2024 BARNSTABLE, MA
720 PITCHER'S WAY, APT 7A						RESIDNTL	1020	291,100	291,100	
HYANNIS MA 02601		SUPPLEMENTAL DATA								
		Alt Prcl ID Split Zonin BID Parcel ResExpt Q #DL 1 #DL 2 GIS ID		Plan Ref. 447/55-56 Land Ct# #SR Life Estate PP STATU Assoc Pid#		Total		291,100	291,100	VISION

RECORD OF OWNERSHIP		BK-VOL/PAGE	SALE DATE	Q/U	V/I	SALE PRICE	VC	PREVIOUS ASSESSMENTS (HISTORY)									
MOSSAAD, SAMIR A		27946	0001	01-21-2014	U	I	1	1J	Year	Code	Assessed	Year	Code	Assessed	Year	Code	Assessed
MOSSAAD, SAMIR A & AWAD, SAMIRA AZIZ		23662	0183	05-01-2009	U	I	1	1A	2023	1020	277,900	2022	1020	212,100	2021	1020	182,700
MOSSAAD, SAMIR A		15410	0173	07-29-2002	Q	I	142,500	00								1020	3,600
DENNIS, JAMES R		13691	0156	04-02-2001	Q	I	125,500	00									
MALLOY, MICHAEL J & MARIBETH		6246	0183	05-15-1988	Q	I	100,000	00	Total		277,900	Total		212,100	Total		186,300

EXEMPTIONS				OTHER ASSESSMENTS				This signature acknowledges a visit by a Data Collector or Assessor										
Year	Code	Description	Amount	Code	Description	Number	Amount	Comm Int										
2010	5C	RESIDENTIAL EXEMPTION	0.00															
Total			0.00															

ASSESSING NEIGHBORHOOD				APPRAISED VALUE SUMMARY													
Nbhd	Nbhd Name		B	Tracing		Batch											
0001						HYAN											
NOTES																	
Total Appraised Parcel Value										291,100							

BUILDING PERMIT RECORD									VISIT / CHANGE HISTORY						
Permit Id	Issue Date	Type	Description	Amount	Insp Date	% Comp	Date Comp	Comments	Date	Id	Type	Is	Cd	Purpost/Result	
201505280	08-18-2015	IN	Insulation	3,100	06-30-2016	100	06-30-2016	INSULATION/WEATHERIZATI	04-23-2020	WD			FR	Field Review	
201104400	08-19-2011	NW	New Windows	3,196		100		7 NW WIND	12-11-2018	SR	02		03	Cycl Insp Comp	
									09-16-2013	TP	03		16	In Office Review	

LAND LINE VALUATION SECTION																			
B	Use Code	Description	Zone	Dist	Land Type	Land Units	Unit Price	Size Adj	Site Index	Cond.	Nbhd.	Nbhd. Adj	Notes	Location Adjustmen	Adj Unit P	Land Value			
1	102U	Condominium M	RB	4		0 SF	0.00	1.00000	5	1.00	0001	1.000		0.0000	0	0			
Total Card Land Units						0	SF	Parcel Total Land Area						0.00	Total Land Value				0

CONSTRUCTION DETAIL			CONSTRUCTION DETAIL (CONTINUED)		
Element	Cd	Description	Element	Cd	Description
Style	55	Condominium			
Model	05	Res Condo			
Bedrm Func	C	Average			
Stories	2	2 Stories			
Occupancy	0				
Interior Wall 1	05	Drywall			
Interior Wall 2					
Interior Floor 1	14	Carpet			
Interior Floor 2					
Heat Fuel	04	Electric			
Heat Type	07	Elec Baseboard			
AC Type	01	None			
Bedrooms	02	2 Bedrooms			
Full Baths	2	2 Full			
Half Baths	0				
Extra Fixtures					
Total Rooms	4	4 Rooms			
Bath Style					
Kitchen Style					
Master Deed L	1312				
Bath Split	20	2 Full-0 Half			
Foundation	08	Mixed			
AC Type Alt					
Sewer Occupan					
CONDO DATA					
Parcel Id	104288	C 0760	Ownr	1.9	
	SEA MEADOW VIL	B 1	S 1		
Adjust Type	Code	Description	Factor%		
Condo Flr	2FU	SECOND FLOOR	100		
Condo Unit	MKT0	MKT0	100		
COST / MARKET VALUATION					
Building Value New			315,595		
Year Built			1988		
Effective Year Built			2003		
Depreciation Code			A		
Remodel Rating					
Year Remodeled					
Depreciation %			12		
Functional Obsol			0		
External Obsol			0		
Trend Factor			1		
Condition					
Condition %					
Percent Good			88		
Cns Sect Rcnd			277,700		
Dep % Ovr					
Dep Ovr Comment					
Misc Imp Ovr					
Misc Imp Ovr Comment					
Cost to Cure Ovr					
Cost to Cure Ovr Comment					

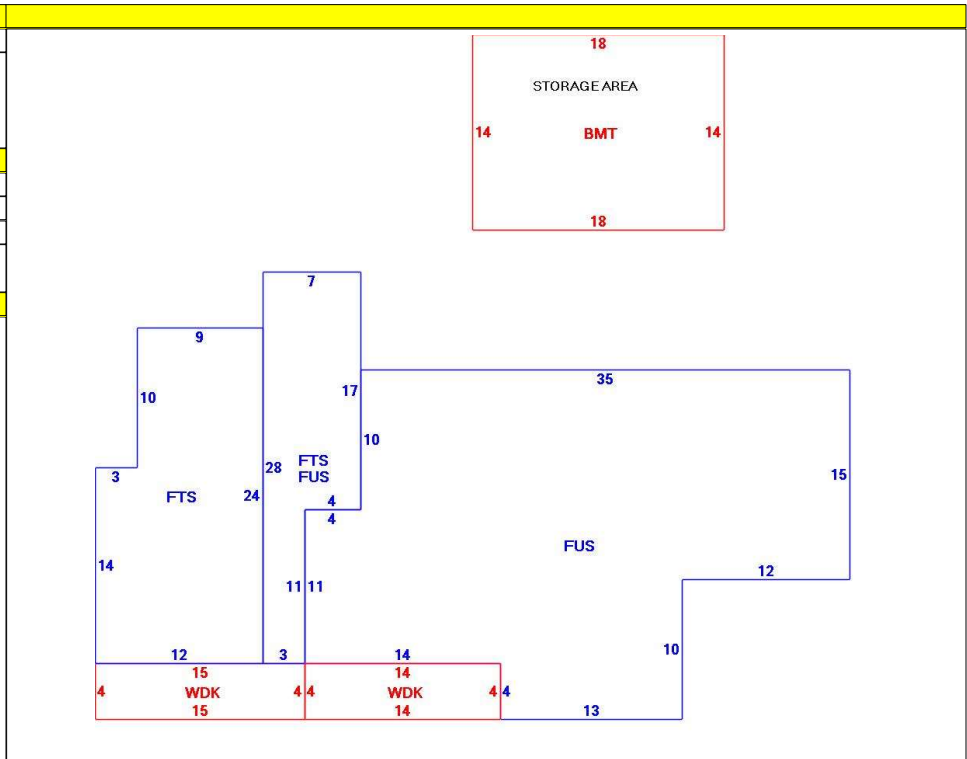

OB - OUTBUILDING & YARD ITEMS(L) / XF - BUILDING EXTRA FEATURES(B)										
Code	Description	L/B	Units	Unit Price	Yr Blt	Cond. Cd	% Gd	Grade	Grade Adj.	Appr. Value
BMT	Basement-Unfi	B	252	26.01	2005		88		0.00	9,800
WDC	Wood Decking	L	116	20.00	2018		98		0.00	3,600

BUILDING SUB-AREA SUMMARY SECTION						
Code	Description	Living Area	Floor Area	Eff Area	Unit Cost	Undeprec Value
BMT	Basement Area	0	252	0	0.00	0
FTS	Finished Third Story	410	410	410	238.91	97,951
FUS	Upper Story	911	911	911	238.91	217,643
WDK	Wood Deck	0	116	0	0.00	0
Ttl Gross Liv / Lease Area		1,321	1,689	1,321		315,594

