

CURRENT OWNER		TOPO	UTILITIES	STRT / ROAD	LOCATION	CURRENT ASSESSMENT				
HUYNH, LIEU T						Description	Code	Assessed	Assessed	801 FY2024 BARNSTABLE, MA
720 PITCHERS WAY, UNIT 8		SUPPLEMENTAL DATA				RESIDNTL	1020	231,200	231,200	
HYANNIS	MA	02601	Alt Prcl ID Split Zonin BID Parcel ResExpt Q YES: #DL 1 UNIT 8 #DL 2 BLDG A GIS ID F_981842_2703782		Plan Ref. 447/55-56 Land Ct# #SR Life Estate PP STATU Assoc Pid#	Total 231,200 231,200				

VISION

RECORD OF OWNERSHIP		BK-VOL/PAGE	SALE DATE	Q/U	V/I	SALE PRICE	VC	PREVIOUS ASSESSMENTS (HISTORY)									
HUYNH, LIEU T		6248	0002	05-15-1988	Q	I	75,000	U	Year	Code	Assessed	Year	Code	Assessed V	Year	Code	Assessed
SEA MEADOW VILLAGE ASSOC		6232	0003	04-15-1988	U	I	1	B	2023	1020	220,700	2022	1020	168,300	2021	1020	144,900
																	2,900
									Total		220,700	Total		168,300	Total		147,800

EXEMPTIONS				OTHER ASSESSMENTS				This signature acknowledges a visit by a Data Collector or Assessor										
Year	Code	Description	Amount	Code	Description	Number	Amount	Comm Int										
2011	5C	RESIDENTIAL EXEMPTION	0.00															
Total			0.00															

ASSESSING NEIGHBORHOOD				APPRAISED VALUE SUMMARY													
Nbhd	Nbhd Name		B	Tracing		Batch											
0001						HYAN											
NOTES																	
										Appraised Bldg. Value (Card)		221,000					
										Appraised Xf (B) Value (Bldg)		7,300					
										Appraised Ob (B) Value (Bldg)		2,900					
										Appraised Land Value (Bldg)		0					
										Special Land Value		0					
										Total Appraised Parcel Value		231,200					
										Valuation Method		C					
										Total Appraised Parcel Value		231,200					

BUILDING PERMIT RECORD									VISIT / CHANGE HISTORY						
Permit Id	Issue Date	Type	Description	Amount	Insp Date	% Comp	Date Comp	Comments	Date	Id	Type	Is	Cd	Purpost/Result	
201502111	04-27-2015	RE	Remodel	15,000	06-30-2015	100	06-30-2015	64 SQ. F.T OF CEILING INSU	04-23-2020	WD			FR	Field Review	
									12-11-2018	SR	02		03	Cycl Insp Comp	
									09-16-2013	TP	03		16	In Office Review	

LAND LINE VALUATION SECTION																			
B	Use Code	Description	Zone	Dist	Land Type	Land Units	Unit Price	Size Adj	Site Index	Cond.	Nbhd.	Nbhd. Adj	Notes	Location Adjustmen	Adj Unit P	Land Value			
1	102U	Condominium M	RB	4		0 SF	0.00	1.00000	5	1.00	0001	1.000		0.0000	0	0			
Total Card Land Units						0	SF	Parcel Total Land Area						0.00	Total Land Value				0

CONSTRUCTION DETAIL			CONSTRUCTION DETAIL (CONTINUED)		
Element	Cd	Description	Element	Cd	Description
Style	55	Condominium			
Model	05	Res Condo			
Bedrm Func	C	Average			
Stories	2	2 Stories			
Occupancy	0				
Interior Wall 1	05	Drywall			
Interior Wall 2					
Interior Floor 1	14	Carpet			
Interior Floor 2					
Heat Fuel	04	Electric			
Heat Type	07	Elec Baseboard			
AC Type	01	None			
Bedrooms	02	2 Bedrooms			
Full Baths	1	1 Full			
Half Baths	0				
Extra Fixtures					
Total Rooms	4	4 Rooms			
Bath Style					
Kitchen Style					
Master Deed L	1008				
Bath Split	10	1 Full-0 Half			
Foundation	08	Mixed			
AC Type Alt					
Sewer Occupan					
CONDO DATA					
Parcel Id	104288	C 0760	Owne	1.6	
	SEA MEADOW VIL	B 1	S 1		
Adjust Type	Code	Description	Factor%		
Condo Flr	2FU	SECOND FLOOR	100		
Condo Unit	MKT0	MKT0	100		
COST / MARKET VALUATION					
Building Value New			251,184		
Year Built			1988		
Effective Year Built			2003		
Depreciation Code			A		
Remodel Rating					
Year Remodeled			12		
Depreciation %			0		
Functional Obsol			0		
External Obsol			0		
Trend Factor			1		
Condition					
Condition %			88		
Percent Good			221,000		
Cns Sect Rcnld					
Dep % Ovr					
Dep Ovr Comment					
Misc Imp Ovr					
Misc Imp Ovr Comment					
Cost to Cure Ovr					
Cost to Cure Ovr Comment					

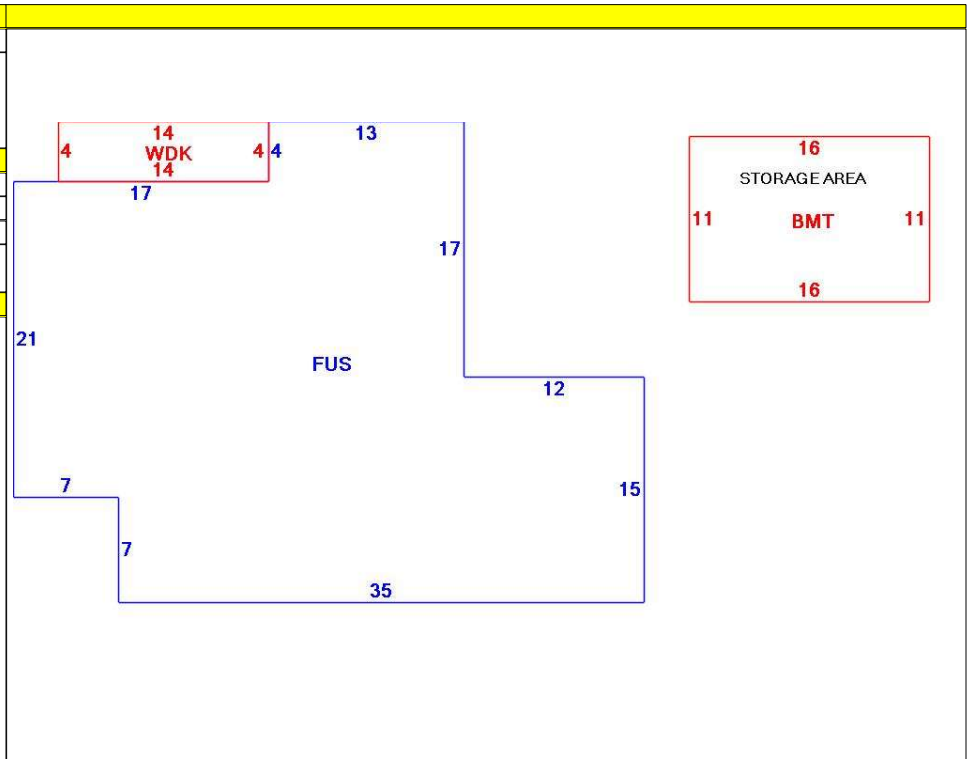

OB - OUTBUILDING & YARD ITEMS(L) / XF - BUILDING EXTRA FEATURES(B)										
Code	Description	L/B	Units	Unit Price	Yr Blt	Cond. Cd	% Gd	Grade	Grade Adj.	Appr. Value
BMT	Basement-Unfi	B	176	26.01	2005		88		0.00	7,300
WDC	Wood Decking	L	56	20.00	2018		98		0.00	2,900

BUILDING SUB-AREA SUMMARY SECTION						
Code	Description	Living Area	Floor Area	Eff Area	Unit Cost	Undeprec Value
BMT	Basement Area	0	176	0	0.00	0
FUS	Upper Story	1,023	1,023	1,023	245.54	251,184
WDK	Wood Deck	0	56	0	0.00	0
Ttl Gross Liv / Lease Area		1,023	1,255	1,023		251,184

